

ROOT

An Object-Oriented
Data Analysis Framework



Users Guide 3.05

June, 2003

Comments to: rootdoc@root.cern.ch

The ROOT Users Guide:

Authors: René Brun/CERN, Fons Rademakers, Suzanne Panacek/FNAL, Ilka Antcheva/CERN, Damir Buskulic/Universite de Savoie/LAPP

Editor: Ilka Antcheva/CERN

Special Thanks to: Jörn Adamczewski/GSI, Marc Hemberger/GSI, Nick West/Oxford, Elaine Lyons, Philippe Canal/FNAL, and Andrey Kubarovsky/FNAL

Preface

In late 1994, we decided to learn and investigate Object Oriented programming and C++ to better judge the suitability of these relatively new techniques for scientific programming. We knew that there is no better way to learn a new programming environment than to use it to write a program that can solve a real problem. After a few weeks, we had our first histogramming package in C++. A few weeks later we had a rewrite of the same package using the, at that time, very new template features of C++. Again, a few weeks later we had another rewrite of the package without templates since we could only compile the version with templates on one single platform using a specific compiler. Finally, after about four months we had a histogramming package that was faster and more efficient than the well-known FORTRAN based HBOOK histogramming package. This gave us enough confidence in the new technologies to decide to continue the development. Thus was born ROOT.

Since its first public release at the end of 1995, ROOT has enjoyed an ever-increasing popularity. Currently it is being used in all major High Energy and Nuclear Physics laboratories around the world to monitor, to store and to analyze data. In the other sciences as well as the medical and financial industries, many people are using ROOT. We estimate the current user base to be around several thousand people.

In 1997, Eric Raymond analyzed in his paper "The Cathedral and the Bazaar" the development method that makes Linux such a success. The essence of that method is: "release early, release often and listen to your customers". This is precisely how ROOT is being developed. Over the last five years, many of our "customers" became co-developers. Here we would like to thank our main co-developers and contributors:

Masaharu Goto who wrote the CINT C++ interpreter. CINT has become an essential part of ROOT. Despite being 8 time zones ahead of us, we often have the feeling he is sitting in the room next door.

Philippe Canal is one of the ROOT main developers. He is responsible for fundamental components of the ROOT system such as the I/O, dictionary, ACLIC and the Tree query mechanism. Philippe is the ROOT support coordinator at FNAL.

Andrei & Mihaela Gheata (Alice collaboration), co-authors of the ROOT geometry classes and Virtual Monte-Carlo.

Olivier Couet, who after a successful development and maintenance of PAW, has joined the ROOT team and is working on the graphics sub-system.

Ilka Antcheva is working on the Graphical User Interface classes. She is also responsible for this latest edition of the Users Guide with a better style, improved index and several new chapters.

Bertrand Bellenot who develops the Win32GDK version of ROOT. Bertrand has also many other contributions like the nice RootShower example.

Valeriy Onuchin is working on the Graphical User Interface under Windows and is developing the Carrot system, a web interface to ROOT and CINT.

Gerri Ganis is working on the authentication procedures to be used by the root daemons and the PROOF system.

Maarten Ballintijn (MIT) is one of the main developers of the PROOF sub-system.

Valeri Fine (now at BNL) who ported ROOT to Windows and who also contributed largely to the 3-D graphics. Valeri is currently working on a version of ROOT using the Qt system as an implementation of the TVirtualX abstract interface.

Victor Perevoztchikov (BNL) is working on key elements of the I/O system, in particular the improved support for STL collections.

Suzanne Panacek who was the author of the first version of this Users Guide. Suzanne has also been very active in preparing tutorials and giving lectures about ROOT.

Nenad Buncic who developed the HTML documentation generation system and integrated the X3D viewer inside ROOT.

Axel Naumann who develops further the THtml class and helps in porting ROOT under Windows (CYGWIN/gcc implementation).

Further we would like to thank all the people mentioned in the \$ROOTSYS/README/CREDITS file for their contributions, and finally, everybody who gave comments, reported bugs and provided fixes.

Happy ROOTing!

Rene Brun & Fons Rademakers

Geneva, June 2003

Table of Contents

Preface	i
Table of Contents	iii
1 Introduction	1
The ROOT Mailing List	1
Contact Information	2
Conventions Used in This Book	2
The Framework	2
What Is a Framework?	3
Why Object-Oriented?	4
Installing ROOT	4
The Organization of the ROOT Framework	4
\$ROOTSYS/bin	5
\$ROOTSYS/lib	6
\$ROOTSYS/tutorials	7
\$ROOTSYS/test	7
\$ROOTSYS/include	8
\$ROOTSYS/<library>	8
How to Find More Information	9
2 Getting Started	11
Start and Quit a ROOT Session	11
Exit ROOT	12
First Example: Using the GUI	12
Second Example: Building a Multi-pad Canvas	15
Printing the Canvas	16
The ROOT Command Line	16
CINT Extensions	16
Helpful Hints for Command Line Typing	17
Multi-line Commands	17
Regular Expression	18
Conventions	18
Coding Conventions	18
Machine Independent Types	19
TObject	19
Global Variables	20
gROOT	20
gFile	20
gDirectory	20
gPad	20
gRandom	21
gEnv	21
History File	21
Environment Setup	21

	The Script Path	22
	Logon and Logoff Scripts	22
	Tracking Memory Leaks.....	22
	Memory Checker	23
	Converting HBOOK/PAW Files.....	23
3	Histograms	25
	The Histogram Classes	25
	Creating Histograms	26
	Fixed or Variable Bin Size.....	27
	Bin Numbering Convention.....	27
	Re-binning.....	27
	Filling Histograms	27
	Automatic Re-binning Option	28
	Random Numbers and Histograms	28
	Adding, Dividing, and Multiplying	29
	Projections	29
	Drawing Histograms.....	29
	Setting the Style.....	30
	Draw Options.....	30
	Statistics Display	32
	Setting Line, Fill, Marker, and Text Attributes.....	32
	Setting Tick Marks on the Axis	32
	Giving Titles to the X, Y and Z Axis.....	33
	The SCATter Plot Option	33
	The ARRow Option.....	33
	The BOX Option.....	33
	The ERRor Bars Options	34
	The Color Option.....	34
	The TEXT Option.....	35
	The CONTOur Options	35
	The LEGO Options.....	36
	The SURFace Options	37
	The BAR Options	37
	Vertical BAR chart.....	37
	Horizontal BAR Chart.....	38
	The Z Option: Display the Color Palette on the Pad.....	39
	Setting the Color Palette	39
	TPaletteAxis	39
	Drawing a Sub-range of a 2-D Histogram (the [cutg] Option)	40
	Drawing Options for 3-D Histograms.....	40
	Superimposing Histograms with Different Scales	40
	Making a Copy of an Histogram.....	41
	Normalizing Histograms.....	42
	Saving/Reading Histograms to/from a File.....	42
	Miscellaneous Operations	42
	Alphanumeric Bin Labels	43
	Histogram Stacks	45
	THStack Example.....	45
	Profile Histograms.....	46
	The TProfile Constructor.....	46
	Example of a TProfile.....	47
	Drawing a Profile without Error Bars.....	48
	Create a Profile from a 2D Histogram	48
	Create a Histogram from a Profile.....	48
	Generating a Profile from a TTree.....	48
	2D Profiles.....	48
	Example of a TProfile2D Histogram	49
4	Graphs	51
	TGraph.....	51

	Creating Graphs.....	51
	Graph Draw Options.....	51
	Continuous Line, Axis and Stars (AC*).....	52
	Bar Graphs (AB).....	52
	Filled Graphs (AF).....	53
	Marker Options.....	53
	Superimposing Two Graphs.....	54
	TGraphErrors.....	55
	TGraphAsymmErrors.....	56
	TMultiGraph.....	57
	Fitting a Graph.....	58
	Setting the Graph's Axis Title.....	58
	Zooming a Graph.....	59
5	Fitting Histograms	61
	The Fit Panel.....	61
	The Fit Method.....	62
	Fit with a Predefined Function.....	62
	Fit with a User-Defined Function.....	63
	Creating a TF1 with a Formula.....	63
	Creating a TF1 with Parameters.....	63
	Creating a TF1 with a User Function.....	64
	Fixing and Setting Bounds for Parameters.....	64
	Fitting Sub Ranges.....	65
	Example: Fitting Multiple Sub Ranges.....	65
	Adding Functions to the List.....	66
	Combining Functions.....	67
	Associated Function.....	69
	Access to the Fit Parameters and Results.....	69
	Associated Errors.....	69
	Fit Statistics.....	69
	The Minimization Package.....	70
	Basic Concepts of Minuit.....	70
	The Transformation of Limited Parameters.....	71
	How to Get the Right Answer from Minuit.....	71
	Reliability of Minuit Error Estimates.....	72
6	A Little C++	75
	Classes, Methods and Constructors.....	75
	Inheritance and Data Encapsulation.....	76
	Creating Objects on the Stack and Heap.....	77
7	CINT the C++ Interpreter	81
	What is CINT?.....	81
	The ROOT Command Line Interface.....	82
	The ROOT Script Processor.....	84
	Un-named Scripts.....	84
	Named Scripts.....	85
	Executing a Script from a Script.....	86
	Resetting the Interpreter Environment.....	86
	A Script Containing a Class Definition.....	88
	Debugging Scripts.....	89
	Inspecting Objects.....	90
	ROOT/CINT Extensions to C++.....	91
	ACLIC - The Automatic Compiler of Libraries for CINT.....	91
	Usage.....	92
	Setting the Include Path.....	93
	Intermediate Steps and Files.....	95
	Moving between Interpreter and Compiler.....	95

8	Object Ownership	97
	Ownership by Current Directory (<i>gDirectory</i>)	97
	Ownership by the Master TROOT Object (<i>gROOT</i>)	98
	The Collection of Specials.....	98
	Access to the Collection Contents	98
	Ownership by Other Objects.....	99
	Ownership by the User	99
	The kCanDelete Bit	99
	The kMustCleanup Bit.....	100
9	Graphics and the Graphical User Interface	101
	Drawing Objects	101
	Interacting with Graphical Objects	101
	Moving, Resizing and Modifying Objects.....	102
	Selecting Objects	103
	Context Menus: the Right Mouse Button	103
	Executing Events when a Cursor Passes on Top of an Object....	105
	Graphical Containers: Canvas and Pad.....	106
	The Global Pad: gPad.....	107
	The Coordinate Systems of a Pad.....	108
	Converting between Coordinates Systems	109
	Dividing a Pad into Sub-pads	109
	Updating the Pad	111
	Making a Pad Transparent.....	111
	Setting the Log Scale is a Pad Attribute	112
	WaitPrimitive method	112
	Locking the Pad.....	113
	Graphical Objects	113
	Lines, Arrows, and Geometrical Objects.....	113
	Text and Latex Mathematical Expressions.....	117
	Mathematical Symbols	118
	Example 1	119
	Example 2.....	119
	Example 3.....	120
	Text in Labels and TPaves.....	121
	Sliders.....	123
	Axis.....	124
	Axis Title.....	124
	Axis Options and Characteristics.....	125
	Setting the Number of Divisions	125
	Zooming the Axis.....	125
	Drawing Axis Independently of Graphs or Histograms	126
	Orientation of Tick Marks on Axis.....	126
	Label Position.....	126
	Label Orientation.....	126
	Labels for Exponents.....	127
	Number of Digits in Labels	127
	Tick Mark Label Position	127
	Label Formatting	127
	Stripping Decimals	128
	Optional Grid.....	128
	Axis Binning Optimization.....	128
	Axis with Time Units	128
	Axis: Example 1	132
	Axis: Example 2	133
	Axis: Example with Time Display	134
	Graphical Objects Attributes.....	135
	Text Attributes.....	135
	Line Attributes.....	138
	Fill Attributes	139
	Color and Color Palettes.....	140

The Graphical Editor	142
Copy/Paste with DrawClone.....	143
Example 1: TCanvas::DrawClonePad	143
Example 2: TObject::DrawClone	143
Copy/Paste Programmatically	144
Legends.....	144
The PostScript Interface.....	146
Special Characters	147
Multiple Pictures in a PostScript File: Case 1	147
Multiple Pictures in a PostScript File: Case 2	148
Create or Modify a Style.....	148
10 Folders and Tasks	151
Folders	151
Why Use Folders?.....	151
How to Use Folders	152
Creating a Folder Hierarchy	152
Posting Data to a Folder (Producer)	153
Reading Data from a Folder (Consumer)	153
Tasks.....	154
Execute and Debug Tasks.....	156
11 Input/Output	157
The Physical Layout of ROOT Files.....	157
The File Header	159
The Top Directory Description.....	159
The Histogram Records.....	159
The Class Description List (StreamerInfo List).....	160
The List of Keys and the List of Free Blocks	161
File Recovery.....	162
The Logical ROOT File: TFile and TKey	162
Viewing the Logical File Contents	164
The Current Directory	165
Objects in Memory and Objects on Disk.....	165
Saving Histograms to Disk.....	167
Histograms and the Current Directory.....	169
Saving Objects to Disk	169
Saving Collections to Disk.....	169
A TFile Object Going Out of Scope.....	170
Retrieving Objects from Disk.....	170
Subdirectories and Navigation.....	171
Streamers	173
Streaming Pointers.....	173
Automatically Generated Streamers	173
Transient Data Members (//!)	174
The Pointer to Objects (//>).....	175
Variable Length Array.....	175
Prevent Splitting (//).....	175
Streamers with Special Additions.....	175
Writing Objects	176
Ignore Object Streamers	177
Streaming a TClonesArray	177
Pointers and References in Persistency.....	178
Streaming C++ Pointers	178
Motivation for the TRef Class	178
Using TRef	178
How Does It Work?.....	179
Action on Demand.....	180
Array of TRef.....	181
Schema Evolution.....	182
The TStreamerInfo Class.....	183

The TStreamerElement Class	183
Example: TH1 StreamerInfo	184
Optimized StreamerInfo	185
Automatic Schema Evolution	185
Manual Schema Evolution	185
Building Class Definitions with the StreamerInfo	186
Example: MakeProject	186
Migrating to ROOT 3	188
Compression and Performance	189
Remotely Access to ROOT Files via a rootd	190
TNetFile URL	190
Remote Authentication	190
A Simple Session	191
The rootd Daemon	191
Starting rootd via inetd	192
Command Line Arguments for rootd	192
Reading ROOT Files via Apache Web Server	192
Using the General Open() Function of TFile	193

12 Trees 195

Why Should You Use a Tree?	195
A Simple TTree	196
Show an Entry with TTree::Show	197
Print the Tree Structure with TTree::Print	197
Scan a Variable the Tree with TTree::Scan	197
The Tree Viewer	198
Creating and Saving Trees	200
Creating a Tree from a Folder Hierarchy	200
Autosave	201
Branches	201
Adding a Branch to Hold a List of Variables	201
Adding a TBranch to Hold an Object	202
Setting the Split-level	203
Exempt a Data Member from Splitting	204
Adding a Branch to Hold a TClonesArray	205
Identical Branch Names	205
Adding a Branch with a Folder	205
Adding a Branch with a Collection	205
Examples for Writing and Reading Trees	206
Example 1: A Tree with Simple Variables	207
Writing the Tree	207
Viewing the Tree	208
Reading the Tree	209
Example 2: A Tree with a C Structure	211
Writing the Tree	212
Analysis	214
Example 3: Adding Friends to Trees	216
Adding a Branch to an Existing Tree	216
TTree::AddFriend	216
Example 4: A Tree with an Event Class	219
The Event Class	219
The EventHeader Class	220
The Track Class	220
Writing the Tree	221
Reading the Tree	222
Trees in Analysis	224
Simple Analysis Using TTree::Draw	224
Using Selection with TTree::Draw	225
Using TCut Objects in TTree::Draw	226
Accessing the Histogram in Batch Mode	226
Using Draw Options in TTree::Draw	226
Superimposing Two Histograms	227

	Setting the Range in TTree::Draw	227
	TTree::Draw Examples.....	228
	Creating an Event List	233
	Filling a Histogram.....	235
	Projecting a Histogram	236
	Using TTree::MakeClass	237
	Using TTree::MakeSelector.....	241
	Performance Benchmarks	242
	Impact of Compression on I/O.....	243
	Chains	244
	TChain::AddFriend.....	245
13	Adding a Class	247
	The Role of TObject	247
	Introspection, Reflection and Run Time Type Identification	247
	Collections.....	247
	Input/Output	248
	Paint/Draw.....	248
	GetDrawOption	248
	Clone/DrawClone	248
	Browse.....	248
	SavePrimitive	248
	GetObjectInfo.....	248
	IsFolder.....	248
	Bit Masks and Unique ID	249
	Motivation.....	249
	Template Support	250
	The Default Constructor	251
	rootcint: The CINT Dictionary Generator	252
	Adding a Class with a Shared Library	255
	The LinkDef.h File	255
	Adding a Class with ACLiC	257
14	Collection Classes	259
	Understanding Collections.....	259
	General Characteristics	259
	Determining the Class of Contained Objects	260
	Types of Collections.....	260
	Ordered Collections (Sequences)	260
	Sorted Collection.....	261
	Unordered Collections.....	261
	Iterators: Processing a Collection	261
	Foundation Classes	261
	TCollection.....	261
	TIterator.....	262
	A Collectable Class.....	262
	The TIter Generic Iterator	263
	The TList Collection	265
	Iterating Over a TList	265
	The TObjArray Collection.....	266
	TClonesArray – An Array of Identical Objects	267
	The Idea Behind TClonesArray.....	267
	Template Containers and STL	268
15	Physics Vectors	269
	The Physics Vector Classes	269
	TVector3	269
	Declaration / Access to the components.....	270
	Other Coordinates.....	270
	Arithmetic / Comparison	271
	Related Vectors	271

	Scalar and Vector Products.....	271
	Angle between Two Vectors	271
	Rotation around Axes	271
	Rotation around a Vector.....	271
	Rotation by TRotation	271
	Transformation from Rotated Frame	272
	TRotation	272
	Declaration, Access, Comparisons	272
	Rotation around Axes	272
	Rotation around Arbitrary Axis	273
	Rotation of Local Axes.....	273
	Inverse Rotation.....	273
	Compound Rotations	273
	Rotation of TVector3.....	273
	TLorentzVector.....	274
	Declaration	274
	Access to Components.....	274
	Vector Components in Non-Cartesian Coordinates.....	275
	Arithmetic and Comparison Operators.....	275
	Magnitude/Invariant mass, beta, gamma, scalar product.....	275
	Lorentz Boost	276
	Rotations.....	276
	Miscellaneous.....	277
	TLorentzRotation.....	277
	Declaration	277
	Access to the Matrix Components/Comparisons.....	278
	Transformations of a Lorentz Rotation.....	278
	Transformation of a TLorentzVector.....	279
	Physics Vector Example	279
16	Matrix Elements and Operations	281
17	The ROOT Geometry Package	283
	Architecture	283
	Volumes and Nodes.....	283
	Shapes and Materials	284
	An Interactive Session	285
	Drawing the Geometry	285
	Particle Tracking	285
	Checking the Geometry.....	286
	Saving Geometry in a File	286
18	The Tutorials and Tests	289
	\$ROOTSYS/tutorials	289
	\$ROOTSYS/test	290
	<i>Event</i> – An Example of a ROOT Application	291
	<i>stress</i> - Test and Benchmark.....	294
	<i>guitest</i> – A Graphical User Interface	295
19	Example Analysis	297
	Explanation.....	297
	Script.....	300
20	Networking	305
	Setting-up a Connection.....	305
	Sending Objects over the Network	305
	Closing the Connection.....	306
	A Server with Multiple Sockets.....	307

21	Writing a Graphical User Interface	309
	The ROOT GUI Classes	309
	Widgets and Frames.....	309
	TVirtualX.....	310
	Abstract Graphics Base Class TVirtualX	310
	A Simple Example	310
	A Standalone Version.....	315
	Widgets Overview	317
	TObject.....	317
	TGWidget.....	317
	TGWindow.....	318
	Frames	318
	Layout Management	321
	Event Processing: Signals and Slots	323
	The Widgets in Details	329
	Buttons.....	329
	Menus.....	333
	Toolbar	335
	List Boxes.....	336
	Combo Boxes	338
	Sliders.....	339
	Progress Bars.....	340
	Static Widgets.....	341
	Status Bar	341
	Splitters.....	342
22	Automatic HTML Documentation	345
23	PROOF: Parallel Processing	347
24	Threads	349
	Threads and Processes	349
	Process Properties.....	349
	Thread Properties.....	349
	The Initial Thread	350
	Implementation of Threads in ROOT	350
	Installation	350
	Classes	350
	TThread	350
	TMutex	350
	TCondition.....	350
	TSemaphore.....	351
	TThread for Pedestrians.....	351
	Initialization.....	351
	Coding	351
	Loading.....	351
	Creating	351
	Running	352
	TThread in More Detail	352
	Asynchronous Actions.....	352
	Synchronous Actions: TCondition	352
	Xlib Connections.....	353
	Canceling a TThread	353
	Advanced TThread: Launching a Method in a Thread	355
	Known Problems.....	356
	Glossary	356
	Process.....	356
	Thread.....	356
	Concurrency	357
	Parallelism.....	357
	Reentrant	357

	Thread-specific Data	357
	Synchronization	357
	Critical Section	357
	Mutex	357
	Semaphore	357
	Readers/Writer Lock	358
	Condition Variable	358
	Multithread Safe Levels	358
	Deadlock	358
	Multiprocessor	358
	List of Example Files	359
	Example: mhs3	359
	Example: conditions	359
	Example: TMhs3	359
	Example: CalcPiThread	359
25	Appendix A: Install and Build ROOT	361
	ROOT Copyright and Licensing Agreement:	361
	Installing ROOT	362
	Choosing a Version	362
	Supported Platforms	362
	Installing Precompiled Binaries	362
	Installing the Source	363
	Installing and Building the Source from a Compressed File	363
	More Build Options	363
	Setting the Environment Variables	365
	Documentation to Download	366
	PostScript Documentation	366
	HTML Documentation	366
26	Index	367

1 Introduction

In the mid 1990's, René Brun and Fons Rademakers had many years of experience developing interactive tools and simulation packages. They had lead successful projects such as PAW, PIAF, and GEANT, and they knew the twenty-year-old FORTRAN libraries had reached their limits. Although still very popular, these tools could not scale up to the challenges offered by the Large Hadron Collider, where the data is a few orders of magnitude larger than anything seen before.

At the same time, computer science had made leaps of progress especially in the area of Object Oriented Design, and René and Fons were ready to take advantage of it.

ROOT was developed in the context of the NA49 experiment at CERN. NA49 has generated an impressive amount of data, around 10 Terabytes per run. This rate provided the ideal environment to develop and test the next generation data analysis.

One cannot mention ROOT without mentioning CINT its C++ interpreter. CINT was created by Masa Goto in Japan. It is an independent product, which ROOT is using for the command line and script processor.

ROOT was, and still is, developed in the "Bazaar style", a term from the book "The Cathedral and the Bazaar" by Eric S. Raymond. It means a liberal, informal development style that heavily leverages the diverse and deep talent of the user community. The result is that physicists developed ROOT for themselves; this made it specific, appropriate, useful, and over time refined and very powerful.

When it comes to storing and mining large amount of data, physics plows the way with its Terabytes, but other fields and industry follow close behind as they acquiring more and more data over time, and they are ready to use the true and tested technologies physics has invented. In this way, other fields and industries have found ROOT useful and they have started to use it also.

The development of ROOT is a continuous conversation between users and developers with the line between the two blurring at times and the users becoming co-developers.

In the bazaar view, software is released early and frequently to expose it to thousands of eager co-developers to pound on, report bugs, and contribute possible fixes. More users find more bugs, because more users add different ways of stressing the program. By now, after six years, many, many users have stressed ROOT in many ways, and it is quiet mature. Most likely, you will find the features you are looking for, and if you have found a hole, you are encouraged to participate in the dialog and post your suggestion or even implementation on roottalk, the ROOT mailing list.

The ROOT Mailing List

You can subscribe to roottalk, the ROOT Mailing list by registering at the ROOT web site: <http://root.cern.ch/root/Registration.phtml>

This is a very active list and if you have a question, it is likely that it has been asked, answered, and stored in the archives. Please use the search engine to see if your question has already been answered before sending mail to root talk.

At: <http://root.cern.ch/root/roottalk/AboutRootTalk.html> you can browse the roottalk archives.
You can send your question without subscribing to: roottalk@root.cern.ch

Contact Information

This book was written by several authors. If you would like to contribute a chapter or add to a section, please contact us. This is the first and early release of this book, and there are still many omissions. However, we wanted to follow the ROOT tradition of releasing early and often to get feedback early and catch mistakes. We count on you to send us suggestions on additional topics or on the topics that need more documentation. Please send your comments, corrections, questions, and suggestions to: rootdoc@root.cern.ch

We attempt to give the user insight into the many capabilities of ROOT. The book begins with the elementary functionality and progresses in complexity reaching the specialized topics at the end.

The experienced user looking for special topics may find these chapters useful: Networking, Writing a Graphical User Interface, Threads, and PROOF: Parallel Processing.

Because this book was written by several authors, you may see some inconsistencies and a "change of voice" from one chapter to the next. We felt we could accept this in order to have the expert explain what they know best.

Conventions Used in This Book

We tried to follow a style convention for the sake of clarity. Here are the few styles we used.

To show source code in scripts or source files:

```
{
  cout << " Hello" << endl;
  float x = 3.;
  float y = 5.;
  int    i = 101;
  cout <<" x = "<<x<<" y = "<<y<<" i = "<<i<< endl;
}
```

To show the ROOT command line, we show the ROOT prompt without numbers. In the interactive system, the ROOT prompt has a line number (`root[12]`); for the sake of simplicity we left off the line number.

Bold monospace font indicates the ROOT class names as `TObject`, `TClass`, and text for you to enter at verbatim.

```
root[] TLine l
root[] l.Print()
TLine  X1=0.000000 Y1=0.000000 X2=0.000000 Y2=0.000000
```

Italic bold monospace font indicates a global variable, for example `gDirectory`. We also used the italic font to *highlight the comments* in the code listing.

When a variable term is used, it is shown between angled brackets. In the example below the variable term `<library>` can be replaced with any library in the `$ROOTSYS` directory: `$ROOTSYS/<library>/inc`.

The Framework

ROOT is an object-oriented framework aimed at solving the data analysis challenges of high-energy physics. There are two key words in this definition, object oriented and framework. First, we explain what we mean by a framework and then why it is an object-oriented framework.

What Is a Framework?

Programming inside a framework is a little like living in a city. Plumbing, electricity, telephone, and transportation are services provided by the city. In your house, you have interfaces to the services such as light switches, electrical outlets, and telephones. The details, for example the routing algorithm of the phone switching system, are transparent to you as the user. You do not care; you are only interested in using the phone to communicate with your collaborators to solve your domain specific problems.

Programming outside of a framework may be compared to living in the country. In order to have transportation and water, you will have to build a road and dig a well. To have services like telephone and electricity you will need to route the wires to your home. In addition, you cannot build some things yourself. For example, you cannot build a commercial airport on your patch of land. From a global perspective, it would make no sense for everyone to build their own airport. You see you will be very busy building the infrastructure (or framework) before you can use the phone to communicate with your collaborators and have a drink of water at the same time.

In software engineering, it is much the same way. In a framework the basic utilities and services, such as I/O and graphics, and are provided. In addition, ROOT being a HEP analysis framework, it provides a large selection of HEP specific utilities such as histograms and fitting. The drawback of a framework is that you are constrained to it, as you are constraint to use the routing algorithm provided by your telephone service. You also have to learn the framework interfaces, which in this analogy is the same as learning how to use a telephone.

If you are interested in doing physics, a good HEP framework will save you much work. Below is a list of the more commonly used components of ROOT:

- Command Line Interpreter
- Histograms and Fitting
- Graphic User Interface widgets
- 2D Graphics
- I/O
- Collection Classes
- Script Processor

There are also less commonly used components, these are:

- 3D Graphics
- Parallel Processing (PROOF)
- Run Time Type Identification (RTTI)
- Socket and Network Communication
- Threads

Advantages of Frameworks

The benefits of frameworks can be summarized as follows:

- Less code to write: The programmer should be able to use and reuse the majority of the code. Basic functionality, such as fitting and histogramming are implemented and ready to use and customize.
- More reliable and robust code: Code inherited from a framework has already been tested and integrated with the rest of the framework.
- More consistent and modular code: Code reuse provides consistency and common capabilities between programs, no matter who writes them. Frameworks also make it easier to break programs into smaller pieces.
- More focus on areas of expertise: Users can concentrate on their particular problem domain. They don't have to be experts at writing user interfaces, graphics, or networking to use the frameworks that provide those services.

Why Object-Oriented?

Object-Oriented Programming offers considerable benefits compared to Procedure-Oriented Programming:

- Encapsulation enforces data abstraction and increases opportunity for reuse.
- Sub classing and inheritance make it possible to extend and modify objects.
- Class hierarchies and containment hierarchies provide a flexible mechanism for modeling real-world objects and the relationships among them.
- Complexity is reduced because there is little growth of the global state, the state is contained within each object, rather than scattered through the program in the form of global variables.
- Objects may come and go, but the basic structure of the program remains relatively static, increases opportunity for reuse of design.

Installing ROOT

The installation and building of ROOT is described in Appendix A: Install and Build ROOT. You can download the binaries (7 MB to 11 MB depending on the platform), or the source (about 3.4 MB). ROOT can be compiled by the GNU g++ compiler on most UNIX platforms.

ROOT is currently running on the following platforms:

- Intel x86 Linux (g++, egcs and KAI/KCC)
- Intel Itanium Linux (g++)
- HP HP-UX 10.x (HP CC and aCC, egcs1.2 C++ compilers)
- IBM AIX 4.1 (xlc compiler and egcs1.2)
- Sun Solaris for SPARC (SUN C++ compiler and egcs)
- Sun Solaris for x86 (SUN C++ compiler)
- Sun Solaris for x86 KAI/KCC
- Compaq Alpha OSF1 (egcs1.2 and DEC/CXX)
- Compaq Alpha Linux (egcs1.2)
- SGI Irix (g++ , KAI/KCC and SGI C++ compiler)
- Windows NT and Windows95 (Visual C++ compiler)
- Mac MkLinux and Linux PPC (g++)
- Hitachi HI-UX (egcs)
- LynxOS
- MacOS (CodeWarrior, no graphics)

The Organization of the ROOT Framework

Now we know in abstract terms what the ROOT framework is, let's look at the physical directories and files that come with the installation of ROOT.

You may work on a platform where your system administrator has already installed ROOT. You will need to follow the specific development environment for your setup and you may not have write access to the directories. In any case, you will need an environment variable called `ROOTSYS`, which holds the path of the top directory.

```
> echo $ROOTSYS
/home/root
```

In the `ROOTSYS` directory are examples, executables, tutorials, header files, and if you opted to download the source it is also here. The directories of special interest to us are `bin`, `tutorials`, `lib`, `test`, and `include`. The diagram on the next page shows the contents of these directories.

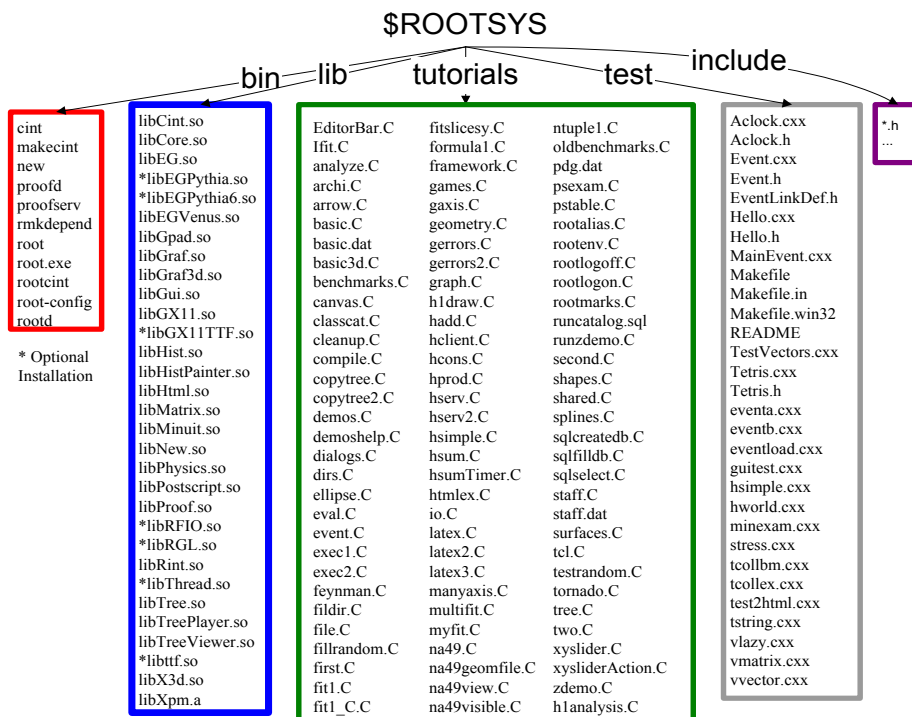

\$ROOTSYS/bin

The `bin` directory contains several executables.

<code>root</code>	shows the ROOT splash screen and calls <code>root.exe</code>
<code>root.exe</code>	is the executable that <code>root</code> calls, if you use a debugger such as <code>gdb</code> , you will need to run <code>root.exe</code> directly
<code>rootcint</code>	is the utility ROOT uses to create a class dictionary for CINT
<code>rmkdepend</code>	is a modified version of <code>makedepend</code> that works for C++ It is used by the ROOT build system
<code>root-config</code>	is a script returning the needed compile flags and libraries for projects that compile and link with ROOT
<code>cint</code>	is the C++ interpreter executable that is independent of ROOT
<code>makecint</code>	is the pure CINT version of <code>rootcint</code> . It is used to generate a dictionary. It is used by some of CINT install scripts to generate dictionaries for external system libraries
<code>proofd</code>	is a small daemon used to authenticate a user of ROOT parallel processing capability (PROOF)
<code>proofserv</code>	is the actual PROOF process, which is started by <code>proofd</code> after a user, has successfully been authenticated
<code>rootd</code>	is the daemon for remote ROOT file access (see TNetFile)

\$ROOTSYS/lib

There are several ways to use ROOT, one way is to run the executable by typing `root` at the system prompt another way is to link with the ROOT libraries and make the ROOT classes available in your own program.

Here is a short description for each library, the ones marked with a * are only installed when the options specified them.

- `libCint.so` is the C++ interpreter (CINT).
- `libCore.so` is the Base classes
- `libEG.so` is the abstract event generator interface classes
- `*libEGPythia5.so` is the Pythia5 event generator interface
- `*libEGPythia6.so` is the Pythia6 event generator interface
- `libEGVenus.so` is the Venus event generator interface
- `libGpad.so` is the pad and canvas classes which depend on low level graphics
- `libGraf.so` is the 2D graphics primitives (can be used independent of `libGpad.so`)
- `libGraf3d.so` is the 3D graphics primitives
- `libGui.so` is the GUI classes (depend on low level graphics)
- `libGX11.so` is the low level graphics interface to the X11 system
- `*libGX11TTF.so` is an add on library to `libGX11.so` providing TrueType fonts
- `libHist.so` is the histogram classes
- `libHistPainter.so` is the histogram painting classes
- `libHtml.so` is the HTML documentation generation system
- `libMatrix.so` is the matrix and vector manipulation
- `libMinuit.so` - The MINUIT fitter
- `libNew.so` is the special global new/delete, provides extra memory checking and interface for shared memory (optional)
- `libPhysics.so` is the physics quantity manipulation classes (`TLorentzVector`, etc.)
- `libPostScript.so` is the PostScript interface
- `libProof.so` is the parallel ROOT Facility classes
- `*libRFIO.so` is the interface to CERN RFIO remote I/O system.
- `*libRGL.so` is the interface to OpenGL.
- `libRint.so` is the interactive interface to ROOT (provides command prompt).
- `*libThread.so` is the Thread classes.
- `libTree.so` is the **TTree** object container system.
- `libTreePlayer.so` is the **TTree** drawing classes.
- `libTreeView.so` is the graphical **TTree** query interface.
- `libX3d.so` is the X3D system used for fast 3D display.

Library Dependencies

The libraries are designed and organized to minimize dependencies, such that you can include just enough code for the task at hand rather than having to include all libraries or one monolithic chunk.

The core library (`libCore.so`) contains the essentials; it needs to be included for all ROOT applications. In the diagram, you see that `libCore` is made up of Base classes, Container classes, Meta information classes, Networking classes, Operating system specific classes, and the ZIP algorithm used for compression of the ROOT files.

The CINT library (`libCint.so`) is also needed in all ROOT applications, but `libCint` can be used independently of `libCore`, in case you only need the C++ interpreter and not ROOT. That is the reason these two are separate.

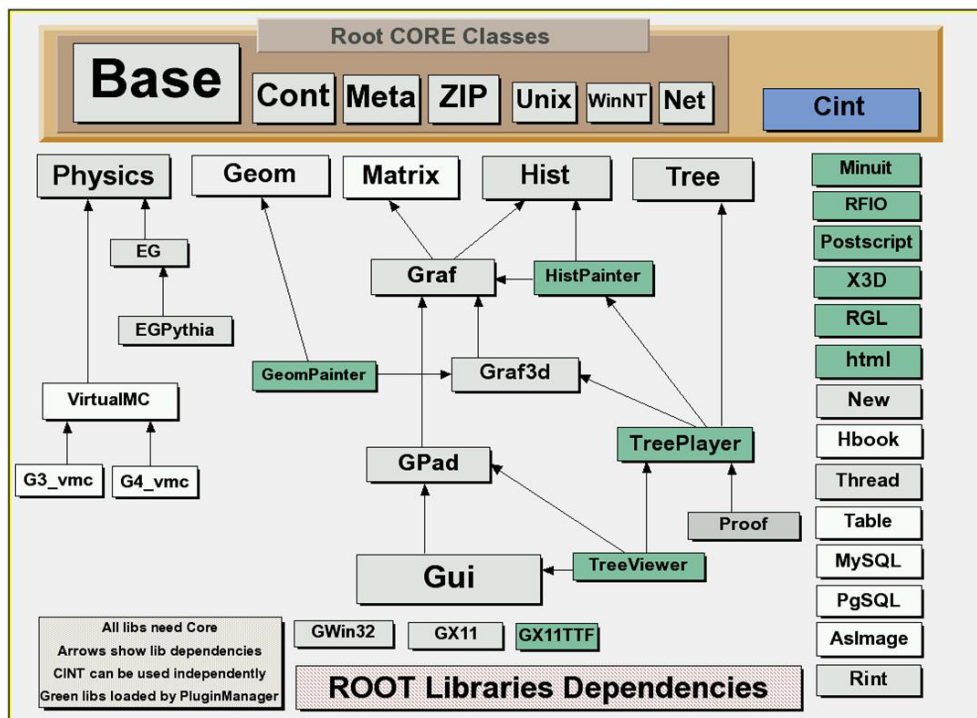

A program referencing only `TObject` only needs `libCore` and `libCint`. This includes the ability to read and write ROOT objects, and there are no dependencies on graphics, or the GUI.

A batch program, one that does not have a graphic display, which creates, fills, and saves histograms and trees, only needs the core (`libCore` and `libCint`), `libHist` and `libTree`. If other libraries are needed, ROOT loads them dynamically. For example if the `TreeViewer` is used, `libTreePlayer` and all the libraries the `TreePlayer` box above has an arrow to, are loaded also. In this case: `GPad`, `Graf3d`, `Graf`, `HistPainter`, `Hist`, and `Tree`. The difference between `libHist` and `libHistPainter` is that the former needs to be explicitly linked and the latter will be loaded automatically at runtime when needed. In the diagram, the dark boxes outside of the core are automatically loaded libraries, and the light colored ones are not automatic. Of course, if one wants to access an automatic library directly, it has to be explicitly linked also. An example of a dynamically linked library is `Minuit`. To create and fill histograms you need to link `libHist`. If the code has a call to fit the histogram, the "Fitter" will check if `Minuit` is already loaded and if not it will dynamically load it.

\$ROOTSYS/tutorials

The tutorials directory contains many example scripts. They assume some basic knowledge of ROOT, and for the new user we recommend reading the chapters: Histograms and Input/Output before trying the examples. The more experienced user can jump to chapter The Tutorials and Tests to find more explicit and specific information about how to build and run the examples.

\$ROOTSYS/test

The test directory contains a set of examples that represent all areas of the framework. When a new release is cut, the examples in this directory are compiled and run to test the new release's backward compatibility.

We see these source files:

- `hsimple.cxx` - Simple test program that creates and saves some histograms
- `MainEvent.cxx` - Simple test program that creates a ROOT Tree object and fills it with some simple structures but also with complete histograms. This program uses the files `Event.cxx`, `EventCint.cxx` and `Event.h`. An example of a procedure to link

this program is in `bind_Event`. Note that the `Makefile` invokes the `rootcint` utility to generate the CINT interface `EventCint.cxx`.

- `Event.cxx` - Implementation for classes `Event` and `Track`
- `minexam.cxx` - Simple test program to test data fitting.
- `tcollex.cxx` - Example usage of the ROOT collection classes
- `tcollbm.cxx` - Benchmarks of ROOT collection classes
- `tstring.cxx` - Example usage of the ROOT string class
- `vmatrix.cxx` - Verification program for the `TMatrix` class
- `vvector.cxx` - Verification program for the `TVector` class
- `vlazy.cxx` - Verification program for lazy matrices.
- `hworld.cxx` - Small program showing basic graphics.
- `guitest.cxx` - Example usage of the ROOT GUI classes
- `Hello.cxx` - Dancing text example
- `Aclock.cxx` - Analog clock (a la X11 `xclock`)
- `Tetris.cxx` - The famous Tetris game (using ROOT basic graphics)
- `stress.cxx` - Important ROOT stress testing program.

The `$ROOTSYS/test` directory is a gold mine of ROOT-wisdom nuggets, and we encourage you to explore and exploit it. However, we recommend that the new user read the chapter '[Getting Started](#)' The chapter '[Tutorials and Tests](#)' has instructions on how to build all the programs and goes over the examples `Event` and `stress`.

\$ROOTSYS/include

The `include` directory contains all header files. It is especially important because the header files contain the class definitions.

\$ROOTSYS/<library>

The directories we explored above are available when downloading the binaries or the source. When downloading the source you also get a directory for each library with the corresponding header and source files. Each library directory contains an `inc` and `src` subdirectory. To see what classes are in a library, you can check the `<library>/inc` directory for the list of class definitions. For example, the physics library contains these class definitions:

```
> ls -m $ROOTSYS/physics/inc
CVS, LinkDef.h, TLorentzRotation.h, TLorentzVector.h, TRotation.h,
TVector2.h, TVector3.h
```

How to Find More Information

The ROOT web site has up to date documentation. The ROOT source code automatically generates this documentation, so each class is explicitly documented on its own web page, which is always up to date with the latest official release of ROOT. The class index web pages can be found at <http://root.cern.ch/root/html/ClassIndex.html>. Each page contains a class description, and an explanation of each method. It shows the class it was derived from and lets you jump to the parent class page by clicking on the class name. If you want more detail, you can even see the source. In addition to this, the site contains tutorials, "How To's", and a list of publications and example applications.

The image displays several screenshots from the ROOT website's documentation:

- TNamed Class Page:** Shows the class `TNamed` derived from `TObject`. It lists methods such as `TNamed()`, `GetName()`, and `SetTitle()`.
- TTree Class Page:** Shows the class `TTree` derived from `TNamed`, `TAttLine`, `TAttFill`, and `TAttMarker`. It lists methods like `GetNameByIndex()` and `MakeIndex()`.
- Class Description:** A detailed text description of the `TTree` class, explaining its structure (header, branches, buffers) and usage.
- Source:** A snippet of C++ code showing the `TTree` constructor, including comments and initialization of member variables like `fScanField`, `fMaxEntryLoop`, and `fMaxVirtualSize`.

Handwritten annotations with arrows identify key elements: "Parent class" points to `TObject` in the `TNamed` page; "Class Description" points to the text description of `TTree`; "Source" points to the C++ code for `TTree`; and "Method" points to the `TTree` constructor code.

2 Getting Started

We begin by showing you how to use ROOT interactively. There are two examples to click through and learn how to use the GUI. We continue by using the command line, and explaining the coding conventions, global variables and the environment setup.

If you have not installed ROOT, you can do so by following the instructions in the appendix, or on the ROOT web site: <http://root.cern.ch/root/Availability.html>

Start and Quit a ROOT Session

To start ROOT you can type `root` at the system prompt. This starts up CINT the ROOT command line C/C++ interpreter and it gives you the ROOT prompt (`root [0]`).

```
% root
*****
*                                     *
*           W E L C O M E  to  R O O T   *
*                                     *
*   Version   3.05/03           25 March 2003 *
*                                     *
*   You are welcome to visit our Web site *
*           http://root.cern.ch           *
*                                     *
*****
FreeType Engine v2.1.3 used to render TrueType fonts.
Compiled for linux with thread support.

CINT/ROOT C/C++ Interpreter version 5.15.80, Mar 17 2003
Type ? for help. Commands must be C++ statements.
Enclose multiple statements between { }.
root [0]
```

It is possible to launch ROOT with some command line options, as shown on the next page:

```
% root -/?
Usage: root [-l] [-b] [-n] [-q] [file1.C ... fileN.C]
Options:
  -b : run in batch mode without graphics
  -n : do not execute logon and logoff macros as
       specified in .rootrc
  -q : exit after processing command line script files
  -l : do not show the image logo (splash screen)
```

`-b`: ROOT session runs in batch mode, without graphics display. This mode is useful in case one does not want to set the `DISPLAY` or cannot do it for some reason.

`-n`: Usually, launching a ROOT session will execute a logon script and quitting will execute a logoff script. This option prevents the execution of these two scripts.

It is also possible to execute a script without entering a ROOT session. One simply adds the name of the script(s) after the ROOT command. Be warned: after finishing the execution of the script, ROOT will normally enter a new session.

-q: It is processing command line script files and exit. Retrieving previous commands and navigating on the Command Line.

For example if you would like to run a script in the background, exit after execution, and redirect the output into a file, use the following syntax:

```
root -b -q myMacro.C > myMacro.log
```

You can build a shared library with ACLiC (see the Chapter on [CINT](#)) and then use the shared library on the command line for a quicker execution (i.e. compiled speed rather than interpreted speed).

```
root -b -q myMacro.so > myMacro.log
```

ROOT has a powerful C/C++ interpreter giving you access to all available ROOT classes, global variables, and functions via a command line. By typing C++ statements at the prompt, you can create objects, call functions, execute scripts, etc. For example:

```
root[] 1+sqrt(9)
(double)4.0000000000000e+00
root[] for (int i = 0; i<4; i++) cout << "Hello" << i << endl
Hello 0
Hello 1
Hello 2
Hello 3
root[] .q
```

Exit ROOT

Type `.q` to quit the command line.

```
root[] .q
```

First Example: Using the GUI

In this example, we show how to use a function object, and change its attributes using the GUI. Again, start ROOT:

```
% root
root[] TF1 f1("func1", "sin(x)/x", 0, 10)
root[] f1.Draw()
```

You should see something like this:

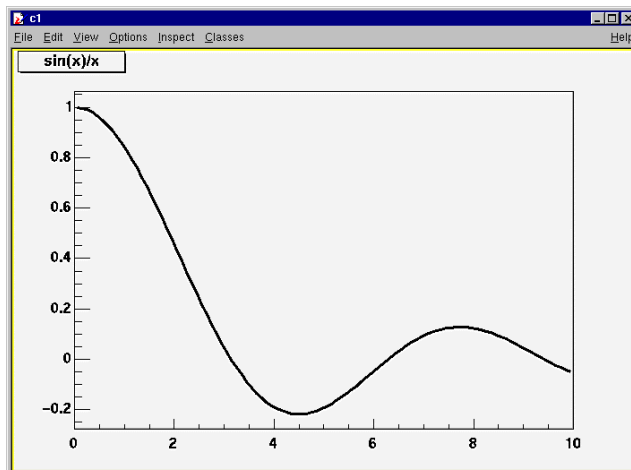

NOTE: The GUI on MS-Windows looks and works a little different from the one on UNIX. We are working on porting the new GUI class to Windows. Once they are available, the GUI will be changed to be identical to the one in UNIX. In this book, we used the UNIX GUI.

Drawing a function is interesting, but it is not unique to a function. Evaluating and calculating the derivative and integral are what one would expect from a function. **TF1**, the function class defines these methods for us.

```
root[] f1.Eval(3)
(Double_t) 4.70400026866224020e-02
root[] f1.Derivative(3)
(Double_t) (-3.45675056671992330e-01)
root[] f1.Integral(0,3)
(Double_t) 1.84865252799946810e+00
root[] f1.Draw
```

Note that by default **TF1::Paint**, the method that draws the function, computes 100 equidistant points to draw it. You can set the number of points to a higher value with the **TF1::SetNpx()** method:

```
root[] f1.SetNpx(2000);
```

Classes, Methods and Constructors

Object oriented programming introduces objects, which have data members and methods.

The line **TF1 f1("func1", "sin(x)/x", 0, 10)** creates an object named **f1** of the class **TF1** that is a one-dimensional function. The type of an object is called a class. The object is called an instance of a class. When a method builds an object, it is called a constructor.

```
TF1 f1("func1", "sin(x)/x", 0, 10)
```

In our constructor, we used $\sin(x)/x$, which is the function to use, and 0 and 10 are the limits. The first parameter, **func1** is the name of the object **f1**. Most objects in ROOT have a name. ROOT maintains a list of objects that can be searched to find any object by its given name (in our example **func1**).

The syntax to call an object's method, or if one prefers, to make an object do something is:

```
object.method_name(parameters)
```

This is the usual way of calling methods in C++. The dot can be replaced by **"->"** if **object** is a pointer. In compiled code, the dot **MUST** be replaced by a **"->"** if **object** is a pointer.

```
object_ptr->method_name(parameters)
```

So now, we understand the two lines of code that allowed us to draw our function. **f1.Draw()** stands for "call the method **Draw** associated with the object **f1** of class **TF1**". We will see the advantages of using objects and classes very soon.

One point, the ROOT framework is an object oriented framework; however this does not prevent the user from calling plain functions. For example, most simple scripts have functions callable by the user.

User interaction

If you have quit the framework, try to draw the function $\sin(x)/x$ again. Now, we can look at some interactive capabilities. Every object in a window (which is called a canvas) is in fact a graphical object in the sense that you can grab it, resize it, and change some characteristics with a mouse click.

For example, bring the cursor over the x-axis. The cursor changes to a hand with a pointing finger when it is over the axis. Now, left click and drag the mouse along the axis to the right. You have a very simple zoom.

When you move the mouse over any object, you can get access to selected methods by pressing the right mouse button and obtaining a context menu. If you try this on the function **TF1**, you will get a menu showing available methods. The other objects on this canvas are the title a **TPaveText**, the x and y-axis, which are **TAxis** objects, the frame a **TFrame**, and the canvas a **TCanvas**. Try clicking on these and observe the context menu with their methods.

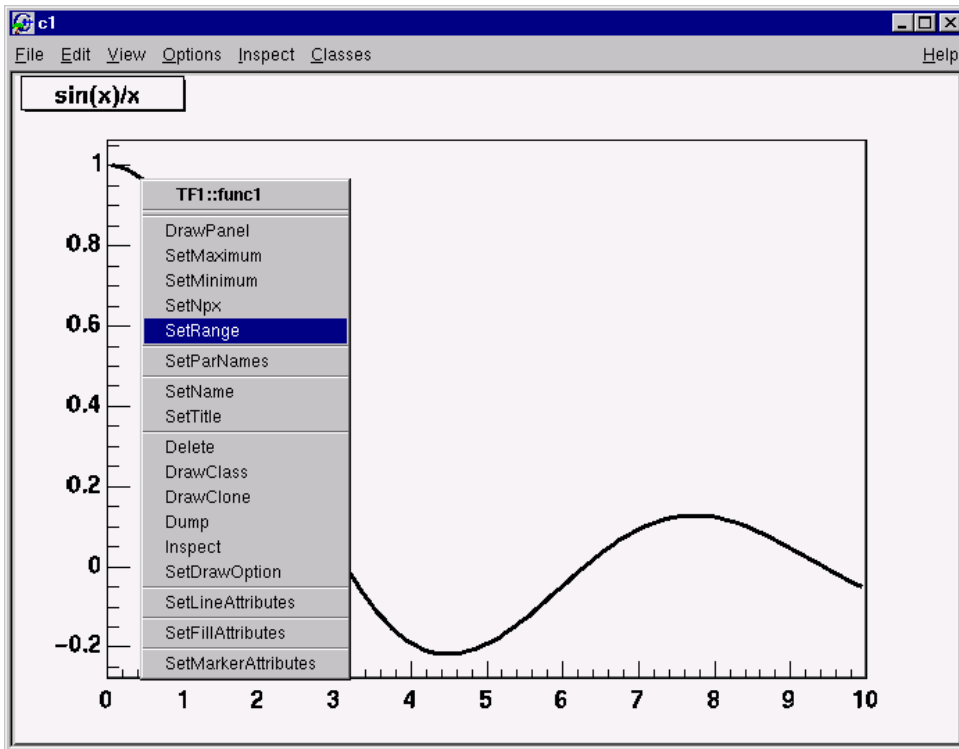

For the function, try for example to select the `SetRange` method and put -10, 10 in the dialog box fields. This is equivalent to executing the member function `f1.SetRange(-10,10)` from the command line prompt, followed by `f1.Draw()`.

Here are some other options you can try. For example, select the `DrawPanel` item of the popup menu. You will see a panel like this:

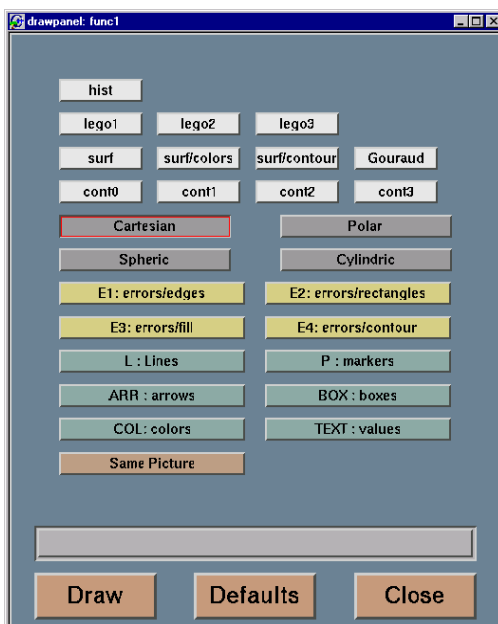

Try to resize the bottom slider and click `Draw`. You can zoom your graph. If you click on "lego2" and "Draw", you will see a 2D representation of your graph:

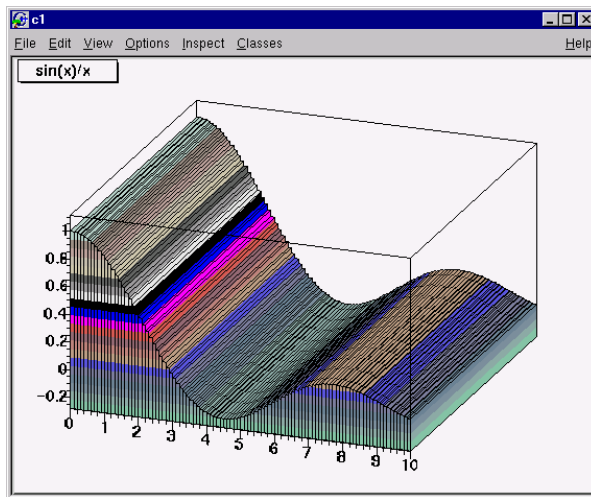

This 2D plot can be rotated interactively. Of course, ROOT is not limited to 1D graphs - it is possible to plot real 2D functions or graphs. There are numerous ways to change the graphical options/colors/fonts with the various methods available in the popup menu.

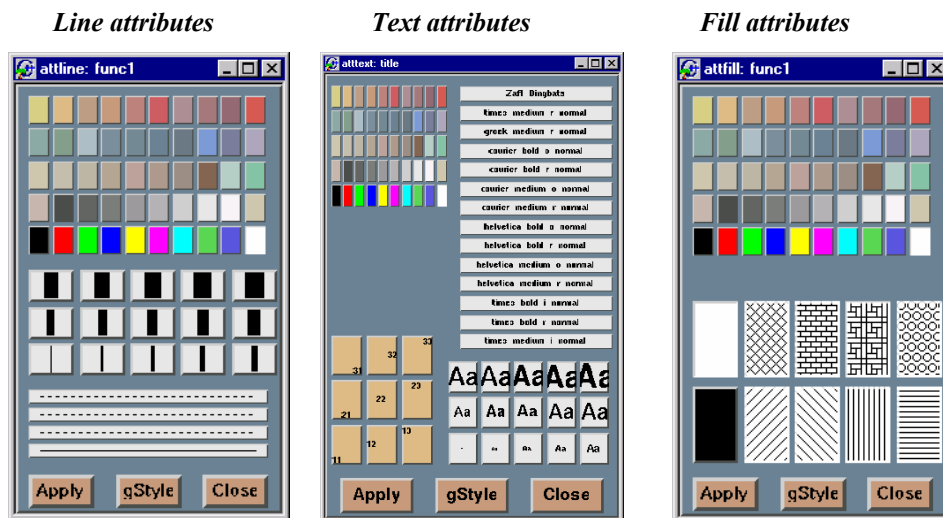

Once the picture suits your wishes, you may want to see the code you should put in a script to obtain the same result. To do that, choose the "Save as canvas.C" option in the "File" menu. This will generate a script showing the various options. Notice that you can also save the picture in PostScript or GIF format. One other interesting possibility is to save your canvas in native ROOT format. This will enable you to open it again and to change whatever you like, since all the objects associated to the canvas (histograms, graphs) are saved at the same time.

Second Example: Building a Multi-pad Canvas

Let's now try to build a canvas (i.e. a window) with several pads. The pads are sub-windows that can contain other pads or graphical objects.

```
root[] TCanvas *MyC = new TCanvas("MyC", "Test canvas", 1)
root[] MyC->Divide(2, 2)
```

Once again, we called the constructor of a class, this time the class `TCanvas`. The difference with the previous constructor call is that we want to build an object with a pointer to it. Next, we call the method `Divide` of the `TCanvas` class (that is `TCanvas::Divide`), which divides the canvas into four zones and sets up a pad in each of them.

```
root[] MyC->cd(1)
root[] f1->Draw()
```

Now, the function `f1` will be drawn in the first pad. All objects will now be drawn in that pad. To change the active pad, there are three ways:

1/ Click on the middle button of the mouse on an object, for example a pad. This sets this pad as the active one.

2/ Use the method `TCanvas::cd` with the pad number, as was done in the example above:

```
root[] MyC->cd(3)
```

Pads are numbered from left to right and from top to bottom.

Each new pad created by `TCanvas::Divide` has a name, which is the name of the canvas followed by `_1`, `_2`, etc. For example to apply the method `cd()` to the third pad, you would write:

```
root[] MyC_3->cd()
```

3/ Third pad will be selected since you called `TPad::cd()` for the object `MyC_3`. ROOT automatically found the pad that was named `MyC_3` when you typed it on the command line (see ROOT/CINT Extensions to C++).

The obvious question is: what is the relation between a canvas and a pad? In fact, a canvas is a pad that spans through an entire window. This is nothing else than the notion of inheritance. The `TPad` class is the parent of the `TCanvas` class.

Printing the Canvas

To print a canvas click on the `File` menu and select `Print`. This will create a postscript file containing the canvas with name `<canvasname>.ps`. Then you can send the postscript file to your printer.

The ROOT Command Line

We have briefly touched on how to use the command line, and you probably saw that there are different types of commands.

1. CINT commands start with “.”

```
root[] .? //this command will list all the CINT commands
root[] .L <filename> //load [filename]
root[] .x <filename> //load and execute [filename]
```

2. SHELL commands start with “.!” for example:

```
root[] .! ls
```

3. C++ commands follow C++ syntax (almost)

```
root[] TBrowser *b = new TBrowser()
```

CINT Extensions

We can see that some things are not standard C++. The CINT interpreter has several extensions. See the section [ROOT/CINT Extensions to C++](#) in chapter [CINT the C++ Interpreter](#)

Helpful Hints for Command Line Typing

The interpreter knows all the classes, functions, variables, and user defined types. This enables ROOT to help the user complete the command line. For example we do not know yet anything about the `TLine` class. We can use the Tab feature to get help. Where `<TAB>` means type the `<TAB>` key. This lists all the classes starting with `TL`.

```
root[] l = new TL<TAB>
TLeaf
TLeafB
TLeafC
TLeafD
TLeafF
TLeafI
TLeafObject
TLeafS
TLine
TLatex
TLegendEntry
TLegend
TLink
TList
TListIter
TLazyMatrix
TLazyMatrixD
```

This lists the different constructors and parameters for `TLine`.

```
root[] l = new TLine(<TAB>
TLine TLine()
TLine TLine(Double_t x1,Double_t y1,Double_t x2,Double_t y2)
TLine TLine(const TLine& line)
```

Multi-line Commands

You can use the command line to execute multi-line commands. To begin a multi-line command you must type a single left curly bracket `{`, and to end it you must type a single right curly bracket `}`.

For example:

```
root[] {
end with '}'> Int_t j = 0;
end with '}'> for (Int_t i = 0; i < 3; i++)
end with '}'> {
end with '}'> j= j + i;
end with '}'> cout << "i = " << i << ", j = " << j << endl;
end with '}'> }
end with '}'> }
i = 0, j = 0
i = 1, j = 1
i = 2, j = 3
```

It is more convenient to edit scripts than the command line, and if your multi line commands are getting unmanageable you may want to start a script instead.

Regular Expression

The meta-characters below can be used in a regular expression:

'^' start-of-line anchor
'\$' end-of-line anchor
'.' matches any character
'[' start a character class
 end a character class
'^' negates character class if first character
'*' Kleene closure (matches 0 or more)
'+' Positive closure (1 or more)
'?' Optional closure (0 or 1)

When using wildcards the regular expression is assumed to be preceded by a '^' (BOL) and terminated by '\$' (EOL). All '*' (closures) are assumed to be preceded by a '.', i.e. any character, except slash '_/_. Its special treatment allows the easy matching of pathnames. For example, `_*.*root_` will match `_aap.root_`, but not `_pipo/aap.root_`.

The escape characters are:

\\ backslash
\b backspace
\f form feed
\n new line
\r carriage return
\s space
\t tab
\e ASCII ESC character ('\033')
\DDD number formed of 1-3 octal digits
\xDD number formed of 1-2 hex digits
\^C C = any letter. Control code

The class **TRegexp** can be used to create a regular expression from an input string. If `wildcard` is true then the input string contains a wildcard expression.

```
TRegexp(const char *re, Bool_t wildcard)
```

Regular expression and wildcards can be easily used in methods like:

```
Ssiz_t Index(const TString& string, Ssiz_t* len, Ssiz_t i) const
```

which finds the first occurrence of the regular expression in the `string` and returns its position.

Conventions

In this paragraph, we will explain some of the conventions used in ROOT source and examples.

Coding Conventions

From the first days of ROOT development, it was decided to use a set of coding conventions. This allows a consistency throughout the source code. Learning these will help you identify what type of information you are dealing with and enable you to understand the code better and quicker. Of course, you can use whatever convention you want but if you are going to submit some code for inclusion into the ROOT sources you will need to use these.

These are the coding conventions:

- Classes begin with **T**: TLine, TTree
- Non-class types end with **_t**: Int_t
- Data members begin with **f**: fTree
- Member functions begin with a capital: Loop()
- Constants begin with **k**: kInitialSize, kRed
- Global variables begin with **g**: gEnv
- Static data members begin with **fg**: fgTokenClient
- Enumeration types begin with **E**: EColorLevel
- Locals and parameters begin with a lower case: nbytes
- Getters and setters begin with **Get** and **Set**: SetLast(), GetFirst()

Machine Independent Types

Different machines may have different lengths for the same type. The most famous example is the `int` type. It may be 16 bits on some old machines and 32 bits on some newer ones. To ensure the size of your variables, use these pre defined types in ROOT:

- `Char_t` Signed Character 1 byte
- `Uchar_t` Unsigned Character 1 byte
- `Short_t` Signed Short integer 2 bytes
- `UShort_t` Unsigned Short integer 2 bytes
- `Int_t` Signed integer 4 bytes
- `UInt_t` Unsigned integer 4 bytes
- `Long_t` Signed long integer 8 bytes
- `ULong_t` Unsigned long integer 8 bytes
- `Float_t` Float 4 bytes
- `Double_t` Float 8 bytes
- `Bool_t` Boolean (0=false, 1=true)

If you do not want to save a variable on disk, you can use `int` or `Int_t`, the result will be the same and the interpreter or the compiler will treat them in exactly the same way.

TObject

In ROOT, almost all classes inherit from a common base class called `TObject`. This kind of architecture is also used in the Java language. The `TObject` class provides default behavior and protocol for all objects in the ROOT system. The main advantage of this approach is that it enforces the common behavior of the derived classes and consequently it ensures the consistency of the whole system.

`TObject` provides protocol, i.e. (abstract) member functions, for:

- Object I/O (`Read()`, `Write()`)
- Error handling (`Warning()`, `Error()`, `SysError()`, `Fatal()`)
- Sorting (`IsSortable()`, `Compare()`, `IsEqual()`, `Hash()`)
- Inspection (`Dump()`, `Inspect()`)
- Printing (`Print()`)
- Drawing (`Draw()`, `Paint()`, `ExecuteEvent()`)
- Bit handling (`SetBit()`, `TestBit()`)
- Memory allocation (`operator new` and `delete`, `IsOnHeap()`)
- Access to meta information (`IsA()`, `InheritsFrom()`)
- Object browsing (`Browse()`, `IsFolder()`)

See "The Role of `TObject`" in the chapter ["Adding a Class"](#)

Global Variables

ROOT has a set of global variables that apply to the session. For example, *gDirectory* always holds the current directory, and *gStyle* holds the current style. All global variables begin with “g” followed by a capital letter.

gROOT

The single instance of **TROOT** is accessible via the global *gROOT* and holds information relative to the current session. By using the *gROOT* pointer you get the access to basically every object created in a ROOT program. The **TROOT** object has several lists pointing to the main ROOT objects.

The Collections of gROOT

During a ROOT session, the *gROOT* keeps a series of collections to manage objects. These can be accessed with the *gROOT::GetListOf...* methods

```
gROOT->GetListOfClasses()
gROOT->GetListOfColors()
gROOT->GetListOfTypes()
gROOT->GetListOfGlobals()
gROOT->GetListOfGlobalFunctions()
gROOT->GetListOfFiles()
gROOT->GetListOfMappedFiles()
gROOT->GetListOfSockets()
gROOT->GetListOfCanvases()
gROOT->GetListOfStyles()
gROOT->GetListOfFunctions()
gROOT->GetListOfSpecials()
gROOT->GetListOfGeometries()
gROOT->GetListOfBrowsers()
gROOT->GetListOfMessageHandlers()
```

These methods return a **TSeqCollection**, meaning a collection of objects, and they can be used to do list operations such as finding an object, or traversing the list and calling a method for each of the members. See the **TCollection** class description for the full set of methods supported for a collection.

For example, to find a canvas called *c1*:

```
root[] gROOT->GetListOfCanvases()->FindObject("c1")
```

This returns a pointer to a **TObject**, and before you can use it as a canvas you will need cast it to a **TCanvas***.

gFile

gFile is the pointer to the current opened file.

gDirectory

gDirectory is a pointer to the current directory. The concept and role of a directory is explained in chapter [Input/Output](#)

gPad

A graphic object is always drawn on the active pad. It is convenient to access the active pad, no matter what it is. For that we have *gPad* that is always pointing to the active pad. For example, if you want to change the fill color of the active pad to blue, but you do not know its name, you can use *gPad*.

```
root[] gPad->SetFillColor(38)
```

To get the list of colors, if you have an open canvas, click in the "View" menu, selecting the "Colors" entry.

gRandom

gRandom is a pointer to the current random number generator. By default, it points to a **TRandom** object. Setting the seed to 0 implies that the seed will be generated from the time. Any other value will be used as a constant.

The following basic random distributions are provided:

```
Gaus(mean, sigma)
Rndm()
Landau(mean, sigma)
Poisson(mean)
Binomial(ntot, prob)
```

You can customize your ROOT session by replacing the random number generator. You can delete **gRandom** and recreate it with your own:

```
root[] delete gRandom;
root[] gRandom = new TRandom3(0); //seed=0
```

TRandom3 derives from **TRandom** and is a very fast generator with higher periodicity.

gEnv

gEnv is the global variable (of type **TEnv**) with all the environment settings for the current session. This variable is set by reading the contents of a `.rootrc` file (or `$ROOTSYS/etc/system.rootrc`) at the beginning of the session. See "Environment Setup" below for more information.

History File

You can use the up and down arrow at the command line, to access the previous and next command. The commands are recorded in the history file `$HOME/.root_hist`. It contains the last 100 commands. It is a text file, and you can edit and cut and paste from it.

You can specify the history file in the `system.rootrc` file (see below), by setting the `Rint.History` option. You can also turn off the command logging in the `system.rootrc` file with the option: `Rint.History: -`

Environment Setup

The behavior of a ROOT session can be tailored with the options in the `rootrc` file. At start-up, ROOT looks for a `rootrc` file in the following order:

- `./rootrc` //local directory
- `$HOME/.rootrc` //user directory
- `$ROOTSYS/etc/system.rootrc` //global ROOT directory

If more than one `rootrc` file is found in the search paths above, the options are merged, with precedence local, user, global.

While in a session, to see current settings, you can do:

```
root[] gEnv->Print()
```

The `rootrc` file typically looks like:

```
# Path used by dynamic loader to find shared libraries
Unix.*.Root.DynamicPath:  .:~/rootlibs:$ROOTSYS/lib
Unix.*.Root.MacroPath:    .:~/rootmacros:$ROOTSYS/macros

# Path where to look for TrueType fonts
Unix.*.Root.UseTTFonts:   true
Unix.*.Root.TTFontPath:

...
# Activate memory statistics
Rint.Root.MemStat:        1
Rint.Load:                 rootalias.C
Rint.Logon:                rootlogon.C
Rint.Logoff:               rootlogoff.C
...
Rint.Canvas.MoveOpaque:   false
Rint.Canvas.HighLightColor: 5
```

The various options are explained in `$ROOTSYS/etc/system.rootrc`.

The `.rootrc` file contents are combined. For example, if the flag to use true type fonts is set to true in one of the `system.rootrc` files, you have to explicitly overwrite it and set it to false. Removing the `UseTTFonts` statement in the local `.rootrc` file will not disable true fonts.

The Script Path

ROOT looks for scripts in the path specified in the `rootrc` file in the `Root.Macro.Path` variable. You can expand this path to hold your own directories.

Logon and Logoff Scripts

The `rootlogon.C` and `rootlogoff.C` files are script loaded and executed at start-up and shutdown. The `rootalias.C` file is loaded but not executed. It typically contains small utility functions. For example, the `rootalias.C` script that comes with the ROOT distributions and is in the `$ROOTSYS/tutorials` defines the function `edit(char *file)`. This allows the user to call the editor from the command line. This particular function will start the VI editor if the environment variable `EDITOR` is not set.

```
root[0] edit("c1.C")
```

For more details, see `$ROOTSYS/tutorials/rootalias.C`.

Tracking Memory Leaks

You can track memory usage and detect leaks by monitoring the number of objects that are created and deleted (see `TObjectTable`). To use this facility, edit the file `.rootrc` if you have this file or `$ROOTSYS/etc/system.rootrc` and edit or add the two following lines:

```
Root.MemStat:          1
Root.ObjectStat:       1
```

In your code or on the command line you can type the line:

```
gObjectTable->Print();
```

This line will print the list of active classes and the number of instances for each class. By comparing consecutive print outs, you can see objects that you forgot to delete.

Note that this method cannot show leaks coming from the allocation of non-objects or classes unknown to ROOT.

Memory Checker

A memory checking system was developed by D.Bertini and M.Ivanov and added in ROOT version 3.02.07.

To activate the memory checker you can set the resource `Root.MemCheck` to 1 (e.g.: `Root.MemCheck: 1`) in the `.rootrc` file. You also have to link with `libNew.so` (e.g. use `root-config --new --libs`) or use `rootn.exe`. When these settings are in place, you will find a file "memcheck.out" in the directory where you started your ROOT program after the completion of the program execution.

You can also set the resource `Root.MemCheckFile` to the name of a file. The memory information will be written to that file. The contents of this `memcheck.out` can be analyzed and transformed into printable text via the `memprobe` program (in `$ROOTSYS/bin`).

Converting HBOOK/PAW Files

ROOT has a utility called `h2root` that you can use to convert your HBOOK/PAW histograms or ntuples files into ROOT files. To use this program, you type the shell script command:

```
h2root <hbookfile> <rootfile>
```

If you do not specify the second parameter, a file name is automatically generated for you. If `hbookfile` is of the form `file.hbook`, then the ROOT file will be called `file.root`.

This utility converts HBOOK histograms into ROOT histograms of the class `TH1F`. HBOOK profile histograms are converted into ROOT profile histograms (see class `TProfile`). HBOOK row-wise and column-wise ntuples are automatically converted to ROOT Trees (see the chapter on [Trees](#)). Some HBOOK column-wise ntuples may not be fully converted if the columns are an array of fixed dimension (e.g. `var[6]`) or if they are a multi-dimensional array.

HBOOK integer identifiers are converted into ROOT named objects by prefixing the integer identifier with the letter "h" if the identifier is a positive integer and by "h_" if it is a negative integer identifier. In case of row-wise or column-wise ntuples, each column is converted to a branch of a tree. Note that `h2root` is able to convert HBOOK files containing several levels of sub-directories.

Once you have converted your file, you can look at it and draw histograms or process ntuples using the ROOT command line. An example of session is shown below:

```
// this connects the file hbookconverted.root
root[] TFile f("hbookconverted.root");

//display histogram named h10 (was HBOOK id 10)
root[] h10.Draw();

//display column "var" from ntuple h30
root[] h30.Draw("var");
```

You can also use the ROOT browser (see `TBrowser`) to inspect this file.

The chapter on trees explains how to read a tree. ROOT includes a function `TTree::MakeClass` to automatically generate the code for a skeleton analysis function (see the chapter [Example Analysis](#))

In case one of the ntuple columns has a variable length (e.g. `px(ntrack)`), `h.Draw("px")` will histogram the `px` column for all tracks in the same histogram. Use the script quoted above to generate the skeleton function and create/fill the relevant histogram yourself.

3 Histograms

This chapter covers the functionality of the histogram classes. We begin with an overview of the histogram classes and their inheritance relationship. Then we give instructions on the histogram features.

We have put this chapter ahead of the graphics chapter so that you can begin working with histograms as soon as possible. Some of the examples have graphics commands that may look unfamiliar to you. These are covered in the chapter on [Input/Output](#).

The Histogram Classes

ROOT supports the following histogram types:

1-D histograms:

- **TH1C**: are histograms with one byte per channel. Maximum bin content = 255
- **TH1S**: are histograms with one short per channel. Maximum bin content = 65 535
- **TH1F**: are histograms with one float per channel. Maximum precision 7 digits
- **TH1D**: are histograms with one double per channel. Maximum precision 14 digits

2-D histograms:

- **TH2C**: are histograms with one byte per channel. Maximum bin content = 255
- **TH2S**: are histograms with one short per channel. Maximum bin content = 65 535
- **TH2F**: are histograms with one float per channel. Maximum precision 7 dig
- **TH2D**: are histograms with one double per channel. Maximum precision 14 digits

3-D histograms:

- **TH3C**: are histograms with one byte per channel. Maximum bin content = 255
- **TH3S**: are histograms with one short per channel. Maximum bin content = 65 535
- **TH3F**: are histograms with one float per channel. Maximum precision 7 digits
- **TH3D**: are histograms with one double per channel. Maximum precision 14 digits

Profile histograms:

- **TProfile**: one dimensional profiles
- **TProfile2D**: two dimensional profiles

Profile histograms are used to display the mean value of Y and its RMS for each bin in X. Profile histograms are in many cases an elegant replacement of two-dimensional histograms. The inter-relation of two measured quantities X and Y can always be visualized with a two-dimensional histogram or scatter-plot. If Y is an unknown but single-valued approximate function of X, it will have greater precisions in a profile histogram than in a scatter plot.

All histogram classes are derived from the base class **TH1**. The next image shows the class hierarchy of the histogram classes.

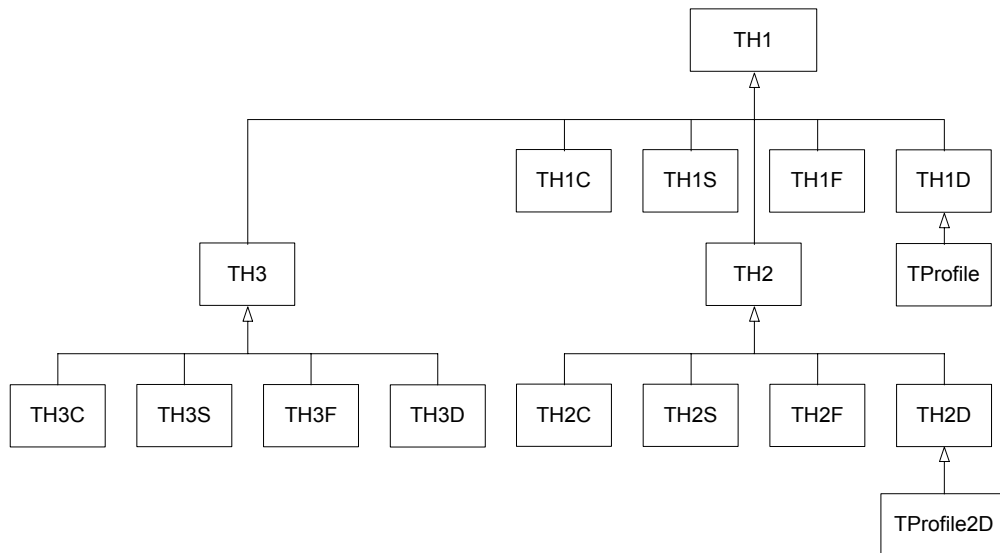

The **TH*C** classes also inherit from the array class **TArrayC**.

The **TH*S** classes also inherit from the array class **TArrayS**.

The **TH*F** classes also inherit from the array class **TArrayF**.

The **TH*D** classes also inherit from the array class **TArrayD**.

The histogram classes have a rich set of methods. Below is a list of what one can do with the histogram classes.

Creating Histograms

Histograms are created with constructors:

```

TH1F *h1 = new TH1F("h1", "h1 title", 100, 0, 4.4);
TH2F *h2 = new TH2F("h2", "h2 title", 40, 0, 4, 30, -3, 3);
  
```

The parameters to the **TH1** constructor are: the name of the histogram, the title, the number of bins, the x minimum, and x maximum.

Histograms may also be created by:

- Calling the `Clone` method of an existing histogram (see below)
- Making a projection from a 2-D or 3-D histogram (see below)
- Reading a histogram from a file

When a histogram is created, a reference to it is automatically added to the list of in-memory objects for the current file or directory. This default behavior can be disabled for an individual histogram or for all histograms by setting a global switch.

Here is the syntax to set the directory of a histogram:

```

// to set the in-memory directory for h the current histogram
h->SetDirectory(0);

// global switch to disable
TH1::AddDirectory(kFALSE);
  
```

When the histogram is deleted, the reference to it is removed from the list of objects in memory. In addition, when a file is closed, all histograms in memory associated with this file are automatically deleted. See chapter [Input/Output](#).

Fixed or Variable Bin Size

All histogram types support fixed or variable bin sizes. 2-D histograms may have fixed size bins along X and variable size bins along Y or vice-versa. The functions to fill, manipulate, draw, or access histograms are identical in both cases.

To create a histogram with variable bin size one can use this constructor:

```
TH1(const char name, const *title, Int_t nbins, *xbins)
```

The parameters to this constructor are:

- `title`: histogram title
- `nbins`: number of bins
- `xbins`: array of low-edges for each bin. It is an array of size `nbins+1`

Each histogram always contains three **TAxis** objects: `fXaxis`, `fYaxis`, and `fZaxis`. To access the axis parameters first get the axis from the histogram, and then call the **TAxis** access methods.

```
TAxis *xaxis = h->GetXaxis();  
Double_t binCenter = xaxis->GetBinCenter(bin);
```

See class **TAxis** for a description of all the access methods. The axis range is always stored internally in double precision.

Bin Numbering Convention

For all histogram types: `nbins`, `xlow`, `xup`

Bin# 0 contains the underflow.

Bin# 1 contains the first bin with low-edge (`xlow` INCLUDED).

The second to last bin (bin# `nbins`) contains the upper-edge (`xup` EXCLUDED).

The Last bin (bin# `nbins+1`) contains the overflow.

In case of 2-D or 3-D histograms, a "global bin" number is defined. For example, assuming a 3-D histogram with `binx`, `biny`, `binz`, the function returns a global/linear bin number.

```
Int_t bin = h->GetBin(binx, biny, binz);
```

This global bin is useful to access the bin information independently of the dimension.

Re-binning

At any time, a histogram can be re-binned via the `TH1::Rebin` method. It returns a new histogram with the re-binned contents. If bin errors were stored, they are recomputed during the re-binning.

Filling Histograms

A histogram is typically filled with statements like:

```
h1->Fill(x);  
h1->Fill(x, w); //with weight  
h2->Fill(x, y);  
h2->Fill(x, y, w);  
h3->Fill(x, y, z);  
h3->Fill(x, y, z, w);
```

The `Fill` method computes the bin number corresponding to the given `x`, `y` or `z` argument and increments this bin by the given weight. The `Fill()` method returns the bin number

for 1-D histograms or global bin number for 2-D and 3-D histograms. If `TH1::Sumw2()` has been called before filling, the sum of squares is also stored.

One can also increment a bin number directly by calling `TH1::AddBinContent`. Replace the existing content via `TH1::SetBinContent`, and access the bin content of a given bin via `TH1::GetBinContent`.

```
Double_t binContent = h->GetBinContent(bin);
```

Automatic Re-binning Option

By default, the number of bins is computed using the range of the axis. You can change this to automatically re-bin by setting the automatic re-binning option:

```
h->SetBit(TH1::kCanRebin);
```

Once this is set, the `Fill` method will automatically extend the axis range to accommodate the new value specified in the `Fill` argument. The method used is to double the bin size until the new value fits in the range, merging bins two by two.

This automatic binning option is extensively used by the `TTree::Draw` function when drawing histograms of variables in `TTree` with an unknown range. The automatic binning option is supported for 1-D, 2-D and 3-D histograms.

During filling, some statistics parameters are incremented to compute the mean value and root mean square with the maximum precision. In case of histograms of type `TH1C`, `TH1S`, `TH2C`, `TH2S`, `TH3C`, `TH3S` a check is made that the bin contents do not exceed the maximum positive capacity (127 or 65 535). Histograms of all types may have positive or/and negative bin contents.

Random Numbers and Histograms

`TH1::FillRandom` can be used to randomly fill a histogram using the contents of an existing `TF1` function or another `TH1` histogram (for all dimensions). For example, the following two statements create and fill a histogram 10 000 times with a default Gaussian distribution of mean 0 and sigma 1:

```
TH1F h1("h1","histo from a gaussian",100,-3,3);  
h1.FillRandom("gaus",10000);
```

`TH1::GetRandom` can be used to return a random number distributed according to the contents of a histogram.

To fill a histogram following the distribution in an existing histogram you can use the second signature of `TH1::FillRandom`.

This code snippet assumes that `h` is an existing histogram (`TH1`).

```
root[] TH1F h2("h2","Random Histo",100,-3,3);  
root[] h2->FillRandom(h,1000);
```

The distribution contained in the histogram `h` (`TH1`) is integrated over the channel contents. It is normalized to 1. Getting one random number implies:

- Generating a random number between 0 and 1 (say `r1`)
- Find the bin in the normalized integral for `r1`
- Fill histogram channel

The second parameter (1000) indicates how many random numbers are generated.

Adding, Dividing, and Multiplying

Many types of operations are supported on histograms or between histograms:

- Addition of a histogram to the current histogram
- Additions of two histograms with coefficients and storage into the current histogram
- Multiplications and divisions are supported in the same way as additions.
- The `Add`, `Divide` and `Multiply` functions also exist to add, divide or multiply a histogram by a function.

If a histogram has associated error bars (`TH1::Sumw2` has been called), the resulting error bars are also computed assuming independent histograms. In case of divisions, binomial errors are also supported.

Projections

One can:

- Make a 1-D projection of a 2-D histogram or Profile. See functions `TH2::ProjectionX`, `TH2::ProjectionY`, `TH2::ProfileX`, `TH2::ProfileY`, `TProfile::ProjectionX`, `TProfile2D::ProjectionXY`
- Make a 1-D, 2-D or profile out of a 3-D histogram see functions `TH3::ProjectionZ`, `TH3::Project3D`.

One can fit these projections via: `TH2::FitSlicesX`, `TH2::FitSlicesY`, `TH3::FitSlicesZ`.

Drawing Histograms

When you call the `Draw` method of a histogram (`TH1::Draw`) for the first time, it creates a `THistPainter` object and saves a pointer to painter as a data member of the histogram. The `THistPainter` class specializes in the drawing of histograms. It allows logarithmic axes (x, y, z) when the `CONT` drawing option is using. The `THistPainter` class is separated from the histogram so that one can have histograms without the graphics overhead, for example in a batch program. The choice to give each histogram has its own painter rather than a central singleton painter, allows two histograms to be drawn in two threads without overwriting the painter's values.

When a displayed histogram is filled again, you do not have to call the `Draw` method again. The image is refreshed the next time the pad is updated. A pad is updated after one of these three actions:

- A carriage control on the ROOT command line
- A click inside the pad
- A call to `TPad::Update`

By default, a call to `TH1::Draw` clears the pad of all objects before drawing the new image of the histogram. You can use the `"SAME"` option to leave the previous display in tact and superimpose the new histogram. The same histogram can be drawn with different graphics options in different pads.

When a displayed histogram is deleted, its image is automatically removed from the pad.

To create a copy of the histogram when drawing it, you can use `TH1::DrawClone`. This will clone the histogram and allow you to change and delete the original one without affecting the clone.

You can use `TH1::DrawNormalized` to draw a normalized copy of a histogram.

```
TH1 *TH1::DrawNormalized(Option_t *option, Double_t norm) const
```

A clone of this histogram is normalized to `norm` and drawn with `option`. A pointer to the normalized histogram is returned. The contents of the histogram copy are scaled such that the new sum of weights (excluding under and overflow) is equal to `norm`.

Note that the returned normalized histogram is not added to the list of histograms in the current directory in memory. It is the user's responsibility to delete this histogram. The `kCanDelete` bit is set for the returned object. If a pad containing this copy is cleared, the histogram will be automatically deleted. See the chapter *'Draw Options'* for the list of options.

Setting the Style

Histograms use the current style `gStyle`, which is the global object of class `TStyle`. To change the current style for histograms, the `TStyle` class provides a multitude of methods ranging from setting the fill color to the axis tick marks. Here are a few examples:

```
void SetHistFillColor(Color_t color = 1)
void SetHistFillStyle(Style_t styl = 0)
void SetHistLineColor(Color_t color = 1)
void SetHistLineStyle(Style_t styl = 0)
void SetHistLineWidth(Width_t width = 1)
```

When you change the current style and would like to propagate the change to a previously created histogram you can call `TH1::UseCurrentStyle`. You will need to call `UseCurrentStyle` on each histogram.

When reading many histograms from a file and you wish to update them to the current style you can use `gROOT::ForceStyle` and all histograms read after this call will be updated to use the current style (also see the chapter *Graphics and Graphic User Interfaces*) When a histogram is automatically created as a result of a `TTree::Draw`, the style of the histogram is inherited from the tree attributes and the current style is ignored. The tree attributes are the ones set in the current `TStyle` at the time the tree was created. You can change the existing tree to use the current style, by calling `TTree::UseCurrentStyle()`.

Draw Options

The following draw options are supported on all histogram classes:

- "AXIS": Draw only the axis
- "HIST": When an histogram has errors it is visualized by default with error bars. To visualize it without errors use the option `HIST` together with the required option (e.g. "HIST SAME C")
- "SAME": Superimpose on previous picture in the same pad
- "CYL": Use cylindrical coordinates
- "POL": Use polar coordinates
- "SPH": Use spherical coordinates
- "PSR": Use pseudo-rapidity/phi coordinates
- "LEGO": Draw a lego plot with hidden line removal
- "LEGO1": Draw a lego plot with hidden surface removal
- "LEGO2": Draw a lego plot using colors to show the cell contents
- "SURF": Draw a surface plot with hidden line removal
- "SURF1": Draw a surface plot with hidden surface removal
- "SURF2": Draw a surface plot using colors to show the cell contents
- "SURF3": Same as `SURF` with a contour view on the top
- "SURF4": Draw a surface plot using Gouraud shading
- "SURF5": Same as `SURF3` but only the colored contour is drawn. Used with option `CYL`, `SPH` or `PSR` it allows to draw colored contours on a sphere, a cylinder or in a pseudo rapidly space. In Cartesian or polar coordinates, option `SURF3` is used.

The following options are supported for 1-D histogram classes:

- "AH": Draw the histogram, but not the axis labels and tick marks
- "B": Draw a bar chart
- "C": Draw a smooth curve through the histogram bins
- "E": Draw the error bars
- "E0": Draw the error bars including bins with 0 contents
- "E1": Draw the error bars with perpendicular lines at the edges
- "E2": Draw the error bars with rectangles
- "E3": Draw a fill area through the end points of the vertical error bars
- "E4": Draw a smoothed filled area through the end points of the error bars
- "L": Draw a line through the bin contents
- "P": Draw a (Poly) marker at each bin using the histogram's current marker style
- "P0": Draw current marker at each bin including empty bins
- "*H": Draw histogram with a * at each bin
- "LF2": Draw histogram as with option "L" but with a fill area. Note that "L" also draws a fill area if the histogram fill color is set but the fill area corresponds to the histogram contour.
- "9": Force histogram to be drawn in high resolution mode. By default, the histogram is drawn in low resolution in case the number of bins is greater than the number of pixels in the current pad
- "]" [" : Draw histogram without the vertical lines for the first and the last bin. Use it when superposing many histograms on the same picture.

The following options are supported for 2-D histogram classes:

- "ARR": Arrow mode. Shows gradient between adjacent cells
- "BOX": Draw a box for each cell with surface proportional to contents
- "COL": Draw a box for each cell with a color scale varying with contents
- "COLZ": Same as "COL" with a drawn color palette
- "CONT": Draw a contour plot (same as `CONT0`)
- "CONTZ": Same as "CONT" with a drawn color palette
- "CONT0": Draw a contour plot using surface colors to distinguish contours
- "CONT1": Draw a contour plot using line styles to distinguish contours
- "CONT2": Draw a contour plot using the same line style for all contours
- "CONT3": Draw a contour plot using fill area colors
- "CONT4": Draw a contour plot using surface colors (`SURF` option at `theta = 0`)
- "LIST": Generate a list of `TGraph` objects for each contour
- "FB": To be used with `LEGO` or `SURFACE`, suppress the Front-Box
- "BB": To be used with `LEGO` or `SURFACE`, suppress the Back-Box
- "SCAT": Draw a scatter-plot (default)
- "TEXT": Draw cell contents as text
- "[cutg]": Draw only the sub-range selected by the `TCutG` name "cutg".
- "Z": The "z" option can be specified with the options: `BOX`, `COL`, `CONT`, `SURF`, and `LEGO` to display the color palette with an axis indicating the value of the corresponding color on the right side of the picture.

Most options can be concatenated without spaces or commas, for example:

```
h->Draw("E1SAME");  
h->Draw("elsame");
```

The options are not case sensitive. The options `BOX`, `COL` and `COLZ`, use the color palette defined in the current style (see `TStyle::SetPalette`)

The options `CONT`, `SURF`, and `LEGO` have by default 20 equidistant contour levels, you can change the number of levels with `TH1::SetContour`.

You can also set the default drawing option with `TH1::SetOption`. To see the current option use `TH1::GetOption`. For example:

```
h->SetOption("lego");
h->Draw();           // will use the lego option
h->Draw("scat")     // will use the scatter plot option
```

Statistics Display

By default, drawing a histogram includes drawing the statistics box. To eliminate the statistics box use: `TH1::SetStats(kFALSE)`.

If the statistics box is drawn, you can select the type of information displayed with `gStyle->SetOptStat(mode)`. The mode has up to seven digits that can be set to on (1) or off (0). mode = iourmen (default = 0001111)

- n = 1 the name of histogram is printed
- e = 1 the number of entries printed
- m = 1 the mean value printed
- r = 1 the root mean square printed
- u = 1 the number of underflows printed
- o = 1 the number of overflows printed
- i = 1 the integral of bins printed

WARNING: never call `SetOptStat(000111)`; but `SetOptStat(1111)`, 0001111 will be taken as an octal number.

With the option "same", the statistic box is not redrawn. With the option "same", the statistic box is drawn. If it hides the previous statistics box, you can change its position with these lines (if h is the pointer to the histogram):

```
root[] TPaveStats *st =
      (TPaveStats*)h->GetListOfFunctions()->FindObject("stats");
root[] st->SetX1NDC (newx1); //new x start position
root[] st->SetX2NDC (newx2); //new x end position
```

Setting Line, Fill, Marker, and Text Attributes

The histogram classes inherit from the attribute classes: `TAttLine`, `TAttFill`, `TAttMarker` and `TAttText`. See the description of these classes for the list of options.

Setting Tick Marks on the Axis

The `TPad::SetTicks` method specifies the type of tick marks on the axis. Assume `tx = gPad->GetTickx()` and `ty = gPad->GetTicky()`.

- tx = 1; tick marks on top side are drawn (inside)
- tx = 2; tick marks and labels on top side are drawn
- ty = 1; tick marks on right side are drawn (inside)
- ty = 2; tick marks and labels on right side are drawn
- By default only the left Y axis and X bottom axis are drawn (tx=ty=0)

Use `TPad::SetTicks(tx,ty)` to set these options. See also The `TAxis` methods to set specific axis attributes. In case multiple color filled histograms are drawn on the same pad, the fill area may hide the axis tick marks. One can force a redraw of the axis over all the histograms by calling:

```
gPad->RedrawAxis();
```

Giving Titles to the X, Y and Z Axis

Because the axis title is an attribute of the axis, you have to get the axis first and then call `TH1Axis::SetTitle`.

```
h->GetXaxis()->SetTitle("X axis title");
h->GetYaxis()->SetTitle("Y axis title");
```

The histogram title and the axis titles can be any **TLatex** string. The titles are part of the persistent histogram. For example if you wanted to write E with a subscript (T) you could use this:

```
h->GetXaxis()->SetTitle("E_{T}");
```

For a complete explanation of the Latex mathematical expressions see chapter **"Graphics and Graphical User Interface"** It is also possible to specify the histogram title and the axis titles at creation time. These titles can be given in the "title" parameter. They must be separated by ";":

```
TH1F* h=new TH1F("h","Histogram title;X Axis;Y Axis;Z Axis",100,0,1);
```

Any title can be omitted:

```
TH1F* h=new TH1F("h","Histogram title;;Y Axis",100,0,1);
TH1F* h=new TH1F("h",";;Y Axis",100,0,1);
```

The method `SetTitle` has the same syntax:

```
h->SetTitle("Histogram title;An other X title Axis");
```

The SCATter Plot Option

By default, 2D histograms are drawn as scatter plots. For each cell (i, j) a number of points proportional to the cell content are drawn. A maximum of 500 points per cell are drawn. If the maximum is above 500 contents are normalized to 500.

The ARRow Option

The ARR option shows the gradient between adjacent cells. For each cell (i, j) an arrow is drawn. The orientation of the arrow follows the cell gradient

The BOX Option

For each cell (i, j) a box is drawn with surface proportional to contents.

The ERROR Bars Options

- 'E' Default. Draw only error bars, without markers
- 'E0' Draw also bins with 0 contents
- 'E1' Draw small lines at the end of error bars
- 'E2' Draw error rectangles
- 'E3' Draw a fill area through the end points of vertical error bars
- 'E4' Draw a smoothed filled area through the end points of error bars

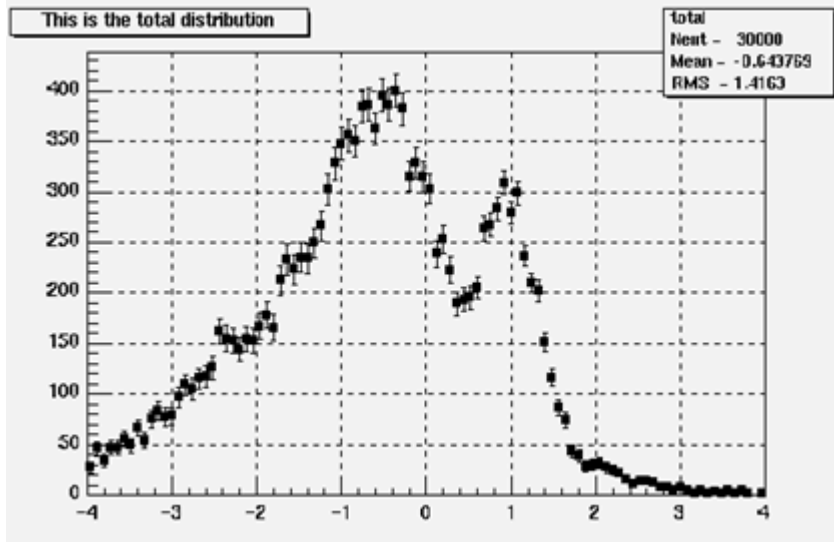

The Color Option

For each cell (i, j) a box is drawn with a color proportional to the cell content. The color table used is defined in the current style (*gStyle*). The color palette in *tStyle* can be modified with `tStyle::SetPalette`.

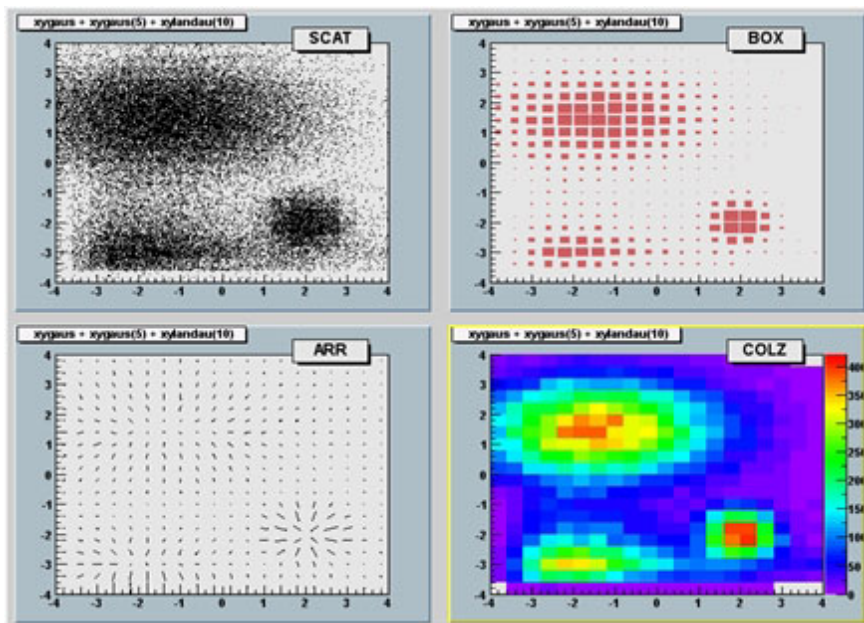

The TEXT Option

For each cell (i, j) the cell content is printed. The text attributes are:

- Text font = current `TStyle` font
- Text size = $0.02 * \text{pad-height} * \text{marker-size}$
- Text color = marker color

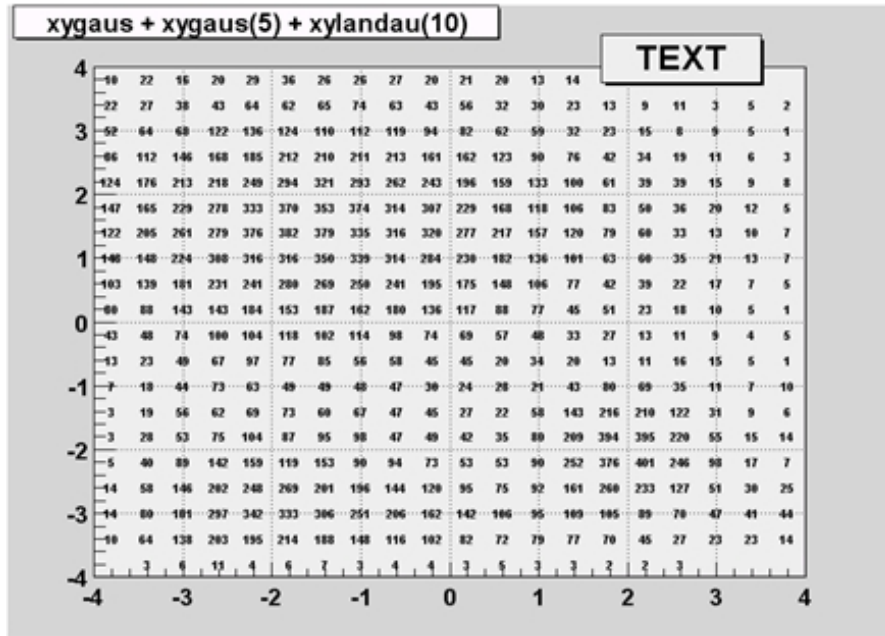

The CONTOur Options

The following contour options are supported:

- "CONT": Draw a contour plot (same as CONT0)
- "CONT0": Draw a contour plot using surface colors to distinguish contours
- "CONT1": Draw a contour plot using line styles to distinguish contours
- "CONT2": Draw a contour plot using the same line style for all contours
- "CONT3": Draw a contour plot using fill area colors
- "CONT4": Draw a contour plot using surface colors (SURF option at theta = 0)

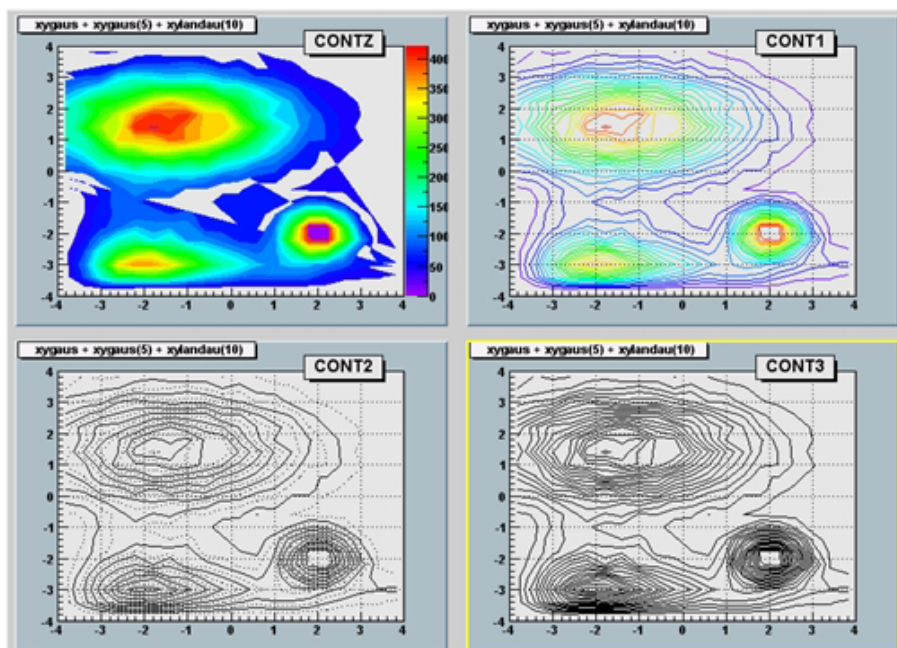

The default number of contour levels is 20 equidistant levels and can be changed with `TH1::SetContour`. When option "LIST" is specified together with option "CONT", the points used to draw the contours are saved in the `TGraph` object and are accessible in the following way:

```
TObjArray *contours = gROOT->GetListOfSpecials()->FindObject("contours");
Int_t ncontours = contours->GetSize();
TList *list = (TList*)contours->At(i);
```

Where "i" is a contour number and list contains a list of `TGraph` objects. For one given contour, more than one disjoint poly-line may be generated. The `TGraph` numbers per contour are given by `list->GetSize()`. Here we show how to access the first graph in the list.

```
TGraph *gr1 = (TGraph*)list->First();
```

The LEGO Options

In a lego plot, the cell contents are drawn as 3D boxes, with the height of the box proportional to the cell content. A lego plot can be represented in several coordinate systems; the default system is Cartesian coordinates. Other possible coordinate systems are CYL, POL, SPH, and PSR.

"LEGO": Draw a lego plot with hidden line removal
 "LEGO1": Draw a lego plot with hidden surface removal
 "LEGO2": Draw a lego plot using colors to show the cell contents

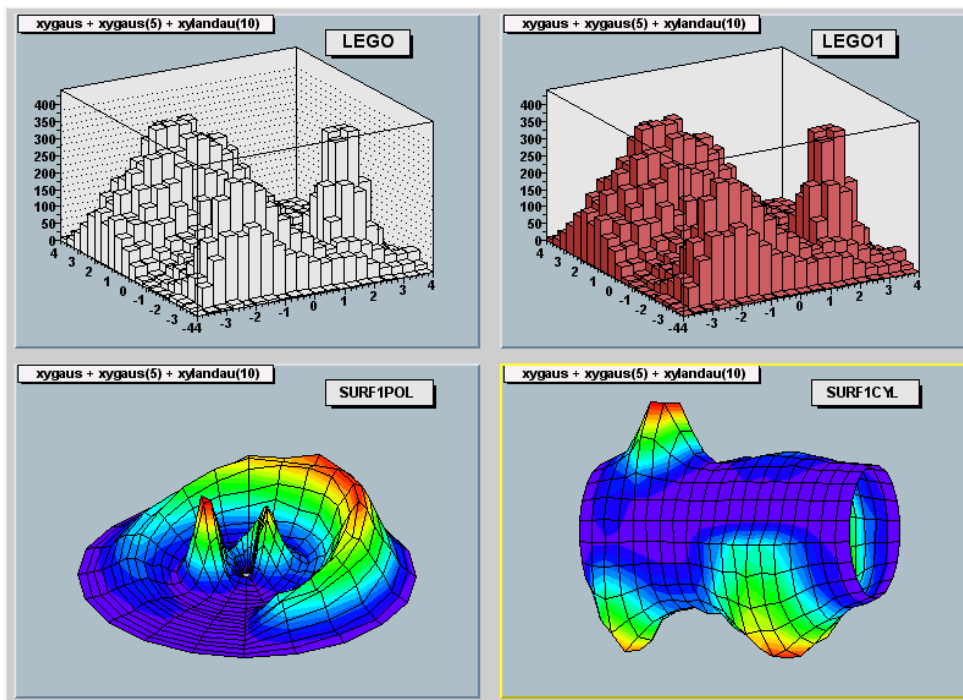

See `TStyle::SetPalette` to change the color palette. We suggest you use palette 1 with the call

```
gStyle->SetColorPalette(1);
```

The SURFace Options

In a surface plot, cell contents are represented as a mesh. The height of the mesh is proportional to the cell content. A surface plot can be represented in several coordinate systems. The default is Cartesian coordinates, and the other possible systems are `CYL`, `POL`, `SPH`, and `PSR`.

- "SURF": Draw a surface plot with hidden line removal
- "SURF1": Draw a surface plot with hidden surface removal
- "SURF2": Draw a surface plot using colors to show the cell contents
- "SURF3": Same as SURF with a contour view on the top
- "SURF4": Draw a surface plot using Gouraud shading

The following picture uses SURF1. See `Tstyle::SetPalette` to change the color palette. We suggest you use palette 1 with the call:

```
gStyle->SetColorPalette(1);
```

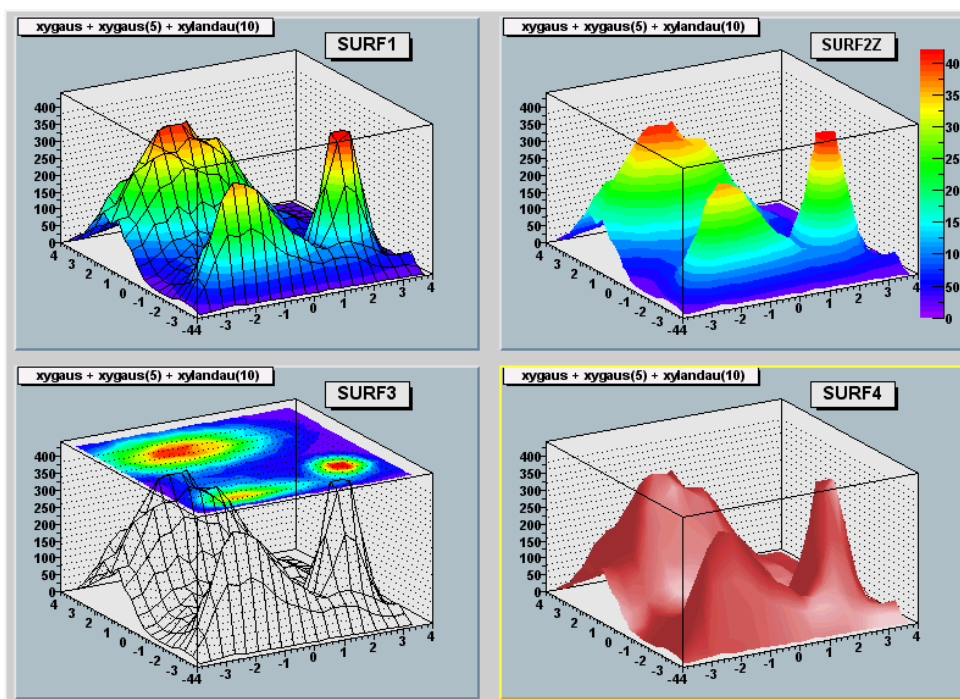

The BAR Options

When the option "bar" or "hbar" is specified, a bar chart is drawn.

Vertical BAR chart

The options are "bar", "bar0", "bar1", "bar2", "bar3", "bar4".

- The bar is filled with the histogram fill color.
- The left side of the bar is drawn with a light fill color
- The right side of the bar is drawn with a dark fill color
- The percentage of the bar drawn with either the light or dark color is:
 - 0 per cent for option "bar" or "bar0"
 - 10 per cent for option "bar1"
 - 20 per cent for option "bar2"
 - 30 per cent for option "bar3"
 - 40 per cent for option "bar4"

Use `TH1::SetBarWidth` to control the bar width (default is the bin width).
 Use `TH1::SetBarOffset` to control the bar offset (default is 0).
 See example in `$ROOTSYS/tutorials/hbars.C`

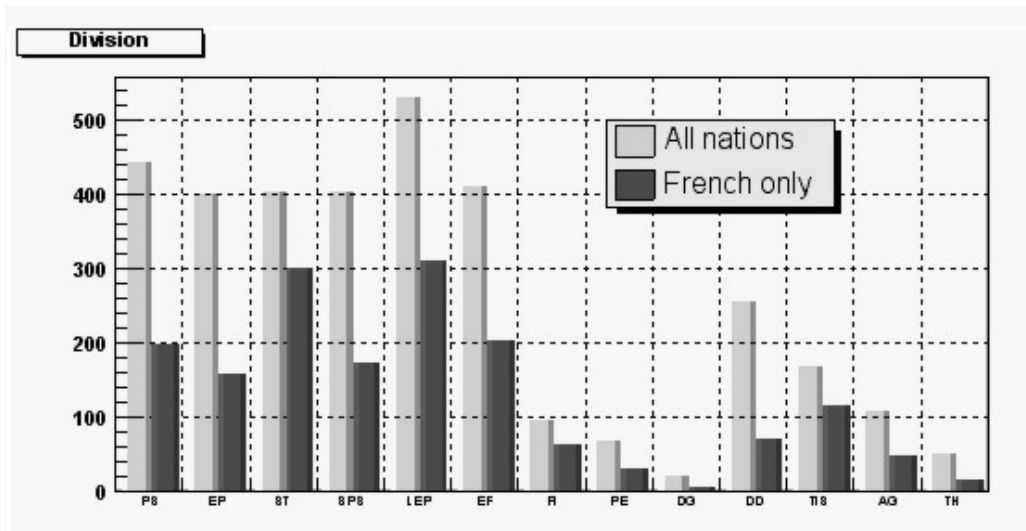

Horizontal BAR Chart

The options for the horizontal bar chart are:
`"hbar"`, `"hbar0"`, `"hbar1"`, `"hbar2"`, `"hbar3"`, `"hbar4"`

- A horizontal bar is drawn for each bin.
- The bar is filled with the histogram fill color
- The bottom side of the bar is drawn with a light fill color
- The top side of the bar is drawn with a dark fill color
- The percentage of the bar drawn with either the light or dark color is
 - 0 per cent for option `"hbar"` or `"hbar0"`
 - 10 per cent for option `"hbar1"`
 - 20 per cent for option `"hbar2"`
 - 30 per cent for option `"hbar3"`
 - 40 per cent for option `"hbar4"`

Use `TH1::SetBarWidth` to control the bar width (default is the bin width).
 Use `TH1::SetBarOffset` to control the bar offset (default is 0).
 See example in `$ROOTSYS/tutorials/hbars.C`

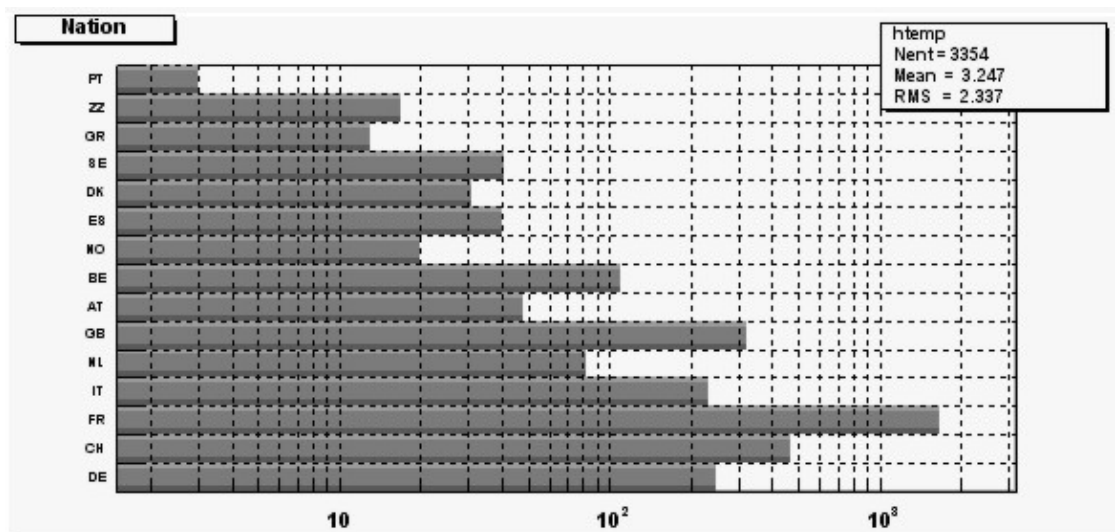

The Z Option: Display the Color Palette on the Pad

The "Z" option can be specified with the options: `BOX`, `COL`, `CONT`, `SURF`, and `LEGO` to display the color palette with an axis indicating the value of the corresponding color on the right side of the picture.

If there is not enough space on the right side, you can increase the size of the right margin by calling `TPad::SetRightMargin()`.

The attributes used to display the palette axis values are taken from the Z axis of the object. For example, you can set the labels size on the palette axis with:

```
hist->GetZaxis()->SetLabelSize();
```

Setting the Color Palette

You can set the color palette with `TStyle::SetPalette`, e.g.

```
gStyle->SetPalette(ncolors, colors);
```

For example, the option `COL` draws a 2-D histogram with cells represented by a box filled with a color index, which is a function of the cell content. If the cell content is `N`, the color index used will be the color number in `colors[N]`. If the maximum cell content is greater than `ncolors`, all cell contents are scaled to `ncolors`.

If `ncolors <= 0`, a default palette (see below) of 50 colors is defined. This palette is recommended for pads, labels.

If `ncolors == 1` && `colors == 0`, a pretty palette with a violet to red spectrum is created. We recommend you use this palette when drawing lego plots, surfaces, or contours.

If `ncolors > 0` and `colors == 0`, the default palette is used with a maximum of `ncolors`.

The default palette defines:

- Index 0 to 9: shades of gray
- Index 10 to 19: shades of brown
- Index 20 to 29: shades of blue
- Index 30 to 39: shades of red
- Index 40 to 49: basic colors

The color numbers specified in the palette can be viewed by selecting the item "colors" in the "VIEW" menu of the canvas toolbar. The color's red, green, and blue values can be changed via `TColor::SetRGB`.

TPaletteAxis

A `TPaletteAxis` object is used to display the color palette when drawing 2D histograms. The object is automatically created when drawing a 2D histogram when the option "z" is specified. It is added to the histogram list of functions. It can be retrieved and its attributes can be changed with:

```
TPaletteAxis *palette=(TPaletteAxis*)h->FindObject("palette");
```

The palette can be interactively moved and resized. The context menu can be used to set the axis attributes. It is possible to select a range on the axis, to set the min/max in z.

Drawing a Sub-range of a 2-D Histogram (the [cutg] Option)

Using a `TCutG` object, it is possible to draw a 2D histogram sub-range. One must create a graphical cut (mouse or C++) and specify the name of the cut between `[]` in the Draw option. For example, with a `TCutG` named "cutg", one can call:

```
myhist->Draw("surf1 [cutg]");
```

Or, assuming two graphical cuts with name "cut1" and "cut2", one can do:

```
h1.Draw("lego");  
h2.Draw("[cut1,-cut2],surf,same");
```

The second Draw will superimpose on top of the first lego plot a subset of h2 using the "surf" option with:

- all the bins inside cut1
- all the bins outside cut2

Up to 16 cuts may be specified in the cut string delimited by "[. .]". Currently only the following drawing options are sensitive to the cuts option: `col`, `box`, `scat`, `hist`, `lego`, `surf` and cartesian coordinates only.

See a complete example in the tutorial `$ROOTSYS/tutorials/fit2a.C`. This tutorial produces the following picture:

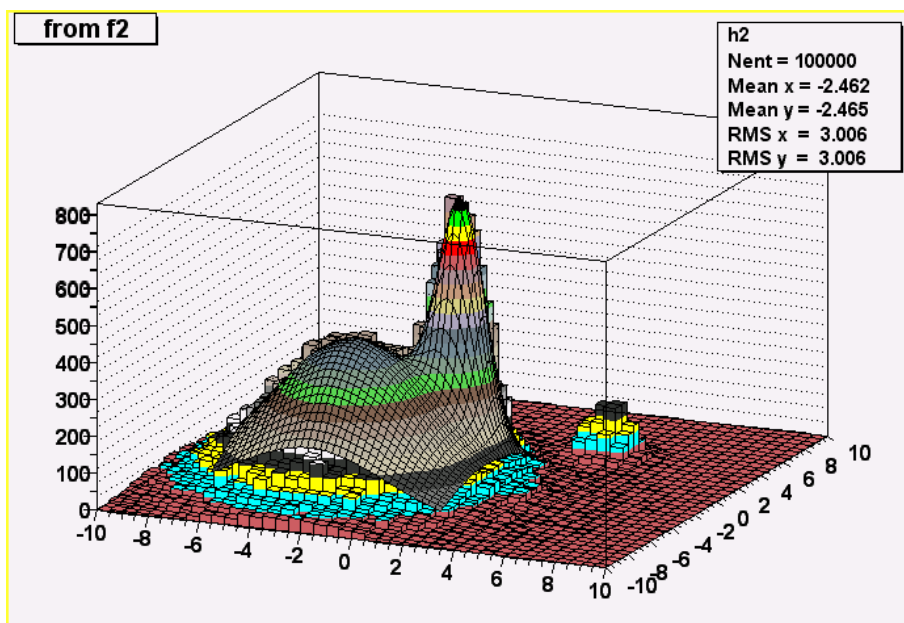

Drawing Options for 3-D Histograms

By default a 3D scatter plot is drawn. If the "BOX" option is specified, a 3D box with a volume proportional to the cell content is drawn.

Superimposing Histograms with Different Scales

The following script creates two histograms; the second histogram is the bins integral of the first one. It shows a procedure to draw the two histograms in the same pad and it draws the scale of the second histogram using a new vertical axis on the right side.

```

void twoscales() {
    TCanvas *c1 = new TCanvas("c1","different scales hist",600,400);

    //create, fill and draw h1
    gStyle->SetOptStat(kFALSE);
    TH1F *h1 = new TH1F("h1","my histogram",100,-3,3);
    Int_t i;
    for (i=0;i<10000;i++) h1->Fill(gRandom->Gaus(0,1));
    h1->Draw();
    c1->Update();
    //create hint1 filled with the bins integral of h1
    TH1F *hint1 = new TH1F("hint1","h1 bins integral",100,-3,3);
    Float_t sum = 0;
    for (i=1;i<=100;i++) {
        sum += h1->GetBinContent(i);
        hint1->SetBinContent(i,sum);
    }
    //scale hint1 to the pad coordinates
    Float_t rightmax = 1.1*hint1->GetMaximum();
    Float_t scale = gPad->GetYmax()/rightmax;
    hint1->SetLineColor(kRed);
    hint1->Scale(scale);
    hint1->Draw("same");
    //draw an axis on the right side
    TGaxis *axis = new TGaxis(gPad->GetXmax(),gPad->GetYmin(),
        gPad->GetXmax(), gPad->GetYmax(),0,rightmax,510,"+L");
    axis->SetLineColor(kRed);
    axis->SetLabelColor(kRed);
    axis->Draw();
}

```

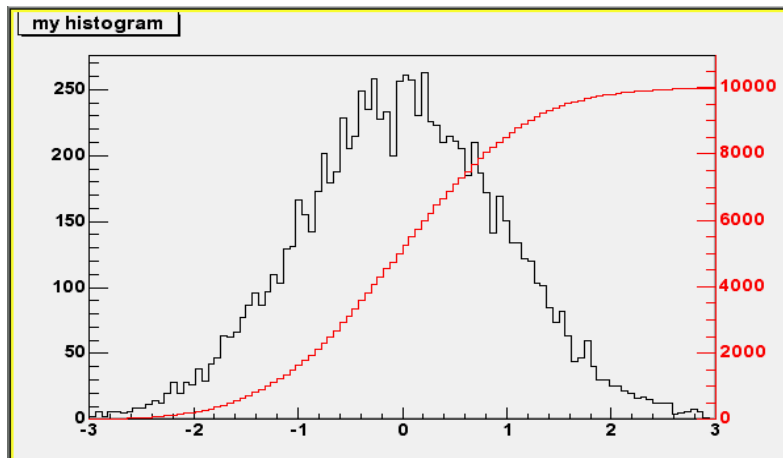

Making a Copy of an Histogram

Like for any other ROOT object derived from `TObject`, one can use the `Clone` method. This makes an identical copy of the original histogram including all associated errors and functions:

```

TH1F *hnew = (TH1F*)h->Clone();
hnew->SetName("hnew");
// renaming is recommended, because otherwise you will
// have two histograms with the same name

```

Normalizing Histograms

You can scale a histogram (**TH1** *h) such that the bins integral is equal to the normalization parameter norm with:

```
Double_t scale = norm/h->Integral();
h->Scale(scale);
```

Saving/Reading Histograms to/from a File

The following statements create a ROOT file and store a histogram on the file. Because **TH1** derives from **TNamed**, the key identifier on the file is the histogram name:

```
TFile f("histos.root","new");
TH1F h1("hgaus","histo from a gaussian",100,-3,3);
h1.FillRandom("gaus",10000);
h1->Write();
```

To read this histogram in another ROOT session, do:

```
TFile f("histos.root");
TH1F *h = (TH1F*)f.Get("hgaus");
```

One can save all histograms in memory to the file by:

```
file->Write();
```

For a more detailed explanation, see chapter [Input/Output](#).

Miscellaneous Operations

- **TH1::KolmogorovTest**(**TH1** *h2, **Option_t** *option) is statistical test of compatibility in shape between two histograms. The parameter `option` is a character string that specifies options
 - "U" include Underflows in test (also for 2-dim)
 - "O" include Overflows (also valid for 2-dim)
 - "N" include comparison of normalizations
 - "D" put out a line of "Debug" printout
 - "M" return the maximum Kolmogorov distance instead of `prob`
 - "X" run the pseudo experiments post-processor with the following procedure: it makes pseudo experiments based on random values from the parent distribution and compare the `KS` distance of the pseudo experiment to the parent distribution. Bin the `KS` distances in a histogram, and then take the integral of all the `KS` values above the value obtained from the original data to Monte Carlo distribution. The number of pseudo-experiments `NEXPT` is currently fixed at 1000. The function returns the integral. Note that this option "X" is much slower.
- **TH1::Smooth** - it smoothes the bin contents of a 1D histogram
- **TH1::Integral**: returns the integral of bin contents in a given bin range
- **TH1::GetMean**(`int axis`): returns the mean value along axis
- **TH1::GetRMS**(`int axis`): returns the Root Mean Square along axis
- **TH1::GetEntries**(): returns the number of entries
- **TH1::GetAsymmetry**(**TH1** *h2, **Double_t** c2, **Double_t** dc2) : returns an histogram containing the asymmetry of `this` histogram with `h2`, where the asymmetry is defined as:

```
Asymmetry = (h1 - h2)/(h1 + h2) //where h1 = this
```

It works for 1D, 2D, etc. histograms. The parameter *c2* is an optional argument that gives a relative weight between the two histograms, and *c2* is the error on this weight. This is useful, for example, when forming an asymmetry between two histograms from two different data sets that need to be normalized to each other in some way. The function calculates the errors assuming Poisson statistics on *h1* and *h2* (that is, $dh = \sqrt{h}$). Here is an example: assuming *h1* and *h2* are already filled:

```
h3 = h1->GetAsymmetry(h2)
```

then *h3* is created and filled with the asymmetry between *h1* and *h2*; *h1* and *h2* are left intact. Note that the user's responsibility is to ménage the created histograms.

- **TH1::Reset()** : resets the bin contents and errors of a histogram

Alphanumeric Bin Labels

By default, a histogram axis is drawn with its numeric bin labels. One can specify alphanumeric labels instead.

Option 1: SetBinLabel

To set an alphanumeric bin label call:

```
TAxis::SetBinLabel(bin, label);
```

This can always be done before or after filling. When the histogram is drawn, bin labels will be automatically drawn.

Option 2: Fill

You can also call a **Fill** function with one of the arguments being a string:

```
hist1->Fill(somename, weight);
hist2->Fill(x, somename, weight);
hist2->Fill(somename, y, weight);
hist2->Fill(somename, somenamey, weight);
```

See example in \$ROOTSYS/tutorials/hlabels1.C, hlabels2.C.

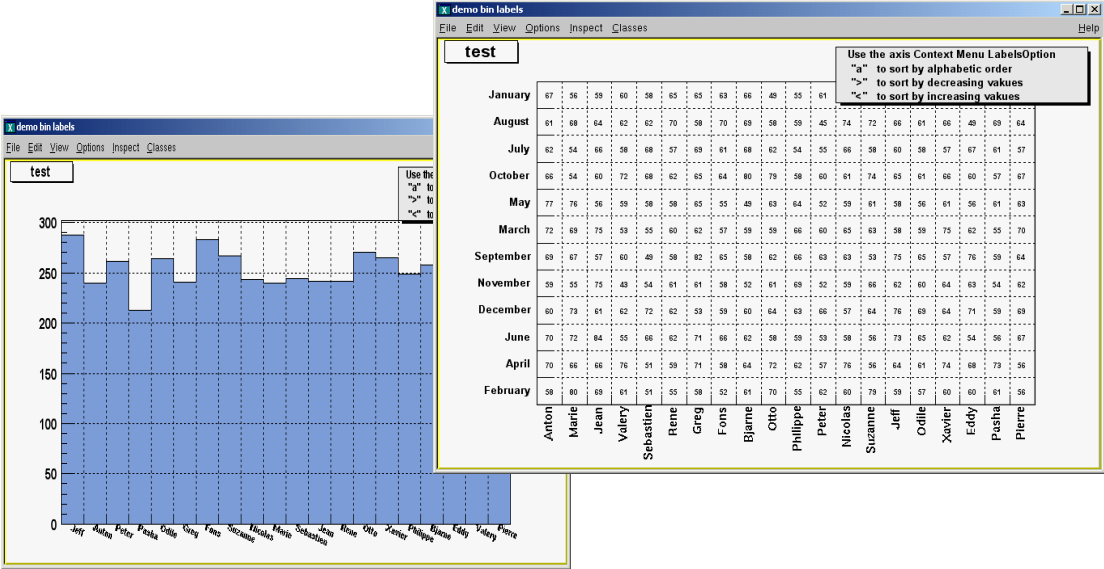

Option 3: TTree::Draw

You can use a char* variable type to histogram strings with **TTree::Draw**.

```
tree.Draw("Nation::Division");  
// where "Nation" and "Division" are two char* branches of a Tree
```

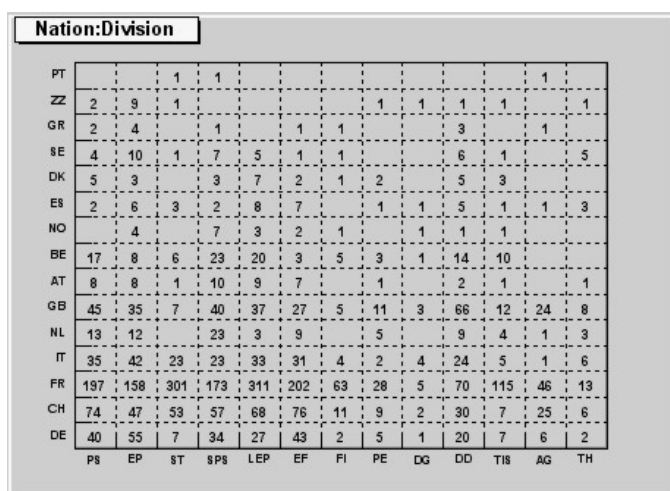

There is an example in \$ROOTSYS/tutorials/cernstaff.C.

If a variable is defined as char* it is drawn as a string by default. You change that and draw the value of char[0] as an integer by adding an arithmetic operation to the expression as shown below.

```
tree.Draw("MyChar + 0");  
//this will draw the integer value of MyChar[0] where "MyChar" is char[5]
```

Sort Options

When using the options 2 or 3 above, the labels are automatically added to the list (**THashList**) of labels for a given axis. By default, an axis is drawn with the order of bins corresponding to the filling sequence. It is possible to reorder the axis alphabetically or by increasing or decreasing values. The reordering can be triggered via the **TAxis** context menu by selecting the menu item "LabelsOption" or by calling directly.

```
TH1::LabelsOption(option,axis)
```

Where axis may be "X", "Y" or "Z". The parameter option may be:

- "a" sort by alphabetic order
- ">" sort by decreasing values
- "<" sort by increasing values
- "h" draw labels horizontal
- "v" draw labels vertical
- "u" draw labels up (end of label right adjusted)
- "d" draw labels down (start of label left adjusted)

When using the option 2 above, new labels are added by doubling the current number of bins in case one label does not exist yet. When the Filling is terminated, it is possible to trim the number of bins to match the number of active labels by calling:

```
TH1::LabelsDeflate(axis)
```

Where axis = "X", "Y" or "Z"

This operation is automatic when using **TTree::Draw**. Once bin labels have been created, they become persistent if the histogram is written to a file or when generating the C++ code via **SavePrimitive**.

Histogram Stacks

A **THStack** is a collection of **TH1** (or derived) objects. To add a histogram to the stack, use **THStack::Add(TH1 *h)**. The **THStack** owns the objects in the list.

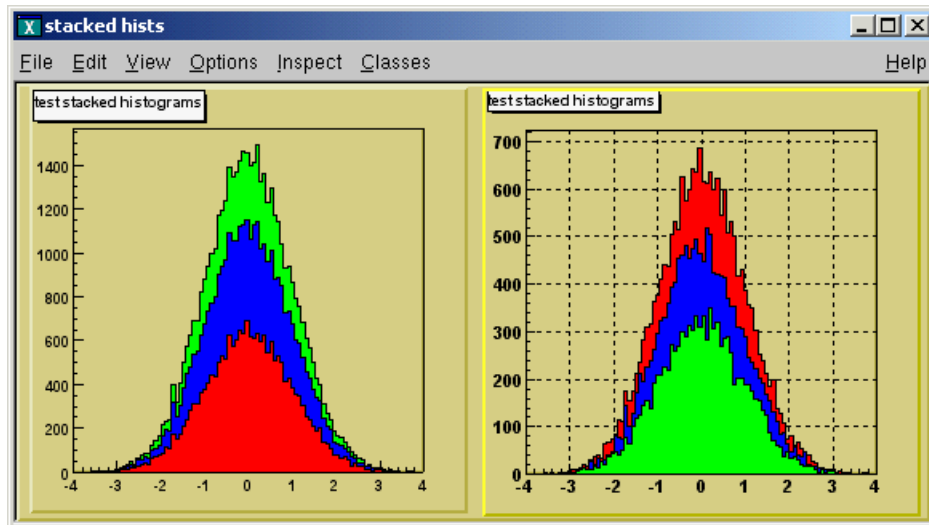

By default, **THStack::Draw** draws the histograms stacked as shown in the left pad in the picture above. If the option "nostack" is used, the histograms are superimposed as if they were drawn one at a time using the "same" draw option. The right pad in the picture above illustrates the **THStack** drawn with the "nostack" option.

```
hs->Draw("nostack");
```

THStack Example

Next is a simple example, for a more complex example see [\\$ROOTSYS/tutorials/hstack.C](#).

```
{
  THStack hs("hs","test stacked histograms");
  TH1F *h1 = new TH1F("h1","test hstack",100,-4,4);
  h1->FillRandom("gaus",20000);
  h1->SetFillColor(kRed);
  hs.Add(h1);

  TH1F *h2 = new TH1F("h2","test hstack",100,-4,4);
  h2->FillRandom("gaus",15000);
  h2->SetFillColor(kBlue);
  hs.Add(h2);

  TH1F *h3 = new TH1F("h3","test hstack",100,-4,4);
  h3->FillRandom("gaus",10000);
  h3->SetFillColor(kGreen);
  hs.Add(h3);

  TCanvas c1("c1","stacked hists",10,10,700,900);
  c1.Divide(1,2);
  c1.cd(1);
  hs.Draw();
  c1.cd(2);
  hs->Draw("nostack");
}
```

Profile Histograms

Profile histograms are in many cases an elegant replacement of two-dimensional histograms. The relationship of two quantities X and Y can be visualized by a two-dimensional histogram or a scatter-plot; its representation is not particularly satisfactory, except for sparse data. If Y is an unknown [but single-valued] function of X, it can be displayed by a profile histogram with much better precision than by a scatter-plot. Profile histograms display the mean value of Y and its RMS for each bin in X.

The following shows the contents [capital letters] and the values shown in the graphics [small letters] of the elements for bin j.

When you fill a profile histogram with `TProfile.Fill[x,y]`:

`H[j]` will contain for each bin j the sum of the y values for this bin

`L[j]` contains the number of entries in the bin j.

`e[j]` or `s[j]` will be the resulting error depending on the selected option described in Build Options below.

$$\begin{aligned} E[j] &= \text{sum } Y^{**2} \\ L[j] &= \text{number of entries in bin } J \\ H[j] &= \text{sum } Y \\ \\ h[j] &= H[j] / L[j] \\ s[j] &= \text{sqrt}[E[j] / L[j] - h[j]**2] \\ e[j] &= s[j] / \text{sqrt}[L[j]] \end{aligned}$$

In the special case where `s[j]` is zero, when there is only one entry per bin, `e[j]` is computed from the average of the `s[j]` for all bins. This approximation is used to keep the bin during a fit operation.

The TProfile Constructor

The `TProfile` constructor takes up to six arguments. The first five parameters are similar to `TH1D::TH1D`.

```
TProfile(const char *name, const char *title, Int_t nbins,
        Axis_t xlow, Axis_t xup, Option_t *option)
```

The first five parameters are similar to `TH1D::TH1D`. All values of y are accepted at filling time. To fill a profile histogram, you must use `TProfile::Fill` function.

Note that when filling the profile histogram the method `TProfile::Fill` checks if the variable y is between `fYmin` and `fYmax`. If a minimum or maximum value is set for the Y scale before filling, then all values below `ymin` or above `ymax` will be discarded. Setting the minimum or maximum value for the Y scale before filling has the same effect as calling the special `TProfile` constructor above where `ymin` and `ymax` are specified.

Build Options

The last parameter is the build option. If a bin has N data points all with the same value Y, which is the case when dealing with integers, the spread in Y for that bin is zero, and the uncertainty assigned is also zero, and the bin is ignored in making subsequent fits. If $\text{SQRT}(Y)$ was the correct error in the case above, then $\text{SQRT}(Y) / \text{SQRT}(N)$ would be the correct error here. In fact, any bin with non-zero number of entries N but with zero spread (`spread = s[j]`) should have an uncertainty $\text{SQRT}(Y) / \text{SQRT}(N)$.

Now, is $\text{SQRT}(Y) / \text{SQRT}(N)$ really the correct uncertainty? That it is only in the case where the Y variable is some sort of counting statistics, following a Poisson distribution. This is the default case. However, Y can be any variable from an original `NTUPLE`, and does not necessarily follow a Poisson distribution.

The computation of errors is based on the parameter option:

Y = values of data points; N = number of data points

' ' The default is blank, the Errors are:

spread/SQRT (N)	for a non-zero spread
SQRT (Y) /SQRT (N)	for a spread of zero and some data points
0	for no data points

's' Errors are:

spread	for a non-zero spread
SQRT (Y)	for a Spread of zero and some data points
0	for no data points

'i' Errors are:

spread/SQRT (N)	for a non-zero spread
1/SQRT (12*N)	for a Spread of zero and some data points
0	for no data points

'G' Errors are:

spread/SQRT (N)	for a non-zero spread
sigma/SQRT (N)	for a spread of zero and some data points
0	for no data points

The third case (option 'i') is used for integer Y values with the uncertainty of ± 0.5 , assuming the probability that Y takes any value between Y-0.5 and Y+0.5 is uniform (the same argument for Y uniformly distributed between Y and Y+1). An example is an ADC measurement.

The 'G' option is useful, if all Y variables are distributed according to some known Gaussian of standard deviation Sigma. For example when all Y's are experimental quantities measured with the same instrument with precision Sigma.

Example of a TProfile

Here is the graphic output of a simple example of a profile histogram:

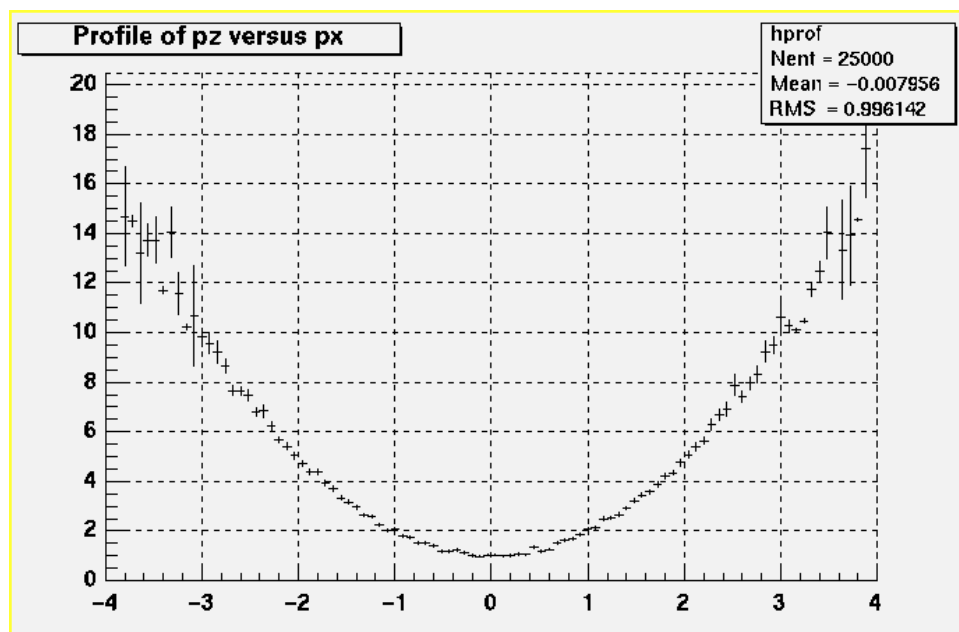

```

{
  // Create a canvas giving the coordinates and the size
  TCanvas *c1 = new TCanvas("c1","Profile example",200,10,700,500);

  // Create a profile with the name, title, the number of bins, the
  // low and high limit of the x-axis and the low and high limit
  // of the y-axis. No option is given so the default is used.
  hprof = new TProfile("hprof","Profile of pz versus px",100,-4,4,0,20);

  // Fill the profile 25000 times with random numbers
  Float_t px, py, pz;
  for ( Int_t i=0; i<25000; i++) {

    // Use the random number generator to get two numbers following a
    //gaussian distribution with mean=0 and sigma=1
    gRandom->Rannor(px,py);
    pz = px*px + py*py;
    hprof->Fill(px,pz,1);
  }
  hprof->Draw();
}

```

Drawing a Profile without Error Bars

To draw a profile histogram and not show the error bars use the "HIST" option in the **TProfile::Draw** method. This will draw the outline of the **TProfile**.

Create a Profile from a 2D Histogram

You can make a profile from a histogram using the methods **TH2::ProfileX** and **TH2::ProfileY**.

Create a Histogram from a Profile

To create a regular histogram from a profile histogram, use the method **TProfile::ProjectionX**.

This example instantiates a **TH1D** object by copying the **TH1D** piece of **TProfile**.

```
TH1D *sum = myProfile.ProjectionX()
```

You can do the same with a 2D profile using the method **TProfile2D::ProjectionXY**.

Generating a Profile from a TTree

The 'prof' and 'profs' options in the **TTree::Draw** method (see the chapter on [Trees](#)) generate a profile histogram (**TProfile**), given a two dimensional expression in the tree, or a **TProfile2D** given a three dimensional expression. Note that you can specify 'prof' or 'profs': 'prof' generates a **TProfile** with error on the mean, 'profs' generates a **TProfile** with error on the spread,

2D Profiles

The class for a 2D Profile is called **TProfile2D**. It is in many cases an elegant replacement of a three-dimensional histogram. The relationship of three measured quantities X, Y and Z can be visualized by a three-dimensional histogram or scatter-plot; its representation is not particularly satisfactory, except for sparse data. If Z is an unknown (but single-valued) function of (X,Y), it can be displayed with a **TProfile2D** with better precision than by a scatter-plot. A **TProfile2D** displays the mean value of Z and its RMS for

each cell in X,Y. The following shows the cumulated contents (capital letters) and the values displayed (small letters) of the elements for cell I, J.

When you fill a profile histogram with `TProfile2D.Fill[x,y,z]`:

$E[i,j]$ contains for each bin i,j the sum of the z values for this bin

$L[i,j]$ contains the number of entries in the bin j

$e[j]$ or $s[j]$ will be the resulting error depending on the selected option described in Build Options above.

$$\begin{aligned} E[i,j] &= \text{sum } z \\ L[i,j] &= \text{sum } l \\ h[i,j] &= H[i,j] / L[i,j] \\ s[i,j] &= \sqrt{E[i,j] / L[i,j] - h[i,j]**2} \\ e[i,j] &= s[i,j] / \sqrt{L[i,j]} \end{aligned}$$

In the special case where $s[i,j]$ is zero, when there is only one entry per cell, $e[i,j]$ is computed from the average of the $s[i,j]$ for all cells. This approximation is used to keep the cell during a fit operation.

Example of a TProfile2D Histogram

```
{
// Creating a Canvas and a TProfile2D
TCanvas *c1 = new TCanvas("c1","Profile histogram example",
                        200,10,700,500);
hprof2d = new TProfile2D("hprof2d","Profile of pz versus px and py",
                        40,-4,4,40,-4,4,0,20);

// Filling the TProfile2D with 25000 points
Float_t px, py, pz;
for ( Int_t i=0; i<25000; i++) {
    gRandom->Rannor(px,py);
    pz = px*px + py*py;
    hprof2d->Fill(px,py,pz,1);
}
hprof2d->Draw();
}
```

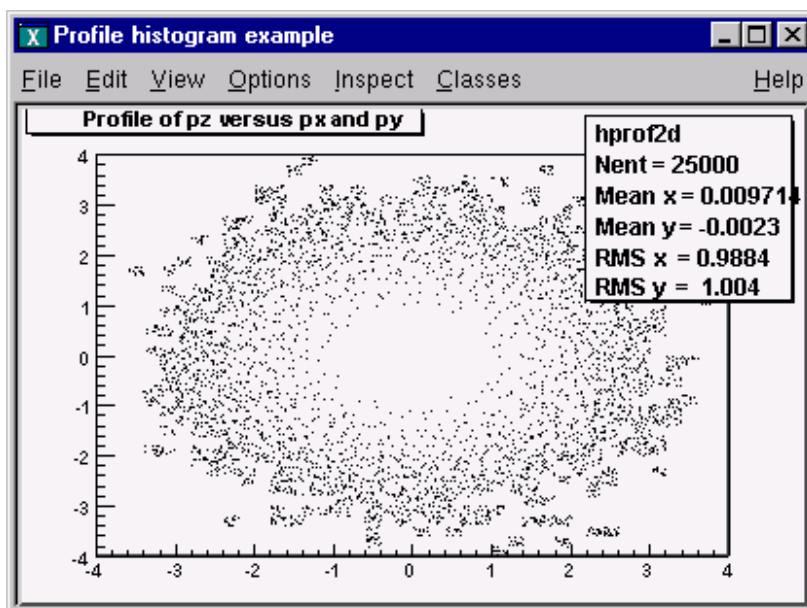

4 Graphs

A graph is a graphics object made of two arrays X and Y, holding the x, y coordinates of n points. There are several graph classes, they are: **TGraph**, **TGraphErrors**, **TGraphAsymmErrors**, and **TMultiGraph**.

TGraph

The **TGraph** class supports the general case with non equidistant points, and the special case with equidistant points.

Creating Graphs

Graphs are created with the constructor. Here is an example. First we define the arrays of coordinates and then create the graph. The coordinates can be arrays of doubles or floats.

```
Int_t n = 20;
Double_t x[n], y[n];

for (Int_t i=0; i<n; i++) {
    x[i] = i*0.1;
    y[i] = 10*sin(x[i]+0.2);
}
TGraph *gr1 = new TGraph (n, x, y);
```

An alternative constructor takes only the number of points (n). It is expected that the coordinates will be set later.

```
TGraph *gr2 = new TGraph(n);
```

Graph Draw Options

The various draw options for a graph are explained in **TGraph::PaintGraph**. They are:

- "L" A simple poly-line between every points is drawn
- "F" A fill area is drawn
- "A" Axis are drawn around the graph
- "C" A smooth curve is drawn
- "*" A star is plotted at each point
- "P" The current marker of the graph is plotted at each point
- "B" A bar chart is drawn at each point
- "[]" Only the end vertical/horizontal lines of the error bars are drawn. This option only applies to the **TGraphAsymmErrors**.

The options are not case sensitive and they can be concatenated in most cases. Let's look at some examples.

Continuous Line, Axis and Stars (AC*)

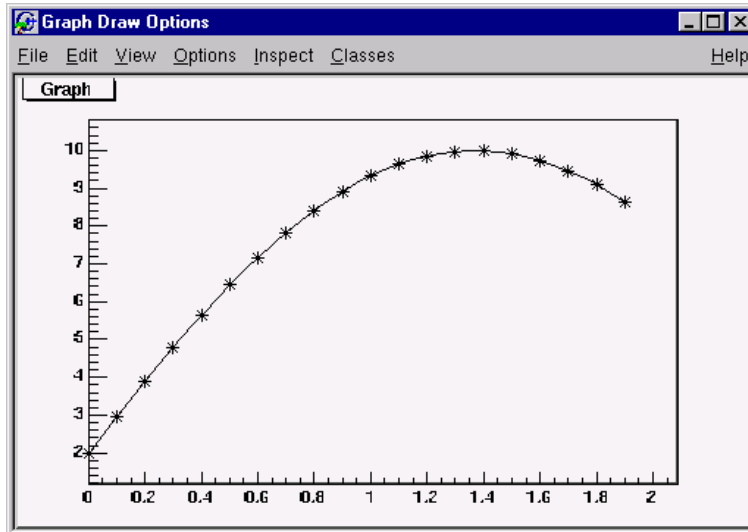

```
{
  Int_t n = 20;
  Double_t x[n], y[n];

  for (Int_t i=0;i<n;i++) {
    x[i] = i*0.1;
    y[i] = 10*sin(x[i]+0.2);
  }

  // create graph
  TGraph *gr = new TGraph(n,x,y);
  TCanvas *c1 = new TCanvas("c1","Graph Draw Options",200,10,600,400);

  // draw the graph with axis,contineous line, and put a * at each point
  gr->Draw("AC*");
}
```

Bar Graphs (AB)

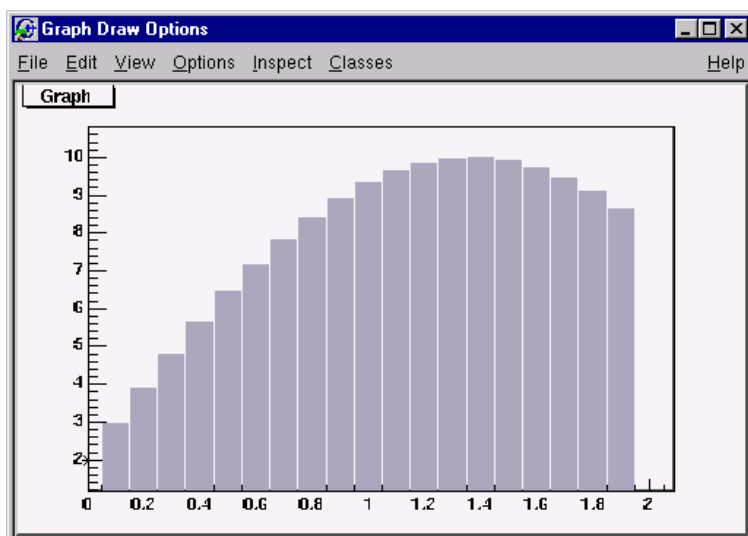

```

root[] TGraph *gr1 = new TGraph(n,x,y);
root[] gr1->SetFillColor(40);
root[] gr1->Draw("AB");

```

This code will only work if n, x, and y is defined. The previous example defines these. You need to set the fill color, because by default the fill color is white and will not be visible on a white canvas. You also need to give it an axis, or the bar chart will not be displayed properly.

Filled Graphs (AF)

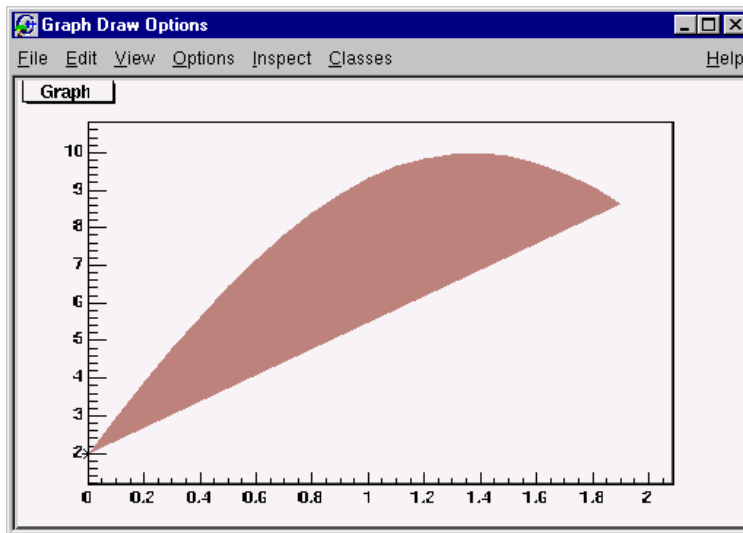

```

root[] TGraph *gr3 = new TGraph(n,x,y);
root[] gr3->SetFillColor(45);
root[] gr3->Draw("AF")

```

This code will only work if n, x, y are defined. The first example defines them. You need to set the fill color, because by default the fill color is white and will not be visible on a white canvas. You also need to give it an axis, or the bar chart will not be displayed properly. Currently one can not specify the "CF" option.

Marker Options

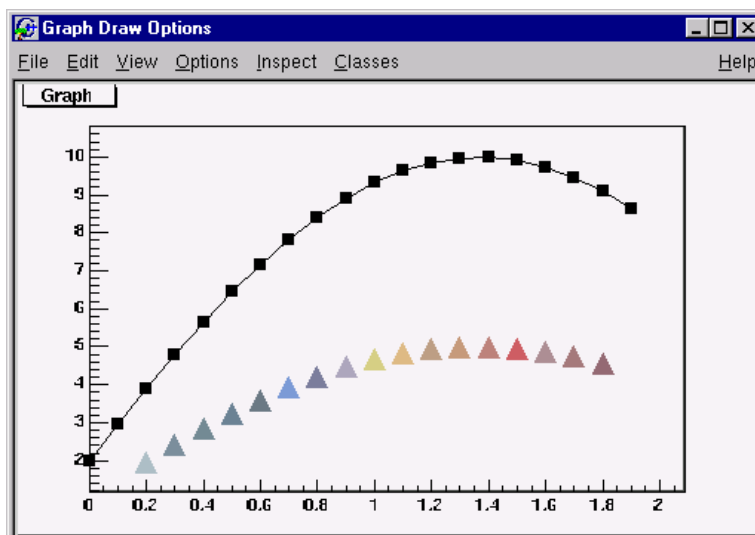

```

{
  Int_t n = 20;
  Double_t x[n], y[n];

  // build the arrays with the coordinate of points
  for (Int_t i=0; i<n; i++) {
    x[i] = i*0.1;
    y[i] = 10*sin(x[i]+0.2);
  }

  // create graphs
  TGraph *gr3 = new TGraph(n,x,y);

  TCanvas *c1 = new TCanvas ("c1","Graph Draw Options",200,10,600,400);

  // draw the graph with the axis,contineous line, and put
  // a marker using the graph's marker style at each point
  gr3->SetMarkerStyle(21);
  c1->cd(4);
  gr3->Draw("APL");

  // get the points in the graph and put them into an array
  Double_t *nx = gr3->GetX();
  Double_t *ny = gr3->GetY();

  // create markers of different colors
  for (Int_t j=2; j<n-1; j++) {
    TMarker *m = new TMarker(nx[j], 0.5*ny[j], 22);
    m->SetMarkerSize(2);
    m->SetMarkerColor(31+j);
    m->Draw();
  }
}

```

Superimposing Two Graphs

To super impose two graphs you need to draw the axis only once, and leave out the "A" in the draw options for the second graph. Here is an example:

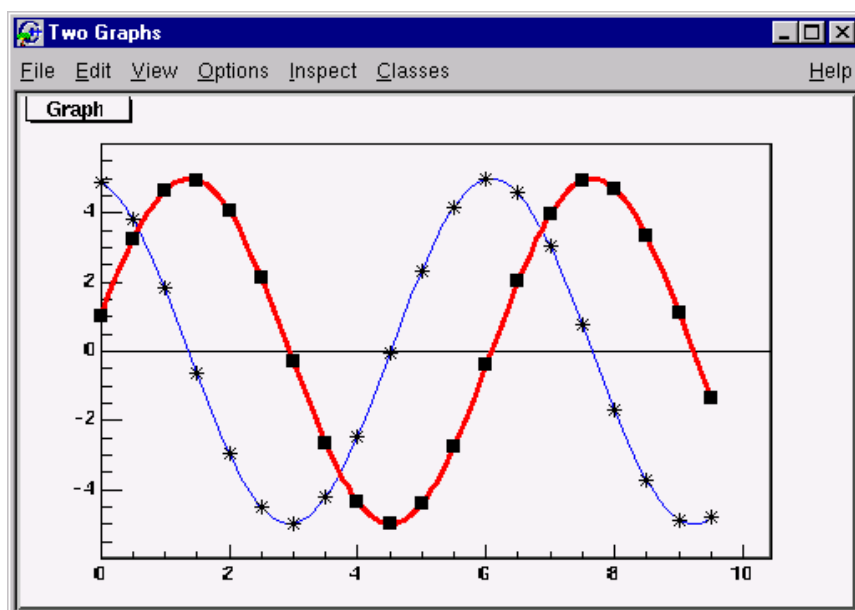

```

{
gROOT->Reset();
Int_t n = 20;
Double_t x[n], y[n], x1[n], y1[n];

// create the blue graph with a cos function
for (Int_t i=0; i<n; i++) {
    x[i] = i*0.5;
    y[i] = 5*cos(x[i]+0.2);
    x1[i] = i*0.5;
    y1[i] = 5*sin(x[i]+0.2);
}

TGraph *gr1 = new TGraph(n,x,y);
TGraph *gr2 = new TGraph(n,x1,y1);

TCanvas *c1 = new TCanvas("c1","Two Graphs",200,10,600,400);

// draw the graph with axis,contineous line, and put a * at each point
gr1->SetLineColor(4);
gr1->Draw("AC*");

// superimpose the second graph by leaving out the axis option "A"
gr2->SetLineWidth(3);
gr2->SetMarkerStyle(21);
gr2->SetLineColor(2);
gr2->Draw("CP");
}

```

TGraphErrors

A **TGraphErrors** is a **TGraph** with error bars. The various draw format options of **TGraphErrors::Paint** are derived from **TGraph**.

```
void TGraphErrors::Paint(Option_t *option)
```

In addition, it can be drawn with the "Z" option to leave off the small lines at the end of the error bars. If option contains ">" an arrow is drawn at the end of the error bars if option contains "|>" a full arrow is drawn at the end of the error bars the size of the arrow is set to 2/3 of the marker size.

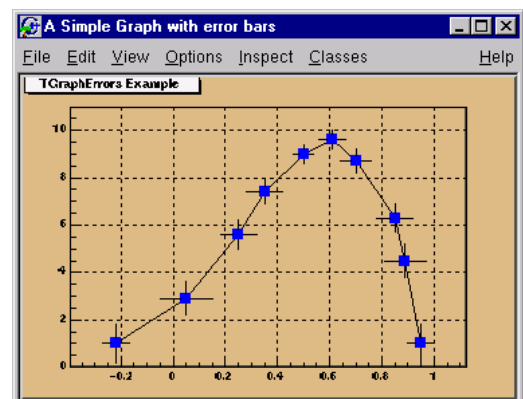
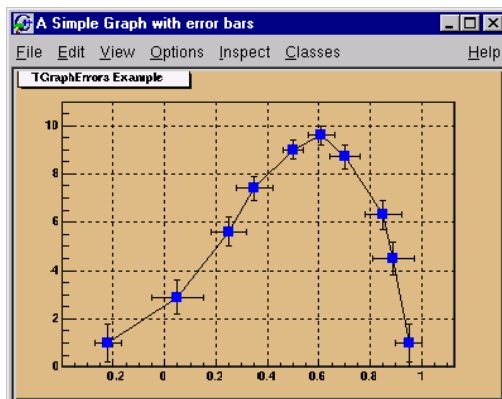

The option "[Z]" is interesting to superimpose systematic errors on top of the graph with the statistical errors. When it is specified only the end vertical/horizontal lines of the error bars are drawn. To control the size of the error along x use:

```
gStyle->SetErrorX(dx);
```

Set dx=0 to suppress the error along x.

Use:

```
gStyle->SetEndErrorSize(np);
```

to control the size of the lines at the end of the error bars (when option 1 is used). By default `np=1`; `np` represents the number of pixels.

The constructor has four arrays as parameters. X and Y as in **TGraph** and X-errors and Y-errors the size of the errors in the x and y direction. This example is in `$ROOTSYS/tutorials/gerrors.C`.

```
{
  gROOT->Reset();

  c1 = new TCanvas("c1", "A Simple Graph with error bars", 200, 10, 700, 500);

  c1->SetFillColor(42);
  c1->SetGrid();
  c1->GetFrame()->SetFillColor(21);
  c1->GetFrame()->SetBorderSize(12);

  // create the coordinate arrays
  Int_t n = 10;
  Float_t x[n] = {-.22, .05, .25, .35, .5, .61, .7, .85, .89, .95};
  Float_t y[n] = {1, 2.9, 5.6, 7.4, 9, 9.6, 8.7, 6.3, 4.5, 1};

  // create the error arrays
  Float_t ex[n] = {.05, .1, .07, .07, .04, .05, .06, .07, .08, .05};
  Float_t ey[n] = {.8, .7, .6, .5, .4, .4, .5, .6, .7, .8};

  // create the TGraphErrors and draw it
  gr = new TGraphErrors(n, x, y, ex, ey);
  gr->SetTitle("TGraphErrors Example");
  gr->SetMarkerColor(4);
  gr->SetMarkerStyle(21);
  gr->Draw("ALP");

  c1->Update();
}
```

TGraphAsymmErrors

A **TGraphAsymmErrors** is a **TGraph** with asymmetric error bars. It inherits the various draw format options from **TGraph**. Its method `Paint(Option_t *option)` paints the **TGraphAsymmErrors** with the current attributes.

You can set the following additional options for drawing:

- "z" or "Z" the horizontal and vertical small lines are not drawn at the end of error bars
- ">" an arrow is drawn at the end of the error bars
- "|>" a full arrow is drawn at the end of the error bar; its size is 2/3 of the marker size
- "[]" only the end vertical/horizontal lines of the error bars are drawn; this option is interesting to superimpose systematic errors on top of a graph with statistical errors.

The constructor has six arrays as parameters: X and Y as **TGraph** and low X-errors and high X-errors, low Y-errors and high Y-errors. The low value is the length of the error bar to the left and down, the high value is the length of the error bar to the right and up.

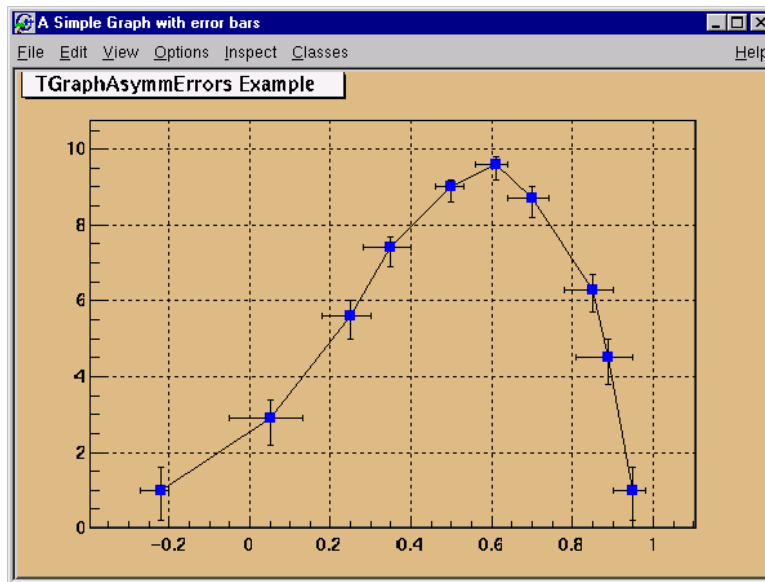

```

{
  gROOT->Reset();
  c1 = new TCanvas("c1","A Simple Graph with error bars",
                  200,10,700,500);

  c1->SetFillColor(42);
  c1->SetGrid();
  c1->GetFrame()->SetFillColor(21);
  c1->GetFrame()->SetBorderSize(12);

  // create the arrays for the points
  Int_t n = 10;
  Double_t x[n] = {-.22,.05,.25,.35,.5, .61,.7,.85,.89,.95};
  Double_t y[n] = {1,2.9,5.6,7.4,9,9.6,8.7,6.3,4.5,1};

  // create the arrays with high and low errors
  Double_t exl[n] = {.05,.1,.07,.07,.04,.05,.06,.07,.08,.05};
  Double_t eyl[n] = {.8,.7,.6,.5,.4,.4,.5,.6,.7,.8};
  Double_t exh[n] = {.02,.08,.05,.05,.03,.03,.04,.05,.06,.03};
  Double_t eyh[n] = {.6,.5,.4,.3,.2,.2,.3,.4,.5,.6};

  // create TGraphAsymmErrors with the arrays
  gr = new TGraphAsymmErrors(n,x,y,exl,exh,eyl,eyh);
  gr->SetTitle("TGraphAsymmErrors Example");
  gr->SetMarkerColor(4);
  gr->SetMarkerStyle(21);
  gr->Draw("ALP");
}

```

TMultiGraph

A **TMultiGraph** is a collection of **TGraph** (or derived) objects. Use **TMultiGraph::Add** to add a new graph to the list. The **TMultiGraph** owns the objects in the list. The drawing options are the same as for **TGraph**.

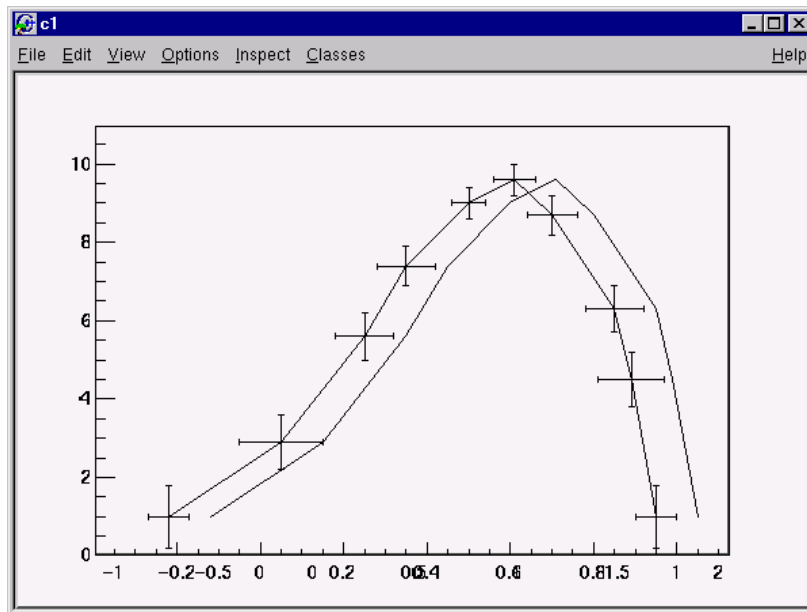

```

{
    // create the points
    Int_t n = 10;
    Double_t x[n] = {-.22, .05, .25, .35, .5, .61, .7, .85, .89, .95};
    Double_t y[n] = {1, 2.9, 5.6, 7.4, 9, 9.6, 8.7, 6.3, 4.5, 1};

    Double_t x2[n] = {-.12, .15, .35, .45, .6, .71, .8, .95, .99, 1.05};
    Double_t y2[n] = {1, 2.9, 5.6, 7.4, 9, 9.6, 8.7, 6.3, 4.5, 1};

    // create the width of errors in x and y direction
    Double_t ex[n] = {.05, .1, .07, .07, .04, .05, .06, .07, .08, .05};
    Double_t ey[n] = {.8, .7, .6, .5, .4, .4, .5, .6, .7, .8};

    // create two graphs
    TGraph *gr1 = new TGraph(n, x2, y2);
    TGraphErrors *gr2 = new TGraphErrors(n, x, y, ex, ey);

    // create a multigraph and draw it
    TMultiGraph *mg = new TMultiGraph();
    mg->Add(gr1);
    mg->Add(gr2);
    mg->Draw("ALP");
}

```

Fitting a Graph

The `Fit` method of the graph works the same as the `TH1::Fit` (see Fitting Histograms).

Setting the Graph's Axis Title

To give the axis of a graph a title you need to draw the graph first, only then does it actually have an axis object. Once drawn, you set the title by getting the axis and calling the `TAxis::SetTitle` method, and if you want to center it you can call the `TAxis::CenterTitle` method.

Assuming that `n`, `x`, and `y` are defined. Next code sets the titles of the `x` and `y` axes.

```

root[] gr5 = new TGraph(n,x,y) ;
root[] gr5->Draw()
<TCanvas::MakeDefCanvas>: created default TCanvas with name c1
root[] gr5->Draw("ALP")
root[] gr5->GetXaxis()->SetTitle("X-Axis")
root[] gr5->GetYaxis()->SetTitle("Y-Axis")
root[] gr5->GetXaxis()->CenterTitle()
root[] gr5->GetYaxis()->CenterTitle()
root[] gr5->Draw("ALP")

```

For more graph examples see: these scripts in the \$ROOTSYS/tutorials directory graph.C, gerrors.C, zdemo.C, and gerrors2.C.

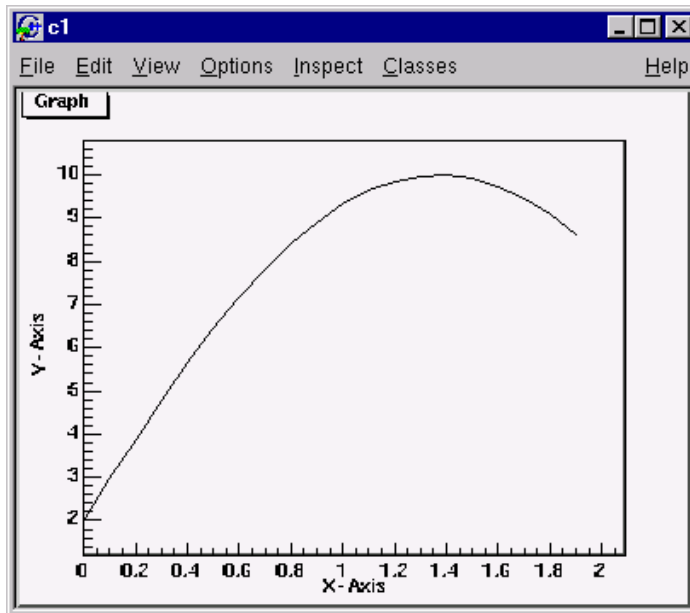

Zooming a Graph

To zoom a graph you can create a histogram with the desired axis range first. Draw the empty histogram and then draw the graph using the existing axis from the histogram.

The next example is the same graph as above with a zoom in the x and y direction.

```

{
gROOT->Reset();
c1 = new TCanvas("c1", "A Zoomed Graph", 200, 10, 700, 500);
// create a histogram for the axis range
hpx = new TH2F("hpx", "Zoomed Graph Example", 10, 0, 0.5, 10, 1.0, 8.0);
// no statistics
hpx->SetStats(kFALSE);
hpx->Draw();

// create a graph
Int_t n = 10;
Double_t x[n] = {-.22, .05, .25, .35, .5, .61, .7, .85, .89, .95};
Double_t y[n] = {1, 2.9, 5.6, 7.4, 9, 9.6, 8.7, 6.3, 4.5, 1};
gr = new TGraph(n, x, y);
gr->SetMarkerColor(4);
gr->SetMarkerStyle(20);

// and draw it without an axis
gr->Draw("LP");
}

```

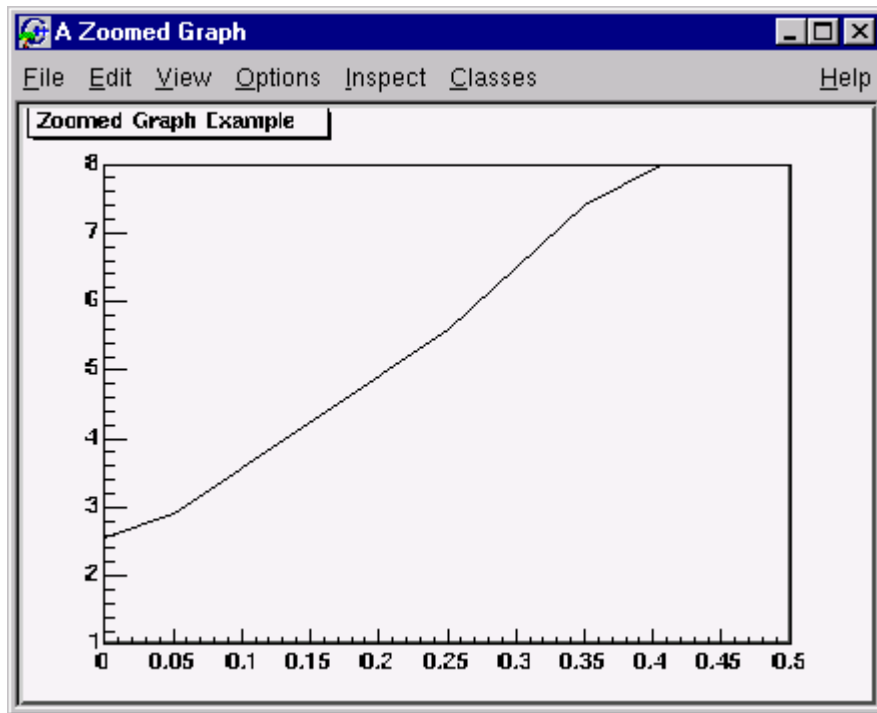

5 Fitting Histograms

To fit a histogram you can use the Fit Panel on a visible histogram using the GUI, or you can use the `TH1 : :Fit` method. The Fit Panel, which is limited, is best for prototyping. The histogram needs to be drawn in a pad before the Fit Panel is available. The `TH1 : :Fit` method is more powerful and used in scripts and programs.

The Fit Panel

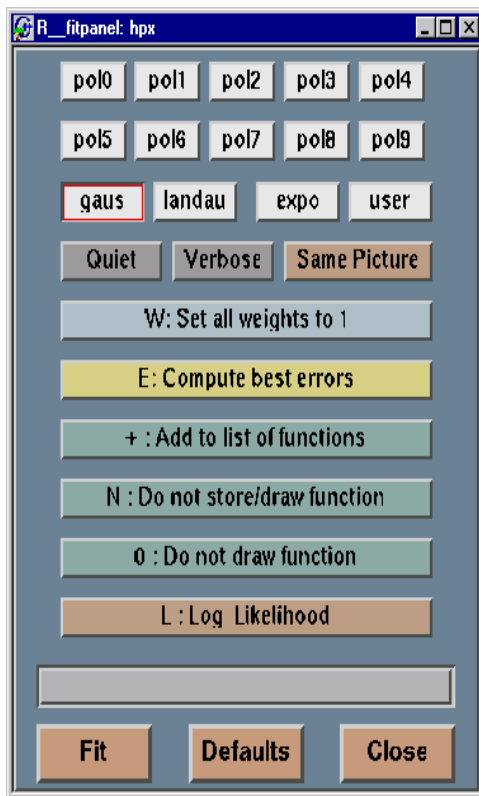

To display the Fit Panel right click on a histogram to bring up the context menu, and then select the menu option: `FitPanel`.

The first sets of buttons are the predefined functions of ROOT that can be used to fit the histogram. You have a choice of several polynomials, a Gaussian, a landau, and an exponential function. You can also define a function and call it "user". It will be linked to the `user` button on this panel.

You have the option to specify `Quiet` or `Verbose`. This is the amount of feedback printed on the root command line on the result of the fit. When a fit is executed the image of the function is drawn on the current pad. By default the image of the histogram is replaced with the image of the function. Select `Same Picture` to see the function drawn and the histogram on the same picture.

Select `W: Set all weights to 1`, to set all errors to 1.

Select `E: Compute best errors` to use the Minos technique to compute best errors.

When fitting a histogram, the function is attached to the histogram's list of functions. By default the previously fitted function is deleted and replaced with the most recent one, so the list only contains one function. You can select `+ : Add to list of functions` to add the newly

fitted function to the existing list of functions for the histogram. Note that the fitted functions are saved with the histogram when it is written to a ROOT file. By default, the function is drawn on the pad displaying the histogram.

Select `N: Do not store/draw function` to avoid adding the function to the histogram and to avoid drawing it.

Select `0: Do not draw function` to avoid drawing the result of the fit.

Select `L: Log Likelihood` to use log likelihood method (default is `chisquare` method).

The slider at the bottom of the panel allows you to set a range for the fit. Drag the edges of the slider towards the center to narrow the range. Draw the entire range to change the beginning and end. To returns to the original setting, you need to press `Defaults`. To apply the fit, press the `Fit` button.

The Fit Method

To fit a histogram programmatically, you can use the `TH1::Fit` method. Here is the signature of `TH1::Fit` and an explanation of the parameters:

```
void Fit(const char *fname ,Option_t *option,
         Option_t *goption,Axis_t xxmin,Axis_t  xxmax)
```

*fname: The name of the fitted function (the model) is passed as the first parameter. This name may be one of ROOT pre-defined function names or a user-defined function.

The following functions are predefined, and can be used with the `TH1::Fit` method.

- `gaus`: A Gaussian function with 3 parameters:
 $f(x) = p_0 \cdot \exp(-0.5 \cdot ((x-p_1)/p_2)^2)$
- `expo`: An exponential with 2 parameters:
 $f(x) = \exp(p_0 + p_1 \cdot x)$.
- `polN`: A polynomial of degree N:
 $f(x) = p_0 + p_1 \cdot x + p_2 \cdot x^2 + \dots$
- `landau`: A Landau function with mean and sigma. This function has been adapted from the CERNLIB routine G110 `denlan`.

*option: The second parameter is the fitting option. Here is the list of fitting options:

- "W" Set all errors to 1
- "I" Use integral of function in bin instead of value at bin center
- "L" Use log likelihood method (default is chi-square method)
- "U" Use a user specified fitting algorithm
- "Q" Quiet mode (minimum printing)
- "V" Verbose mode (default is between Q and V)
- "E" Perform better errors estimation using Minos technique
- "M" Improve fit results
- "R" Use the range specified in the function range
- "N" Do not store the graphics function, do not draw
- "O" Do not plot the result of the fit. By default the fitted function is drawn unless the option "N" above is specified.
- "+" Add this new fitted function to the list of fitted functions (by default, the previous function is deleted and only the last one is kept)
- "B" Disable the automatic computation of the initial parameter values for the standard functions like `poln`, `expo`, and `gaus`.

*goption: Third parameter is the graphics option (`goption`), it is the same as in the `TH1::Draw` (see Draw Options above).

xxmin, xxmax: Fourth and fifth parameters specify the range over which to apply the fit. By default, the fitting function object is added to the histogram and is drawn in the current pad.

Fit with a Predefined Function

To fit a histogram with a predefined function, simply pass the name of the function in the first parameter of `TH1::Fit`. For example, this line fits histogram object `hist` with a Gaussian.

```
root[] hist.Fit("gaus");
```

For pre-defined functions, there is no need to set initial values for the parameters, it is done automatically.

Fit with a User-Defined Function

You can create a **TF1** object and use it in the call the **TH1::Fit**. The parameter in to the **Fit** method is the **NAME** of the **TF1** object.

There are three ways to create a **TF1**.

1. Using C++ like expression using **x** with a fixed set of operators and functions defined in **TFormula**.
2. Same as #1, with parameters
3. Using a function that you have defined

Creating a TF1 with a Formula

Let's look at the first case. Here we call the **TF1** constructor by giving it the formula:
 $\sin(x)/x$.

```
root[] TF1 *f1 = new TF1("f1","sin(x)/x",0,10)
```

You can also use a **TF1** object in the constructor of another **TF1**.

```
root[] TF1 *f2 = new TF1("f2", "f1*2", 0, 10)
```

Creating a TF1 with Parameters

The second way to construct a **TF1** is to add parameters to the expression. For example, this **TF1** has 2 parameters:

```
root[] TF1 *f1 = new TF1("f1", "[0]*x*sin([1]*x)", -3, 3);
```

The parameter index is enclosed in square brackets. To set the initial parameters explicitly you can use the **SetParameter** method.

```
root[] f1->SetParameters(0,10);
```

This sets parameter 0 to 10. You can also use **SetParameters** to set multiple parameters at once.

```
root[] f1->SetParameters(10,5);
```

This sets parameter 0 to 10 and parameter 1 to 5. We can now draw the **TF1**:

```
root[] f1->Draw()
```

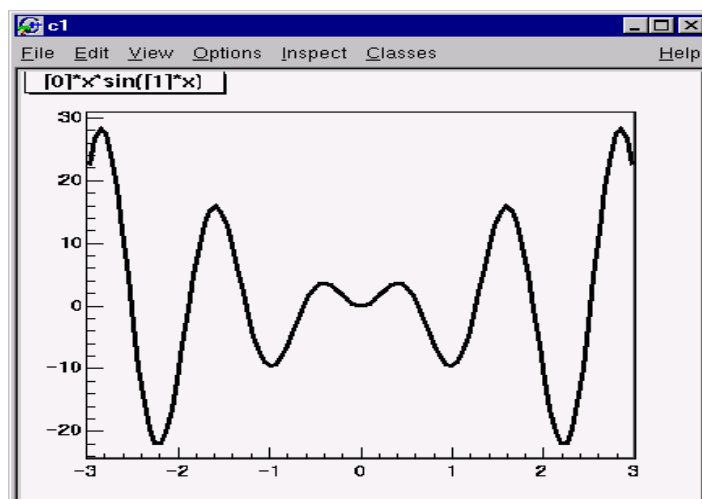

Creating a TF1 with a User Function

The third way to build a **TF1** is to define a function yourself and then give its name to the constructor. A function for a **TF1** constructor needs to have this exact signature:

```
Double_t fitf(Double_t *x, Double_t *par)
```

The two parameters are:

- `Double_t *x`: a pointer to the dimension array. Each element contains a dimension. For a 1D histogram only `x[0]` is used, for a 2D histogram `x[0]` and `x[1]` is used, and for a 3D histogram `x[0]`, `x[1]`, and `x[2]` are used. For histograms, only 3 dimensions apply, but this method is also used to fit other objects, for example an `ntuple` could have 10 dimensions.
- `Double_t *par`: a pointer to the parameters array. This array contains the current values of parameters when it is called by the fitting function.

The following script `$ROOTSYS/tutorials/myfit.C` illustrates how to fit a 1D histogram with a user-defined function. First we declare the function.

```
// define a function with 3 parameters
Double_t fitf(Double_t *x, Double_t *par)
{
    Double_t arg = 0;
    if (par[2] != 0) arg = (x[0] - par[1])/par[2];
    Double_t fitval = par[0]*TMath::Exp(-0.5*arg*arg);
    return fitval;
}
```

Now we use the function:

```
// this function used fitf to fit a histogram
void fitexample()
{
    // open a file and get a histogram
    TFile *f = new TFile("hsimple.root");
    TH1F *hpx = (TH1F*)f->Get(*hpx);

    // Create a TF1 object using the function defined above.
    // The last three parameters specify the number of parameters
    // for the function.
    TF1 *func = new TF1("fit", fitf, -3, 3, 3);

    // set the parameters to the mean and RMS of the histogram
    func->SetParameters(500, hpx->GetMean(), hpx->GetRMS());

    // give the parameters meaningful names
    func->SetParNames("Constant", "Mean_value", "Sigma");

    // call TH1::Fit with the name of the TF1 object
    hpx->Fit("fit");
}
```

Fixing and Setting Bounds for Parameters

Parameters must be initialized before invoking the `Fit` method. The setting of the parameter initial values is automatic for the predefined functions: `poln`, `exp`, `gaus`. You can disable the automatic computation by specifying the "B" option when calling the `Fit` method. When a function is not predefined, the fit parameters must be initialized to some value as close as possible to the expected values before calling the fit function.

To set bounds for one parameter, use `TF1::SetParLimits`:

```
func->SetParLimits(0,-1,1);
```

When the lower and upper limits are equal, the parameter is fixed. This statement fixes parameter 4 at 10.

```
func->SetParameters(4,10)
func->SetParLimits(4,77,77);
```

However, to fix a parameter to 0, one must call the `FixParameter` function:

```
func->SetParameter(4,0)
func->FixParameter(4,0);
```

Note that you are not forced to fix the limits for all parameters. For example, if you fit a function with 6 parameters, you can:

```
func->SetParameters(0,3.1,1.e-6,-1.5,0,100);
func->SetParLimits(3,-10,-4);
func->FixParameter(4,0);
```

With this setup, parameters 0->2 can vary freely, parameter 3 has boundaries [-10,-4] with initial value -8, and parameter 4 is fixed to 0.

Fitting Sub Ranges

By default, `TH1::Fit` will fit the function on the defined histogram range. You can specify the option "R" in the second parameter of `TH1::Fit` to restrict the fit to the range specified in the `TF1` constructor. In this example, the fit will be limited to -3 to 3, the range specified in the `TF1` constructor.

```
root[] TF1 *f1 = new TF1("f1","[0]*x*sin([1]*x",-3,3);
root[] hist->Fit("f1","R");
```

You can also specify a range in the call to `TH1::Fit`:

```
root[] hist->Fit("f1","","",-2,2)
```

For more complete examples, see `$ROOTSYS/tutorials/myfit.C` and `$ROOTSYS/tutorials/multifit.C`.

Example: Fitting Multiple Sub Ranges

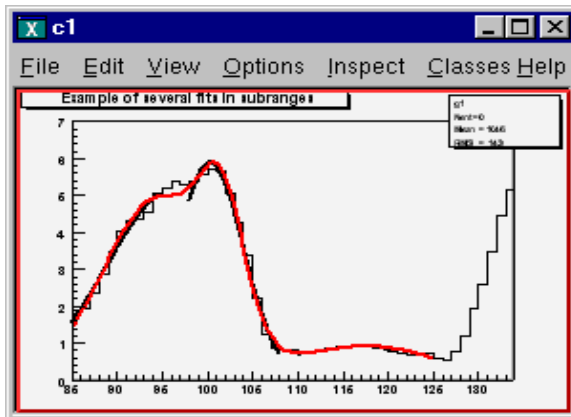

The script for this example is in macro `multifit.C` in `$ROOTSYS/tutorials/` directory. It shows how to use several Gaussian functions with different parameters on separate sub ranges of the same histogram.

To use a Gaussian, or any other ROOT built in function, on a sub range you need to define a new `TF1`. Each is 'derived' from the canned function `gaus`.

```
// Create 4 TF1 objects, one for each subrange
g1 = new TF1("m1","gaus",85,95);
g2 = new TF1("m2","gaus",98,108);
g3 = new TF1("m3","gaus",110,121);

// The total is the sum of the three, each has 3 parameters
total = new TF1("mstotal","gaus(0)+gaus(3)+gaus(6)",85,125);
```

Here we fill a histogram with bins defined in the array x (see \$ROOTSYS/tutorials/multifit.C).

```
// Create a histogram and set it's contents
h = new TH1F("g1","Example of several fits in subranges",np,85,134);
h->SetMaximum(7);
for (int i=0; i<np; i++) {
    h->SetBinContent(i+1,x[i]);
}

// Define the parameter array for the total function
Double_t par[9];
```

When fitting simple functions, such as a Gaussian, the initial values of the parameters are automatically computed by ROOT. In the more complicated case of the sum of 3 Gaussian functions, the initial values of parameters must be set. In this particular case, the initial values are taken from the result of the individual fits.

The use of the "+" sign is explained below:

```
// Fit each function and add it to the list of functions
h->Fit(g1,"R");
h->Fit(g2,"R+");
h->Fit(g3,"R+");

// Get the parameters from the fit
g1->GetParameters(&par[0]);
g2->GetParameters(&par[3]);
g3->GetParameters(&par[6]);

// Use the parameters on the sum
total->SetParameters(par);
h->Fit(total,"R+");
```

Adding Functions to the List

The example \$ROOTSYS/tutorials/multifit.C also illustrates how to fit several functions on the same histogram. By default a Fit command deletes the previously fitted function in the histogram object. You can specify the option "+" in the second parameter to add the newly fitted function to the existing list of functions for the histogram.

```
root[] hist->Fit("f1","+", "", -2,2)
```

Note that the fitted function(s) are saved with the histogram when it is written to a ROOT file.

Combining Functions

You can combine functions to fit a histogram with their sum. Here is an example, the code is in `$ROOTSYS/tutorials/FitDemo.C`. We have a function that is the combination of a background and lorentzian peak. Each function contributes 3 parameters.

$$y(E) = a_1 + a_2E + a_3E^2 + A_p (G/2p) / ((E-m)^2 + (G/2)^2)$$

background	lorentzianPeak
<code>par[0] = a₁</code>	<code>par[0] = A_p</code>
<code>par[1] = a₂</code>	<code>par[1] = G</code>
<code>par[2] = a₃</code>	<code>par[2] = m</code>

The combination function (`fitFunction`) has six parameters:

`fitFunction = background(x, par) + lorentzianPeak(x, &par[3])`

`par[0] = a1`
`par[1] = a2`
`par[2] = a3`
`par[3] = Ap`
`par[4] = G`
`par[5] = m`

This script creates a histogram and fits the combination of the two functions. First we define the two functions and the combination function:

```
// Quadratic background function
Double_t background(Double_t *x, Double_t *par) {
    return par[0] + par[1]*x[0] + par[2]*x[0]*x[0];
}
// Lorentzian Peak function
Double_t lorentzianPeak(Double_t *x, Double_t *par) {
    return (0.5*par[0]*par[1]/TMath::Pi()) / TMath::Max(1.e-10,
        (x[0]-par[2])*(x[0]-par[2]) + .25*par[1]*par[1]);
}
// Sum of background and peak function
Double_t fitFunction(Double_t *x, Double_t *par) {
    return background(x,par) + lorentzianPeak(x,&par[3]); }
void FittingDemo()
{
    // bevington exercise by P. Malzacher, modified by R. Brun
    const int nBins = 60;
    Stat_t data[nBins] = { 6, 1,10,12, 6,13,23,22,15,21,
        23,26,36,25,27,35,40,44,66,81,
        75,57,48,45,46,41,35,36,53,32,
        40,37,38,31,36,44,42,37,32,32,
        43,44,35,33,33,39,29,41,32,44,
        26,39,29,35,32,21,21,15,25,15};
    TH1F *histo = new TH1F("example_9_1",
        "Lorentzian Peak on Quadratic Background",60,0,3);

    for(int i=0; i < nBins; i++) {
        // we use these methods to explicitly set the content
        // and error instead of using the fill method.
        histo->SetBinContent(i+1,data[i]);
        histo->SetBinError(i+1,TMath::Sqrt(data[i]));
    }
}
// continued...
```

```

// create a TF1 with the range from 0 to 3 and 6 parameters
TF1 *fitFcn = new TF1("fitFcn",fitFunction,0,3,6);

// first try without starting values for the parameters
// this defaults to 1 for each param.
histo->Fit("fitFcn");
// this results in an ok fit for the polynomial function however
// the non-linear part (lorentzian) does not respond well
// second try: set start values for some parameters
fitFcn->SetParameter(4,0.2); // width
fitFcn->SetParameter(5,1); // peak

histo->Fit("fitFcn","V+");

// improve the picture:
TF1 *backFcn = new TF1("backFcn",background,0,3,3);
backFcn->SetLineColor(3);
TF1 *signalFcn = new TF1("signalFcn",lorentzianPeak,0,3,3);
signalFcn->SetLineColor(4);
Double_t par[6];

// writes the fit results into the par array
fitFcn->GetParameters(par);

backFcn->SetParameters(par);
backFcn->Draw("same");

signalFcn->SetParameters(&par[3]);
signalFcn->Draw("same");
}

```

This is the result:

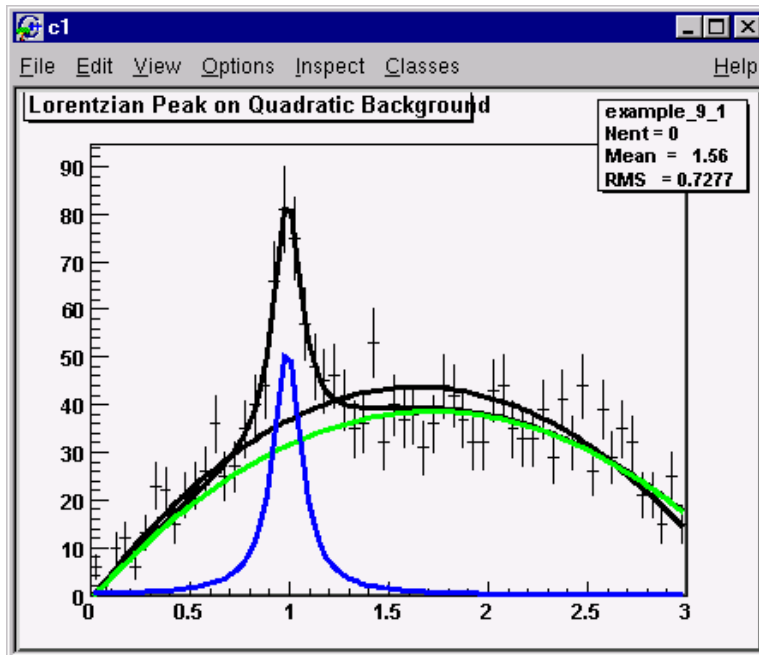

For another example see: <http://root.cern.ch/root/html/examples/backsig.C.html>

Associated Function

One or more objects (typically a **TF1***) can be added to the list of functions (`fFunctions`) associated to each histogram. A call to `TH1::Fit` adds the fitted function to this list. Given a histogram `h`, one can retrieve the associated function with:

```
TF1 *myfunc = h->GetFunction("myfunc");
```

Access to the Fit Parameters and Results

If the histogram (or graph) is made persistent, the list of associated functions is also persistent. Retrieve a pointer to the function with the `TH1::GetFunction()` method. Then you can retrieve the fit parameters from the function (**TF1**) with calls such as:

```
root[] TF1 *fit = hist->GetFunction(function_name);
root[] Double_t chi2 = fit->GetChisquare();
// value of the first parameter
root[] Double_t p1 = fit->GetParameter(0);
// error of the first parameter
root[] Double_t e1 = fit->GetParError(0);
```

Associated Errors

By default, for each bin, the sum of weights is computed at fill time. One can also call `TH1::Sumw2` to force the storage and computation of the sum of the square of weights per bin. If `Sumw2` has been called, the error per bin is computed as the `sqrt` (sum of squares of weights), otherwise the error is set equal to the `sqrt` (bin content). To return the error for a given bin number, do:

```
Double_t error = h->GetBinError(bin);
```

Fit Statistics

You can change the statistics box to display the fit parameters with the `TStyle::SetOptFit(mode)` method. This mode has four digits.

```
mode = pcev (default = 0111)
```

- `v = 1` print name/values of parameters
- `e = 1` print errors (if `e=1`, `v` must be 1)
- `c = 1` print Chi-square/number of degrees of freedom
- `p = 1` print probability

For example:

```
gStyle->SetOptFit(1011);
```

This prints the fit probability, parameter names/values, and errors.

The Minimization Package

This package was originally written in FORTRAN by Fred James and part of `PACKLIB` (patch D506). It has been converted to a C++ class by Rene Brun. The current implementation in C++ is a straightforward conversion of the original FORTRAN version. The main changes are:

- The variables in the various `Minuit` labeled common blocks have been changed to the `TMinuit` class data members
- The internal arrays with a maximum dimension depending on the maximum number of parameters are now data members' arrays with a dynamic dimension such that one can fit very large problems by simply initializing the `TMinuit` constructor with the maximum number of parameters
- The include file `Minuit.h` has been commented as much as possible using existing comments in the code or the printed documentation
- The original `Minuit` subroutines are now member functions
- Constructors and destructor have been added
- Instead of passing the `FCN` function in the argument list, the addresses of this function is stored as pointer in the data members of the class. This is by far more elegant and flexible in an interactive environment. The member function `SetFCN` can be used to define this pointer
- The ROOT static function `Printf` is provided to replace all format statements and to print on currently defined output file
- The derived class `TMinuitOld` contains obsolete routines from the FORTRAN based version
- The functions `SetObjectFit/GetObjectFit` can be used inside the `FCN` function to set/get a referenced object instead of using global variables
- By default `fGraphicsMode` is true. When calling the `Minuit` functions such as `mncont`, `mnsca`, or any `Minuit` command invoking `mnplot`, `TMinuit::mnplot()` produces a `TGraph` object pointed by `fPlot`. One can retrieve this object with `TMinuit::GetPlot()`. For example:

```
h->Fit("gaus");
gMinuit->Command("SCAN 1");

TGraph *gr = (TGraph*)gMinuit->GetPlot();
gr->SetMarkerStyle(21);
gr->Draw("alp");
```

- To set `Minuit` in no graphics mode, call

```
gMinuit->SetGraphicsMode(kFALSE);
```

Basic Concepts of Minuit

The `Minuit` package acts on a multi parameter FORTRAN function to which one must give the generic name `FCN`. In the ROOT implementation, the function `FCN` is defined via the `Minuit` `SetFCN` member function when a `HistogramFit` command is invoked. The value of `FCN` will in general depend on one or more variable parameters.

To take a simple example, in case of ROOT histograms (classes `TH1C`, `TH1S`, `TH1F`, `TH1D`) the `Fit` function defines the `Minuit` fitting function as being `H1FitChisquare` or `H1FitLikelihood` depending on the options selected. `H1FitChisquare` calculates the chi-square between the user fitting function (Gaussian, polynomial, user defined, etc) and the data for given values of the parameters. It is the task of `Minuit` to find those values of the parameters which give the lowest value of chi-square.

The Transformation of Limited Parameters

For variable parameters with limits, `Minuit` uses the following transformation:

$$P_{\text{int}} = \arcsin(2((P_{\text{ext}} - a) / (b - a)) - 1)$$

$$P_{\text{ext}} = a + ((b - a) / (2)) (\sin P_{\text{int}} + 1)$$

so that the internal value P_{int} can take on any value, while the external value P_{ext} can take on values only between the lower limit a and the upper limit b . Since the transformation is necessarily non-linear, it would transform a nice linear problem into a nasty non-linear one, which is the reason why limits should be avoided if not necessary. In addition, the transformation does require some computer time, so it slows down the computation a little bit, and more importantly, it introduces additional numerical inaccuracy into the problem in addition to what is introduced in the numerical calculation of the `FCN` value. The effects of non-linearity and numerical round off both become more important as the external value gets closer to one of the limits (expressed as the distance to nearest limit divided by distance between limits). The user must therefore be aware of the fact that, for example, if he puts limits of $(0, 10^{-10})$ on a parameter, then the values 0.0 and 1.0 will be indistinguishable to the accuracy of most machines.

The transformation also affects the parameter error matrix, of course, so `Minuit` does a transformation of the error matrix (and the "parabolic" parameter errors) when there are parameter limits. Users should however realize that the transformation is only a linear approximation, and that it cannot give a meaningful result if one or more parameters is very close to a limit, where $\partial P_{\text{ext}} / \partial P_{\text{int}} \neq 0$. Therefore, it is recommended that:

- Limits on variable parameters should be used only when needed in order to prevent the parameter from taking on unphysical values
- When a satisfactory minimum has been found using limits, the limits should then be removed if possible, in order to perform or re-perform the error analysis without limits

How to Get the Right Answer from Minuit

`Minuit` offers the user a choice of several minimization algorithms. The `MIGRAD` algorithm is in general the best minimized for nearly all functions. It is a variable-metric method with inexact line search, a stable metric updating scheme, and checks for positive-definiteness. Its main weakness is that it depends heavily on knowledge of the first derivatives, and fails miserably if they are very inaccurate.

If parameter limits are needed, in spite of the side effects, then the user should be aware of the following techniques to alleviate problems caused by limits:

Getting the Right Minimum with limits

If `MIGRAD` converges normally to a point where no parameter is near one of its limits, then the existence of limits has probably not prevented `Minuit` from finding the right minimum. On the other hand, if one or more parameters is near its limit at the minimum, this may be because the true minimum is indeed at a limit, or it may be because the minimized has become "blocked" at a limit. This may normally happen only if the parameter is so close to a limit (internal value at an odd multiple of $\pi / 2$) that `Minuit` prints a warning to this effect when it prints the parameter values. The minimized can become blocked at a limit, because at a limit the derivative seen by the minimized $\partial F / \partial P_{\text{int}}$ is zero no matter what the real derivative $\partial F / \partial P_{\text{ext}}$ is.

$$(\partial F / \partial P_{\text{int}}) =$$

$$(\partial F / \partial P_{\text{ext}}) (\partial P_{\text{ext}} / \partial P_{\text{int}}) =$$

$$(\partial F / \partial P_{\text{ext}}) = 0$$

Getting the Right Parameter Errors with Limits

In the best case, where the minimum is far from any limits, `Minuit` will correctly transform the error matrix, and the parameter errors it reports should be accurate and very close to those you would have got without limits. In other cases (which should be more common,

since otherwise you wouldn't need limits), the very meaning of parameter errors becomes problematic. Mathematically, since the limit is an absolute constraint on the parameter, a parameter at its limit has no error, at least in one direction. The error matrix, which can assign only symmetric errors, then becomes essentially meaningless.

Interpretation of Parameter Errors

There are two kinds of problems that can arise: the reliability of `Minuit`'s error estimates, and their statistical interpretation, assuming they are accurate.

Statistical Interpretation

For discussion of basic concepts, such as the meaning of the elements of the error matrix, or setting of exact confidence levels see the articles:

- F. James. *Determining the statistical Significance of experimental Results. Technical Report DD/81/02 and CERN Report 81-03, CERN, 1981*
- W.T.Eadie, D.Drijard, F.James, M.Roos, and B.Sadoulet. *Statistical Methods in Experimental Physics. North-Holland, 1971*

Reliability of Minuit Error Estimates

`Minuit` always carries around its own current estimates of the parameter errors, which it will print out on request, no matter how accurate they are at any given point in the execution. For example, at initialization, these estimates are just the starting step sizes as specified by the user. After a `HESSE` step, the errors are usually quite accurate, unless there has been a problem. `Minuit`, when it prints out error values, also gives some indication of how reliable it thinks they are. For example, those marked `CURRENT GUESS ERROR` are only working values not to be believed, and `APPROXIMATE ERROR` means that they have been calculated but there is reason to believe that they may not be accurate.

If no mitigating adjective is given, then at least `Minuit` believes the errors are accurate, although there is always a small chance that `Minuit` has been fooled. Some visible signs that `Minuit` may have been fooled are:

- Warning messages produced during the minimization or error analysis
- Failure to find new minimum
- Value of `EDM` too big (estimated Distance to Minimum)
- Correlation coefficients exactly equal to zero, unless some parameters are known to be uncorrelated with the others
- Correlation coefficients very close to one (greater than 0.99). This indicates both an exceptionally difficult problem, and one which has been badly parameterized so that individual errors are not very meaningful because they are so highly correlated
- Parameter at limit. This condition, signaled by a `Minuit` warning message, may make both the function minimum and parameter errors unreliable. See the discussion above 'Getting the right parameter errors with limits'

The best way to be absolutely sure of the errors, is to use "independent" calculations and compare them, or compare the calculated errors with a picture of the function. Theoretically, the covariance matrix for a "physical" function must be positive-definite at the minimum, although it may not be so for all points far away from the minimum, even for a well-determined physical problem. Therefore, if `MIGRAD` reports that it has found a non-positive-definite covariance matrix, this may be a sign of one or more of the following:

A non-physical region

On its way to the minimum, `MIGRAD` may have traversed a region which has unphysical behavior, which is of course not a serious problem as long as it recovers and leaves such a region.

An underdetermined problem

If the matrix is not positive-definite even at the minimum, this may mean that the solution is not well-defined, for example that there are more unknowns than there are data points, or

that the parameterization of the fit contains a linear dependence. If this is the case, then `Minuit` (or any other program) cannot solve your problem uniquely. The error matrix will necessarily be largely meaningless, so the user must remove the under determinedness by reformulating the parameterization. `Minuit` cannot do this itself.

Numerical inaccuracies

It is possible that the apparent lack of positive-definiteness is in fact only due to excessive round off errors in numerical calculations in the user function or not enough precision. This is unlikely in general, but becomes more likely if the number of free parameters is very large, or if the parameters are badly scaled (not all of the same order of magnitude), and correlations are also large. In any case, whether the non-positive-definiteness is real or only numerical is largely irrelevant, since in both cases the error matrix will be unreliable and the minimum suspicious.

An ill-posed problem

For questions of parameter dependence, see the discussion above on positive-definiteness. Possible other mathematical problems are the following:

Excessive numerical round off

Be especially careful of exponential and factorial functions which get big very quickly and lose accuracy.

Starting too far from the solution

The function may have unphysical local minima, especially at infinity in some variables.

6 A Little C++

This chapter introduces you to some useful insights into C++, to allow you to use of the most advanced features in ROOT. It is in no case a full course in C++.

Classes, Methods and Constructors

C++ extends C with the notion of class. If you're used to structures in C, a class is a `struct` that is a group of related variables, which is extended with functions and routines specific to this structure (class). What is the interest? Consider a `struct` that is defined this way:

```
struct Line {
    float x1;
    float y1;
    float x2;
    float y2;
}
```

This structure represents a line to be drawn in a graphical window. (x_1, y_1) are the coordinates of the first point, (x_2, y_2) the coordinates of the second point.

In standard C, if you want to effectively draw such a line, you first have to define a structure and initialize the points (you can try this):

```
Line firstline;
firstline.x1 = 0.2;
firstline.y1 = 0.2;
firstline.x2 = 0.8;
firstline.y2 = 0.9;
```

This defines a line going from the point $(0.2, 0.2)$ to the point $(0.8, 0.9)$. To draw this line, you will have to write a function, say `LineDraw(Line l)` and call it with your object as argument:

```
LineDraw(firstline);
```

In C++, we would not do that. We would instead define a class like this:

```
class TLine {
    Double_t x1;
    Double_t y1;
    Double_t x2;
    Double_t y2;
    TLine(int x1, int y1, int x2, int y2);
    void Draw();
}
```

Here we added two functions, that we will call methods or member functions, to the `TLine` class. The first method is used for initializing the line objects we would build. It is called a constructor. The second one is the `Draw` method itself.

Therefore, to build and draw a line, we have to do:

```
TLine l(0.2,0.2,0.8,0.9);  
l.Draw();
```

The first line builds the object `l` by calling its constructor. The second line calls the `TLine::Draw()` method of this object. You don't need to pass any parameters to this method since it applies to the object `l`, which knows the coordinates of the line. These are internal variables `x1`, `y1`, `x2`, `y2` that were initialized by the constructor.

Inheritance and Data Encapsulation

Inheritance

We've defined a `TLine` class that contains everything necessary to draw a line. If we want to draw an arrow, is it so different from drawing a line? We just have to draw a triangle at one end. It would be very inefficient to define the class `TArrow` from scratch. Fortunately, inheritance allows a class to be defined from an existing class. We would write something like:

```
class TArrow : public TLine {  
    int ArrowHeadSize;  
    void Draw();  
    void SetArrowSize(int arrowsize);  
}
```

The keyword "public" will be explained later. The class `TArrow` now contains everything that the class `TLine` does, and a couple of things more, the size of the arrowhead and a function that can change it. The `Draw` method of `TArrow` will draw the head and call the `Draw` method of `TLine`. We just have to write the code for drawing the head!

Method Overriding

Giving the same name to a method (remember: method = member function of a class) in the child class (`TArrow`) as in the parent (`TLine`) doesn't give any problem. This is called **overriding** a method. `Draw` in `TArrow` overrides `Draw` in `TLine`. There is no possible ambiguity since, when one calls the `Draw()` method; this applies to an object which type is known. Suppose we have an object `l` of type `TLine` and an object `a` of type `TArrow`. When you want to draw the line, you do:

```
l.Draw()
```

`Draw()` from `TLine` is called. If you do:

```
a.Draw()
```

`Draw()` from `TArrow` is called and the arrow `a` is drawn.

Data Encapsulation

We have seen previously the keyword "public". This keyword means that every name declared public is seen by the outside world. This is opposed to "private" that means only the class where the name was declared private could see this name. For example, suppose we declare in `TArrow` the variable `ArrowHeadSize` private.

```
private:  
    int ArrowHeadSize;
```

Then, only the methods (i.e. member functions) of `TArrow` will be able to access this variable. Nobody else will see it. Even the classes that we could derive from `TArrow` will not see it. On the other hand, if we declare the method `Draw()` as public, everybody will be

able to see it and use it. You see that the character `public` or `private` doesn't depend of the type of argument. It can be a data member, a member function, or even a class.

For example, in the case of `TArrow`, the base class `TLine` is declared as `public`:

```
class TArrow : public TLine { ...
```

This means that all methods of `TArrow` will be able to access all methods of `TLine`, but this will be also true for anybody in the outside world. Of course, this is true provided that `TLine` accepts the outside world to see its methods/data members. If something is declared `private` in `TLine`, nobody will see it, not even `TArrow` members, even if `TLine` is declared as a public base class.

What if `TLine` is declared "private" instead of "public"? Well, it will behave as any other name declared private in `TArrow`: only the data members and methods of `TArrow` will be able to access `TLine`, its methods and data members, nobody else.

This may seem a little bit confusing and readers should read a good C++ book if they want more details. Especially since, besides `public` and `private`, a member can be protected.

Usually, one puts private the methods that the class uses internally, like some utilities classes, and that the programmer doesn't want to be seen in the outside world.

With "good" C++ practice (which we have tried to use in `ROOT`), all data members of a class are private. This is called data encapsulation and is one of the strongest advantages of Object Oriented Programming (OOP). Private data members of a class are not visible, except to the class itself. So, from the outside world, if one wants to access those data members, one should use so called "getters" and "setters" methods, which are special methods used only to get or set the data members. The advantage is that if the programmers want to modify the inner workings of their classes, they can do so without changing what the user sees. The user doesn't even have to know that something has changed (for the better, hopefully).

For example, in our `TArrow` class, we would have set the data member `ArrowHeadSize` private. The setter method is `SetArrowSize()`, we don't need a getter method:

```
class TArrow : public TLine {
private:
    int ArrowHeadSize;
public:
    void Draw();
    void SetArrowSize(int arrowsize);
}
```

To define an arrow object you call the constructor. This will also call the constructor of `TLine`, which is the parent class of `TArrow`, automatically. Then we can call any of the line or arrow public methods such as `SetArrowSize` and `Draw`.

```
root[] TArrow *myarrow = new TArrow(1,5,89,124);
root[] myarrow->SetArrowSize(10);
root[] myarrow->Draw();
```

Creating Objects on the Stack and Heap

To explain how objects are created on the stack and on the heap we will use the `Quad` class. You can find the definition in `$ROOTSYS/tutorials/Quad.h` and `Quad.cxx`.

The `Quad` class has four methods. The constructor and destructor, `Evaluate` that evaluates $ax^2 + bx + c$, and `Solve` which solves the quadratic equation $ax^2 + bx + c = 0$.

Quad.h:

```
class Quad {
public:
    Quad(Float_t a, Float_t b, Float_t c);
    ~Quad();
    Float_t Evaluate(Float_t x) const;
    void Solve() const;
private:
    Float_t fA;
    Float_t fB;
    Float_t fC;
};
```

Quad.cxx:

```
#include <iostream.h>
#include <math.h>
#include "Quad.h"

Quad::Quad(Float_t a, Float_t b, Float_t c) {
    fA = a;
    fB = b;
    fC = c;
}

Quad::~Quad() {
    cout << "deleting object with coeffs: "
         << fA << ", " << fB << ", " << fC << endl;
}

Float_t Quad::Evaluate(Float_t x) const {
    return fA*x*x + fB*x + fC;
}

void Quad::Solve() const {
    Float_t temp = fB*fB - 4.*fA*fC;
    if ( temp > 0. ) {
        temp = sqrt( temp );
        cout << "There are two roots: "
             << ( -fB - temp ) / ( 2.*fA)
             << " and "
             << ( -fB + temp ) / ( 2.*fA)
             << endl;
    } else {
        if ( temp == 0. ) {
            cout << "There are two equal roots: "
                 << -fB / ( 2.*fA) << endl;
        } else {
            cout << "There are no roots" << endl;
        }
    }
}
```

Let's first look how we create an object. When we create an object by

```
root[] Quad my_object(1., 2., -3.);
```

We are creating an object on the stack. A FORTRAN programmer may be familiar with the idea; it's not unlike a local variable in a function or subroutine. Although there are still a few old timers who don't know it, FORTRAN is under no obligation to save local variables once the function or subroutine returns unless the SAVE statement is used. If not then it is likely that FORTRAN will place them on the stack and they will "pop off" when the RETURN statement is reached.

To give an object more permanence it has to be placed on the heap.

```
root[] .L Quad.cxx
root[] Quad *my_objptr = new Quad(1.,2.,-3.);
```

The second line declares a pointer to `Quad` called `my_objptr`. From the syntax point of view, this is just like all the other declarations we have seen so far, i.e. this is a stack variable. The value of the pointer is set equal to `new Quad(1.,2.,-3.)`;

`new`, despite its looks, is an operator and creates an object or variable of the type that comes next, `Quad` in this case, on the heap. Just as with stack objects it has to be initialized by calling its constructor. The syntax requires that the argument list follow the type. This one statement has brought two items into existence, one on the heap and one on the stack. The heap object will live until the delete operator is applied to it.

There is no FORTRAN parallel to a heap object; variables either come or go as control passes in and out of a function or subroutine, or, like a COMMON block variables, live for the lifetime of the program. However, most people in HEP who use FORTRAN will have experience of a memory manager and the act of creating a bank is a good equivalent of a heap object. For those who know systems like ZEBRA, it will come as a relief to learn that objects don't move, C++ does not garbage collect, so there is never a danger that a pointer to an object becomes invalid for that reason. However, having created an object, it is the user's responsibility to ensure that it is deleted when no longer needed, or to pass that responsibility onto to some other object. Failing to do that will result in a memory leak, one of the most common and most hard-to-find C++ bugs.

To send a message to an object via a pointer to it, you need to use the `"->"` operator e.g.:

```
root[] my_objptr->Solve();
```

Although we chose to call our pointer `my_objptr`, to emphasize that it is a pointer, heap objects are so common in an object-oriented program that pointer names rarely reflect the fact - you have to be careful that you know if you are dealing with an object or its pointer! Fortunately, the compiler won't tolerate an attempt to do something like:

```
root[] my_objptr.Solve();
```

Although this is permitted by the CINT shortcuts, it is one that you are *strongly* advised not to follow!

As we have seen, heap objects have to be accessed via pointers, whereas stack objects can be accessed directly. They can also be accessed via pointers:

```
root[] Quad stack_quad(1.,2.,-3.);
root[] Quad *stack_ptr = &stack_quad;
root[] stack_ptr->Solve();
```

Here we have a `Quad` pointer that has been initialized with the address of a stack object. Be very careful if you take the address of stack objects. As we shall see soon, they get deleted automatically, which could leave you with an illegal pointer. Using it will corrupt and may well crash the program!

It is time to look at the destruction of objects. A destructor is a special C++ function that releases resources for (or destroy) an object of a class. It is opposite of a constructor that create the object of a class when is called. The compiler will provide a destructor that does nothing if none is provided. We will add one to our `Quad` class so that we can see when it gets called.

The destructor is named by the class but with the prefix `~` which is the C++ one's complement i.e. bit wise complement, and hence has destruction overtones! We declare it in the `.h` file and define it in the `.cxx` file. It does not do much except print out that it has been called (still a useful debug technique despite today's powerful debuggers!).

Now run root, load the Quad class and create a heap object:

```
root[] .L Quad.cxx
root[] Quad *my_objptr = new Quad(1.,2.,-3.);
```

To delete the object:

```
root[] delete my_objptr;
root[] my_objptr = 0;
```

You should see the print out from its destructor. Setting the pointer to zero afterwards isn't strictly necessary (and CINT does it automatically), but the object is no more accessible, and any attempt to use the pointer again will, as has already been stated, cause grief.

So much for heap objects, but how do stack objects get deleted? In C++ a stack object is deleted as soon as control leaves the innermost compound statement that encloses it. So it is singularly futile to do something like:

```
root[] { Quad my_object(1.,2.,-3.); }
```

CINT does not follow this rule; if you type in the above line you will not see the destructor message. As explained in the Script lesson, you can load in compound statements, which would be a bit pointless if everything disappeared as soon as it was loaded! Instead, to reset the stack you have to type:

```
root[] gROOT->Reset();
```

This sends the Reset message via the global pointer to the ROOT object, which, amongst its many roles, acts as a resource manager. Start ROOT again and type in the following:

```
root[] .L Quad.cxx
root[] Quad my_object(1.,2.,-3.);
root[] Quad *my_objptr = new Quad(4.,5.,-6.);
root[] gROOT->Reset();
```

You will see that this deletes the first object but not the second. We have also painted ourselves into a corner, as `my_objptr` was also on the stack. This command will fail.

```
root[] my_objptr->Solve();
```

CINT no longer knows what `my_objptr` is. This is a great example of a memory leak; the heap object exists but we have lost our way to access it. In general, this is not a problem. If any object will outlive the compound statement in which it was created then it will be pointed to by a more permanent pointer, which frequently is part of another heap object. See [Resetting the Interpreter Environment](#) in the chapter [CINT the C++ Interpreter](#).

7 CINT the C++ Interpreter

The subject of this chapter is CINT, ROOT command line interpreter and script processor. First, we explain what CINT is and why ROOT uses it. Then CINT as the command line interpreter, the CINT commands, and CINT extensions to C++ are discussed. CINT as the script interpreter is also explained and illustrated with several examples.

What is CINT?

CINT, which is pronounced [*'sint*], is a C++ interpreter. An interpreter takes a program, in this case a C++ program, and carries it out by examining each instruction and in turn executing the equivalent sequence of machine language. For example, an interpreter translates and executes each statement in the body of a loop "n" times. It does not generate a machine language program. This may not be a good example, because most interpreters have become 'smart' about loop processing.

A compiler on the other hand, takes a program and makes a machine language executable. Once compiled the execution is very fast, which makes a compiler best suited for the case of "built once, run many times". For example, the ROOT executable is compiled occasionally and executed many times. It takes anywhere from 1 to 45 minutes to compile ROOT for the first time (depending on the CPU). Once compiled it runs very fast. On the average, a compiled program runs ten times faster than an interpreted one.

Because it takes much time to compile, using a compiler is cumbersome for rapid prototyping when one changes and rebuilds as often as every few minutes. An interpreter is optimized for code that changes often and runs a few times, is the perfect tool for this.

Most of the time, an interpreter has a separate scripting language, such as Python, IDL, and PERL, designed especially for interpretation, rather than compilation. However, the advantage of having one language for both is that once the prototype is debugged and refined, it can be compiled without translating the code to a compiled language.

CINT being a C++ interpreter is the tool for rapid prototyping and scripting in C++. It is a stand-alone product developed by Masaharu Goto. Its executable comes with the standard distribution of ROOT (`$ROOTSYS/bin/cint`), and it can also be installed separately from: <http://root.cern.ch/CINT.html>

This page also has links to all the CINT documentation. The downloadable tar file contains documentation, the CINT executable, and many demo scripts, which are not included in the regular ROOT distribution.

Here is a list of CINT main features:

- Supports K&R-C, ANSI-C, and ANSI-C++
- CINT covers 80-90% of the K&R-C, ANSI-C and C++ language constructs. It supports multiple inheritance, virtual function, function overloading, operator overloading, default parameter, template, and much more. CINT is robust enough to interpret its own source code. CINT is not designed to be a 100% ANSI/ISO compliant C++ language processor. It is a portable scripting language environment, which is close enough to the standard C++.
- Interprets Large C/C++ source code

- CINT can handle huge C/C++ source code, and loads source files quickly. It can interpret its own, over 70,000 lines source code.
- Enables mixing Interpretation & Native Code
- Depending on the need for execution speed or the need for interaction, one can mix native code execution and interpretation. "makeCINT" encapsulates arbitrary C/C++ objects as precompiled libraries. A precompiled library can be configured as a dynamically linked library. Accessing interpreted code and precompiled code can be done seamlessly in both directions.
- Provides a Single-Language solution
- CINT/makeCINT is a single-language environment. It works with any ANSI-C/C++ compiler to provide the interpreter environment on top of it.
- Simplifies C++
- CINT is meant to bring C++ to the non-software professional. C++ is simpler to use in the interpreter environment. It helps the non-software professional (the domain expert) to talk the same language as the software counterpart.
- Provides RTTI and a Command Line
- CINT can process C++ statements from command line, dynamically define/erase class definition and functions, load/unload source files and libraries. Extended Run Time Type Identification is provided, allowing you to explore unthinkable way of using C++.
- Has a Built-in Debugger and Class Browser
- CINT has a built-in debugger to debug complex C++ code. A text based class browser is part of the debugger.
- Is Portable
- CINT works on number of operating systems: HP-UX, Linux, SunOS, Solaris, AIX, Alpha-OSF, IRIX, FreeBSD, NetBSD, NEC EWS4800, NewsOS, BeBox, WindowsNT, Windows9x, MS-DOS, MacOS, VMS, NextStep, Convex.

The ROOT Command Line Interface

Start up a ROOT session by typing ROOT at the system prompt.

```

> root
*****
*
*           W E L C O M E   t o   R O O T           *
*
*   Version   3.05/03           25 March 2003   *
*
*   You are welcome to visit our Web site   *
*           http://root.cern.ch           *
*
*****

FreeType Engine v2.1.3 used to render TrueType fonts.
Compiled for linux with thread support.

CINT/ROOT C/C++ Interpreter version 5.15.80, Mar 17 2003
Type ? for help. Commands must be C++ statements.
Enclose multiple statements between { }.

root[0]

```

Now we create a **TLine** object:

```
root[] TLine l
root[] l.Print()
TLine X1=0.000000 Y1=0.000000 X2=0.000000 Y2=0.000000
root[] l.SetX1(10)
root[] l.SetY1(11)
root[] l.Print()
TLine X1=10.000000 Y1=11.000000 X2=0.000000 Y2=0.000000
root[] .g
...
0x4038f080 class TLine l , size=40
0x0      protected: Double_t fX1      //X of 1st point
0x0      protected: Double_t fY1      //Y of 1st point
0x0      protected: Double_t fX2      //X of 2nd point
0x0      protected: Double_t fY2      //Y of 2nd point
0x0      private: static class TClass* fgIsA
```

Here we note:

- Terminating with ';' is not required (see the section ROOT/CINT Extensions to C++).
- Emacs style command line editing.
- Raw interpreter commands start with a dot (.).

```
root[] .class TLine
=====
class TLine      //A line segment
  size=0x28
List of base class-----
0x0      public: TObject      //Basic ROOT object
0xc      public: TAttLine     //Line attributes
List of member variable-----
Defined in TLine
0x0      protected: Double_t fX1 //X of 1st point
0x0      protected: Double_t fY1 //Y of 1st point
0x0      protected: Double_t fX2 //X of 2nd point
0x0      protected: Double_t fY2 //Y of 2nd point
0x0      private: static class TClass* fgIsA
List of member function-----
Defined in TLine
filename  line:size busy function type and name
(compiled) 0:0  0 public: class TLine TLine(void);
(compiled) 0:0  0 public: Double_t GetX1(void);
(compiled) 0:0  0 public: Double_t GetX2(void);
(compiled) 0:0  0 public: Double_t GetY1(void);
(compiled) 0:0  0 public: Double_t GetY2(void);
...
...
(compiled) 0:0 public: virtual void SetX1(Double_t x1);
(compiled) 0:0 public: virtual void SetX2(Double_t x2);
(compiled) 0:0 public: virtual void SetY1(Double_t y1);
(compiled) 0:0 public: virtual void SetY2(Double_t y2);
(compiled) 0:0  0 public: void ~TLine(void);
root[] l.Print(); > test.log
root[] l.Dump(); >> test.log
root[] ?
```

Here we see:

- Use `.class` as quick help and reference
- Unix like I/O redirection (`;` is required before `>`)
- Use `?` to get help on all "raw" interpreter commands

Now let's execute a multi-line command:

```
root[] {
end with '}'> TLine l;
end with '}'> for (int i = 0; i < 5; i++) {
end with '}'>     l.SetX1(i);
end with '}'>     l.SetY1(i+1);
end with '}'>     l.Print();
end with '}'> }
end with '}'> }
TLine X1=0.000000 Y1=1.000000 X2=0.000000 Y2=0.000000
TLine X1=1.000000 Y1=2.000000 X2=0.000000 Y2=0.000000
TLine X1=2.000000 Y1=3.000000 X2=0.000000 Y2=0.000000
TLine X1=3.000000 Y1=4.000000 X2=0.000000 Y2=0.000000
TLine X1=4.000000 Y1=5.000000 X2=0.000000 Y2=0.000000
root[] .q
```

Here we note:

- A multi-line command starts with a { and ends with a }.
- Every line has to be correctly terminated with a ; (like in "real" C++).
- All objects are created in *global* scope.
- There is no way to back up; you are better off writing a script.
- Use `.q` to exit root.

The ROOT Script Processor

ROOT script files contain pure C++ code. They can contain a simple sequence of statements like in the multi command line example given above, but also arbitrarily complex class and function definitions.

Un-named Scripts

Let's start with a script containing a simple list of statements (like the multi-command line example given in the previous section). This type of script must start with a { and end with a } and is called an un-named script. Assume the file is called `script1.C`

```
{
#include <iostream.h>

cout << " Hello" << endl;
float x = 3.;
float y = 5.;
int i = 101;
cout << " x = "<<x<<" y = "<<y<<" i = "<<i<< endl;
}
```

To execute the stream of statements in `script1.C` do:

```
root[] .x script1.C
```

This loads the contents of file `script1.C` and executes all statements in the interpreter's *global* scope. One can re-execute the statements by re-issuing `".x script1.C"` (since there is no function entry point). Scripts are searched for in the `Root.MacroPath` as defined in your `.rootrc` file. To check which script is being executed use:

```
root[] .which script1.C
/home/rdm/root/./script1.C
```

Named Scripts

Let's change the un-named script to a named script. Copy the file `script1.C` to `script2.C` and add a function statement. Like this:

```
#include <iostream.h>

int main()
{
    cout << " Hello" << endl;
    float x = 3.;
    float y = 5.;
    int    i= 101;
    cout <<" x = "<<x<<" y = "<<y<<" i = "<<i<<endl;
    return 0;
}
```

Notice that **no** surrounding `{ }` are required in this case. To execute function `main()` in `script2.C` do:

```
root[] .L script2.C           // load script in memory
root[] main()                // execute entry point main
Hello
x = 3 y = 5 i = 101
(int)0
root[] main()                // execute main() again
Hello
x = 3 y = 5 i = 101
(int)0
root[] .func                  // list all functions known by CINT
filename      line:size busy function type and name
...
script2.C      4:9    0 public: int main();
```

The last command shows that `main()` has been loaded from file `script2.C`, that the function `main()` starts on line 4 and is 9 lines long.

Notice that once a function has been loaded it becomes part of the system just like a compiled function.

Now we copy file `script2.C` to `script3.C` and change the function name from `main()` to `script3(int j = 10)`:

```
#include <iostream.h>

int script3(int j = 10)
{
    cout << " Hello" << endl;
    float x = 3.;
    float y = 5.;
    int    i = j;
    cout <<" x = "<<x<<" y = "<<y<<" i = "<<i<<endl;
    return 0;
}
```

To execute `script3()` in `script3.C` type:

```
root[] .x script3.C(8)
```

This loads the contents of file `script3.C` and executes entry point `script3(8)`.

Note that the above only works when the filename (minus extension) and function entry point are both the same.

Function `script3()` can still be executed multiple times:

```
root[] script3()
Hello
x = 3 y = 5 i = 10
(int)0
root[] script3(33)
Hello
x = 3 y = 5 i = 33
(int)0
```

In a named script, the objects created on the stack are deleted when the function exits. For example, this scenario is very common. You create a histogram in a named script on the stack. You draw the histogram, but when the function exits the canvas is empty and the histogram disappeared.

To avoid histogram from disappearing you can create it on the heap (by using `new`). This will leave the histogram object intact, but the pointer in the named script scope will be deleted.

Since histograms (and trees) are added to the list of objects in the current directory, you can always retrieve them to delete them if needed.

```
root[] TH1F *h = (TH1F*)gDirectory->Get("myHist");
```

or

```
root[] TH1F *h = (TH1F*)gDirectory->GetList()->FindObject("myHist");
```

In addition, histograms and trees are automatically deleted when the current directory is closed. This will automatically take care of the clean up. See chapter [Input/Output](#).

Executing a Script from a Script

You may want to execute a script conditionally inside another script. To do it you need to call the interpreter and you can do that with `TROOT::ProcessLine()`.

Here is an example from `$ROOTSYS/tutorials/cernstaff.C` that calls a script to build the root file if it does not exist:

```
void cernstaff()
{
    if (gSystem->AccessPathName("cernstaff.root")) {
        gROOT->ProcessLine(".x cernbuild.C");
    }
    ...
}
```

`ProcessLine` takes a parameter which is a pointer to an `int` or to a `TInterpreter::EErrorCode` to let you access the CINT error code after an attempt to interpret. This will contain the CINT error as defined in `enum TInterpreter::EErrorCode`.

Resetting the Interpreter Environment

Variables created on the command line and in un-named scripts are in the interpreter's global scope, which makes the variables created in un-named scripts available on the command line event after the script is done executing. This is the opposite of a named script where the stack variables are deleted when the function in which they are defined has finished execution.

When running an un-named script over again and this is frequently the case since un-named scripts are used to prototype, one should reset the global environment to clear the variables. This is done by calling `gROOT->Reset()`. It is good practice, and you will see this in the

examples, to begin an un-named script with `gROOT->Reset()`. It clears the global scope to the state just before executing the previous script (not including any logon scripts).

The `gROOT->Reset()` calls the destructor of the objects if the object was created on the stack. If the object was created on the heap (via `new`) it is not deleted, but the variable is no longer associated with it. Creating variables on the heap in un-named scripts and calling `gROOT->Reset()` without you calling the destructor explicitly will cause a memory leak.

This may be surprising, but it follows the scope rules. For example, creating an object on the heap in a function (in a named script) without explicitly deleting it will also cause a memory leak. Since when exiting the function only the stack variables are deleted.

The code below shows `gROOT->Reset()` calling the destructor for the stack variable, but not for the heap variable. In the end, neither variable is available, but the memory for the heap variable is not released.

Here is an example:

```
root[] gDebug = 1
(const int)1
root[] TFile stackVar("stack.root", "RECREATE")
TKey Writing 86 bytes at address 64 for ID= stack.root Title=
root[] TFile *heapVar = new TFile("heap.root", "RECREATE")
TKey Writing 84 bytes at address 64 for ID= heap.root Title=
```

We turn on `Debug` to see what the subsequent calls are doing. Then we create two variables, one on the stack and one on the heap

```
root[] gROOT->Reset()
TKey Writing 48 bytes at address 150 for ID= stack.root Title=
TKey Writing 54 bytes at address 198 for ID= stack.root Title=
TFile dtor called for stack.root
TDirectory dtor called for stack.root
```

When we call `gROOT->Reset()`, `CINT` tells us that the destructor is called for the stack variable, but it doesn't mention the heap variable.

```
root[] stackVar
Error: No symbol stackVar in current scope FILE:/var/tmp/faaa01jWe_cint LINE:1
*** Interpreter error recovered ***
root[] heapVar
Error: No symbol heapVar in current scope FILE:/var/tmp/gaaa01jWe_cint LINE:1
*** Interpreter error recovered ***
```

Neither variable is available in after the call to `reset`.

```
root[] gROOT->FindObject("stack.root")
(class TObject*)0x0
root[] gROOT->FindObject("heap.root")
(class TObject*)0x106bfb30
```

The object on the stack is deleted and shows a null pointer when we do a `FindObject`. However, the heap object is still around and taking up memory.

A Script Containing a Class Definition

Lets create a small class `TMyClass` and a derived class `TChild`. The virtual method `TMyClass::Print()` is overridden in `TChild`. Save this in file called `script4.C`.

```
#include <iostream.h>
class TMyClass {
private:
    float    fX;        //x position in centimeters
    float    fY;        //y position in centimeters
public:
    TMyClass() { fX = fY = -1; }
    virtual void Print() const;
    void      SetX(float x) { fX = x; }
    void      SetY(float y) { fY = y; }
};

void TMyClass::Print() const        // parent print method
{
    cout << "fX = " << fX << ", fY = " << fY << endl;
}

class TChild : public TMyClass {
public:
    void Print() const;
};

void TChild::Print() const        // child print metod
{
    cout << "This is TChild::Print()" << endl;
    TMyClass::Print();
}
```

To execute `script4.C` do:

```
root[] .L script4.C
root[] TMyClass *a = new TChild
root[] a->Print()
This is TChild::Print()
fX = -1, fY = -1
root[] a->SetX(10)
root[] a->SetY(12)
root[] a->Print()
This is TChild::Print()
fX = 10, fY = 12
root[] .class TMyClass
=====
class TMyClass
  size=0x8 FILE:script4.C LINE:3
List of base class-----
List of member variable-----
Defined in TMyClass
0x0      private: float fX
0x4      private: float fY
List of member function-----
Defined in TMyClass
filename      line:size busy function type and name
script4.C      16:5      0 public: class TMyClass TMyClass(void);
script4.C      22:4      0 public: void Print(void);
script4.C      12:1      0 public: void SetX(float x);
script4.C      13:1      0 public: void SetY(float y);
root[] .q
```

As you can see an interpreted class behaves just like a compiled class.

There are some limitations for a class created in a script:

1. They cannot inherit from `TObject`. Currently the interpreter cannot patch the virtual table of compiled objects to reference interpreted objects.
2. Because the I/O is encapsulated in `TObject` and a class defined in a script can not inherit from `TObject`, it can not be written to a ROOT file.

For ways to add a class with a shared library and with ACLiC, see the chapter: ["Adding a Class"](#)

Debugging Scripts

A powerful feature of CINT is the ability to debug interpreted functions by means of setting breakpoints and being able to single step through the code and print variable values on the way. Assume we have `script4.C` still loaded, we can then do:

```
root[] .b TChild::Print
Break point set to line 26 script4.C
root[] a.Print()

26  TChild::Print() const
27  {
28      cout << "This is TChild::Print()" << endl;
FILE:script4.C LINE:28 cint> .s

311 operator<<(ostream& ostr,G__CINT_ENDL& i) {return(endl(ostr));
FILE:iostream.h LINE:311 cint> .s
}
This is TChild::Print()

29      MyClass::Print();
FILE:script4.C LINE:29 cint> .s

16  MyClass::Print() const
17  {
18      cout << "fX = " << fX << ", fY = " << fY << endl;
FILE:script4.C LINE:18 cint> .p fX
(float)1.0000000000000e+01
FILE:script4.C LINE:18 cint> .s

311 operator<<(ostream& ostr,G__CINT_ENDL& i) {return(endl(ostr));
FILE:iostream.h LINE:311 cint> .s
}
fX = 10, fY = 12

19  }

30  }

2   }
root[] .q
```

Inspecting Objects

An object of a class inheriting from `TObject` can be inspected, with the `Inspect` method. The `TObject::Inspect` method creates a window listing the current values of the objects members. For example, this is a picture of `TFile`.

```
root[] TFile f("staff.root")
root[] f.Inspect()
```

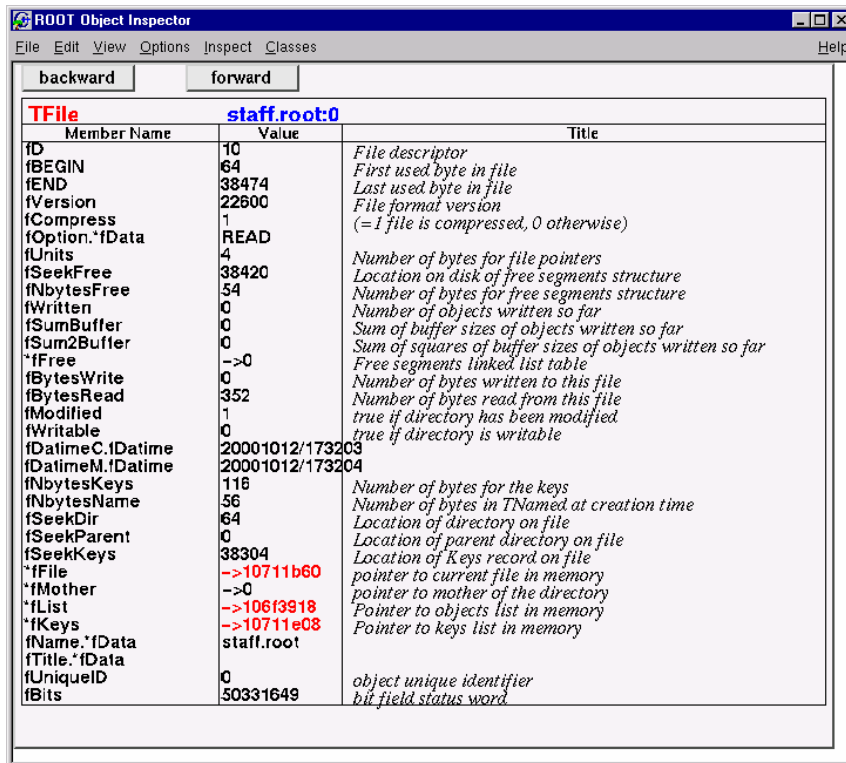

You can see the pointers are in red and can be clicked on to follow the pointer to the object. For example, here we clicked on `fKeys`, the list of keys in memory.

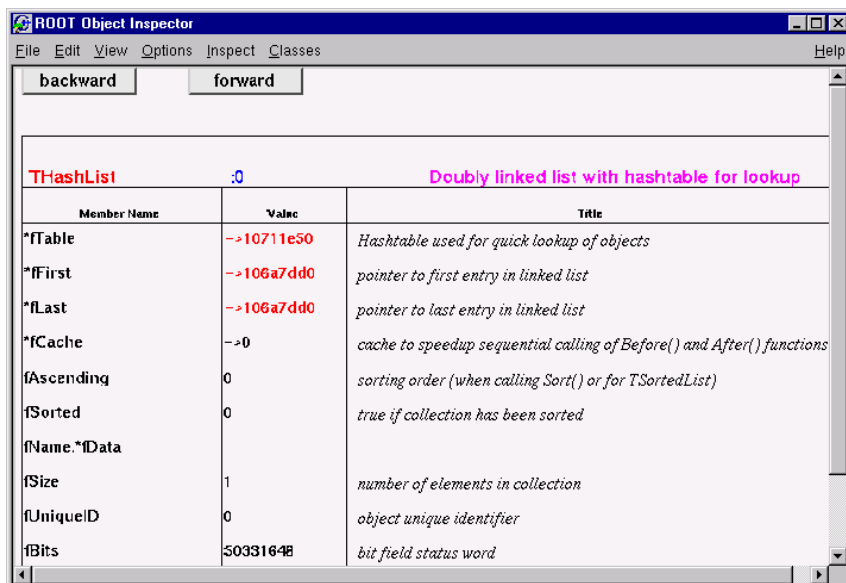

If you clicked on `fList`, the list of objects in memory and there were none, no new canvas would be shown. On top of the page are the navigation buttons to see the previous and next screen.

ROOT/CINT Extensions to C++

In the next example, we demonstrate three of the most important extensions ROOT/CINT makes to C++. Start ROOT in the directory \$ROOTSYS/tutorials (make sure to have first run ".x hsimple.C"):

```
root[] f = new TFile("hsimple.root")
(class TFile*)0x4045e690
root[] f.ls()
TFile**      hsimple.root
TFile*      hsimple.root
KEY: TH1F    hpx;1      This is the px distribution
KEY: TH2F    hpypy;1   py ps px
KEY: THProfile hprof;1 Profile of pz versus px
KEY: TNTuple ntuple;1   Demo ntuple
root[] hpx.Draw()
NULL
Warning in <MakeDefCanvas>: creating a default canvas with name c1
root[] .q
```

The *first* command shows the first extension; the declaration of `f` may be omitted when "new" is used. CINT will correctly create `f` as pointer to object of class `TFile`.

The *second* extension is shown in the second command. Although `f` is a pointer to `TFile` we don't have to use the pointer de-referencing syntax "->" but can use the simple "." notation.

The *third* extension is more important. In case CINT cannot find an object being referenced, it will ask ROOT to search for an object with an identical name in the search path defined by `TROOT::FindObject()`. If ROOT finds the object, it returns CINT a pointer to this object and a pointer to its class definition and CINT will execute the requested member function. This shortcut is quite natural for an interactive system and saves much typing. In this example, ROOT searches for `hpx` and finds it in `simple.root`.

The *fourth* is shown below. There is no need to put a semicolon at the end of a line. The difference between having it and leaving it off is that when you leave it off the return value of the command will be printed on the next line. For example:

```
root[] 23+5          // no semicolon prints the return value
(int)28
root[] 23+5;        // semicolon no return value is printed
root[]
```

Be aware that these extensions do not work when the interpreter is replaced by a compiler. Your code will not compile, hence when writing large scripts, it is best to stay away from these shortcuts. It will save you from having problems compiling your scripts using a real C++ compiler.

ACLIC - The Automatic Compiler of Libraries for CINT

Instead of having CINT interpret your script there is a way to have your scripts compiled, linked and dynamically loaded using the C++ compiler and linker. The advantage of this is that your scripts will run with the speed of compiled C++ and that you can use language constructs that are not fully supported by CINT. On the other hand, you cannot use any CINT shortcuts (see CINT extensions) and for small scripts, the overhead of the compile/link cycle might be larger than just executing the script in the interpreter.

ACLIC will build a CINT dictionary and a shared library from your C++ script, using the compiler and the compiler options that were used to compile the ROOT executable. You do not have to write a `makefile` remembering the correct compiler options, and you do not have to exit ROOT.

Usage

Before you can compile your interpreted script you need to add include statements for the classes used in the script. Once you did that, you can build and load a shared library containing your script. To load it, use the `.L` command and append the file name with a "+".

```
root[] .L MyScript.C+
root[] .files
...
*file="/home/./MyScript_C.so"
```

The + option generates the shared library and naming it by taking the name of the file "filename" but replacing the dot before the extension by an underscore and by adding the shared library extension for the current platform.

For example on most platforms, `hsimple.cxx` will generate `hsimple_cxx.so`.

If we execute a `.files` command we can see the newly created shared library is in the list of loaded files.

The + command rebuild the library only if the script or any of the files it includes are newer than the library. When checking the timestamp, ACLiC generates a dependency file which name is the same as the library name, just replacing the 'so' extension by the extension 'd'. For example on most platforms, `hsimple.cxx` will generate `hsimple_cxx.d`.

To ensure that the shared library is rebuilt you can use the ++ syntax:

```
root[] .L MyScript.C++
```

To build, load, and execute the function with the same name as the file you can use the `.x` command. This is the same as executing a named script. You can have parameters and use `.x` or `.X`. The only difference is you need to append a + or a ++.

```
root[] .x MyScript.C+ (4000)
Creating shared library /home/./MyScript_C.so
```

You can select whether the script is compiled with debug symbol or with optimization by appending the letter 'g' or 'O' after the '+' or '++'. Without the specification the script is compiled with the same level of debugging symbol and optimization as the currently running ROOT executable.

For example:

```
root[] .L MyScript.C++g
```

will compile `MyScript.C` with debug symbol; usually this means giving the `-g` option to compiler.

```
root[] .L MyScript.C++O
```

will compile `MyScript.C` with optimizations; usually this means giving the `-O` option to compiler. The syntax:

```
root[] .L MyScript.C++
```

is using the default optimization level. The initial default is to compile with the same level of optimization as the root executable itself. The default can be changed by:

```
root[] gSystem->SetAclicMode(TSystem::kDebug);
root[] gSystem->SetAclicMode(TSystem::kOpt);
```

Note that the commands:

```
root[] .L MyScript.C+g
root[] .L MyScript.C+O
```

respectively compile `MyScript.C` with debug and optimization if the library does not exist yet; they will not change the debug and the optimization level if the library already exist and it is up to date.

To use ACLiC from compiled code or from inside another macro, we recommend using `TROOT::ProcessLine()`.

For example, in one script you can use ACLiC to compile and load another script.

```
gROOT->ProcessLine("MyScript.C+")
gROOT->ProcessLine("MyScript.C++")
```

Setting the Include Path

You can get the include path by typing:

```
root[] .include
```

You can append to the include path by typing:

```
root[] .include $HOME/mypackage/include
```

In a script you can set the include path:

```
gSystem->SetIncludePath(" -I$HOME/mypackage/include ")
```

The `$ROOTSYS/include` directory is automatically appended to the include path, so you don't have to worry about including it, however if you have already added a path, this command will overwrite it.

To add library that should be used during linking of the shared library use something like:

```
TString libs = gSystem->GetLinkedLibs();
libs.Append("-L/my/path -lanyl");
gSystem->SetLinkedLibs(libs.Data());
```

This is especially useful for static libraries. For shared libraries you can also simply load them before trying to compile the script:

```
gSystem->Load("mydir/mylib");
```

You can direct what is added to the dictionary generated by ACLiC in two ways. The simplest way is to add at the end of script (i.e. after the symbols have been defined) something like:

```
#if defined(__MAKECINT__)
#pragma link C++ class MyOtherClass;
#endif
```

In ROOT 3.05/03 and above, the default behavior of `rootcint` is to not link in (i.e. generate the dictionary for) any of the symbols. In particular this means that the lines:

```
#pragma link off all globals;
#pragma link off all classes;
#pragma link off all functions;
```

are now, in the general case, unnecessary.

This also means that linking the instantiation of a class template:

```
#pragma link C++ class mytemplate<int>;
```

ONLY links this specific class. In previous versions of ROOT, depending on many factors, this might also have included the linking of many other instantiation of class template used directly or indirectly by 'mytemplate'.

A typical case would have been to rely on:

```
#pragma link C++ class vector<MyClass>;
```

to also induce the generation of the iterators. You now need to explicitly request them. Another advantage of the change is that now, if you omit the 'pragma link off' line from your linkdef file, you can actually sprinkle the 'pragma link C++ class' across as many of your header as file as you need.

See the documentation of `rootcint` for details how `pragma` can be used.

You can also write this portion of code in a file name `MyScript_linkdef.h` where the suffix `'_linkdef'` is the prefix defined by the key `'ACLIC.Linkdef'` in the currently used resource file (usually `$ROOTSYS/etc/system.rootrc` or `.rootrc`) and the prefix is the name of your script.

ACLIC uses the directive `fMakeSharedLibs` to create the shared library. If loading the shared library fails, it tries to output a list of missing symbols by creating an executable (on some platforms like OSF, this does not HAVE to be an executable) containing the script. It uses the directive `fMakeExe` to do so. For both directives, before passing them to `TSystem::Exec()`, it expands the variables `$SourceFiles`, `$SharedLib`, `$LibName`, `$IncludePath`, `$LinkedLibs`, `$ExeName` and `$ObjectFiles`. See `SetMakeSharedLib()` for more information on those variables.

NOTE: You should not call ACLIC with a script that has a function called `main()`. When ACLIC calls `rootcint` with a function called `main` it tries to add every symbol it finds while parsing the script and the header files to the dictionary. This includes the system header files and the ROOT header files. This will result in duplicate entries at best and crashes at worst, because some classes in ROOT need special attention before they can be added to the dictionary.

When the file being passed to ACLIC is on a read only file system, ACLIC warns the user and creates the library in a temporary directory:

```
root [0] .L readonly/t.C++
Warning in <ACLIC>: /scratch/aclic/subs/./readonly is not writeable!
Warning in <ACLIC>: Output will be written to /tmp
Info in <TUnixSystem::ACLIC>: creating shared library
/tmp//scratch/aclic/subs/./readonly/t_C.so
```

To select the temporary directory ACLIC looks at `$TEMP`, `$TEMP_DIR`, `$TEMPDIR`, `$TMP`, `$TMPDIR`, `$TMP_DIR` or uses `/tmp` (or `C:/`).

Also, a new interface `TSystem::Get/SetBuildDir` is introduced to let the user select an alternative 'root' for the building of the ACLIC libraries.

For the filename `/full/path/name/macro.C`, the library is created as `'fBuildDir'/full/path/name/macro_C.so`.

Also, the ACLIC linkdef does NOT contain anymore `pragma link off`. This means, that you can now steer the dictionary generation from within the script itself. However beware of multiple inclusions!

ACLIC will now obey ALL `pragma link C++` it sees!

Intermediate Steps and Files

ACLiC executes two steps and a third one if needed. These are:

- Calling `rootcint` to create a CINT dictionary. `rootcint` is a ROOT specific version of `makecint`, CINT generic dictionary generator.
- Calling the compiler to build the shared library from the script
- If there are errors, it calls the compiler to build a dummy executable to clearly report unresolved symbols.

ACLiC makes a shared library with a CINT dictionary containing the classes and functions declared in the script. It also adds the classes and functions declared in included files with the same name as the script file and any of the following extensions: `.h`, `.hh`, `.hpp`, `.hxx`, `.hPP`, `.hXX`. This means that, by default, you cannot combine scripts from different files into one library by using `#include` statements; you will need to compile each script separately. In a future release, we plan to add the global variables declared in the script to the dictionary also. If you are curious about the specific calls, you can raise the ROOT debug level:

```
gDebug = 3
```

ACLiC will print the three steps.

Moving between Interpreter and Compiler

The best way to develop portable scripts is to make sure you can always run them with both, the interpreter and with ACLiC. To do so, do not use the CINT extensions and program around the CINT limitations. When it is not possible or desirable to program around the CINT limitations, you can use the C preprocessor symbols defined for CINT and `rootcint`.

The preprocessor symbol `__CINT__` is defined for both CINT and `rootcint`. The symbol `__MAKECINT__` is only defined in `rootcint`.

Use `!defined(__CINT__) || defined(__MAKECINT__)` to bracket code that needs to be seen by the compiler and `rootcint`, but will be invisible to the interpreter.

Use `!defined(__CINT__)` to bracket code that should be seen only by the compiler and not by CINT or `rootcint`.

For example, the following will hide the declaration and initialization of the array `gArray` from both CINT and `rootcint`.

```
#if !defined(__CINT__)
int gArray[] = { 2, 3, 4};
#endif
```

Because ACLiC calls `rootcint` to build a dictionary, the declaration of `gArray` will not be included in the dictionary, and consequently, `gArray` will not be available at the command line even if ACLiC is used. CINT and `rootcint` will ignore all statements between the `"#if !defined (__CINT__)"` and `"#endif"`.

If you want to use `gArray` in the same script as its declaration, you can do so. However, if you want use the script in the interpreter you have to bracket the usage of `gArray` between `#if`'s, since the definition is not visible.

If you add the following preprocessor statements:

```
#if !defined(__CINT__)
int gArray[] = { 2, 3, 4};
#elif defined(__MAKECINT__)
int gArray[];
#endif
```

`gArray` will be visible to `rootcint` but still not visible to CINT. If you use ACLiC, `gArray` will be available at the command line and be initialized properly by the compiled code.

We recommend you always write scripts with the needed include statements. In most cases, the script will still run with the interpreter. However, a few header files are not handled very well by CINT.

These types of headers can be included in interpreted and compiled mode:

- The subset of standard C/C++ headers defined in `$ROOTSYS/cint/include`.
- Headers of classes defined in a previously loaded library (including ROOT own). The defined class must have a name known to ROOT (i.e. a class with a `ClassDef`).

A few headers will cause problems when they are included in interpreter mode, because they are already included by the interpreter itself. In general, the interpreter needs to know whether to use the interpreted or compiled version. The mode of the definition needs to match the mode of the reference.

Here are the cases that need to be excluded in interpreted mode, but included for `rootcint`. Bracket these with:

```
!defined(__CINT__) || defined(__MAKECINT__)
```

- All CINT headers, see `$ROOTSYS/cint/inc`
- Headers with classes named other than the file name. For example: `Rtypes.h` and `GuiTypes.h`.
- Headers with a class defined in libraries before the library is loaded. For example: having `#include "TLorentzVector.h` before `gSystem->Load("libPhysics")`. This will also cause problems when compiling the script, but a clear error message will be given. With the interpreter it may core dump. Bracket these type of include statements with `#if !defined (__CINT__)`, this will print an error in both modes.

Hiding header files from `rootcint` that are necessary for the compiler but optional for the interpreter can lead to a subtle but fatal error. For example:

```
#ifndef __CINT__
#include "TTree.h"
#else
class TTree;
#endif

class subTree : public TTree {
};
```

In this case, `rootcint` does not have enough information about the `TTree` class to produce the correct dictionary file. If you try this, `rootcint` and compiling will be error free, however, instantiating a `subTree` object from the CINT command line will cause a fatal error.

In general it is recommended to let `rootcint` see as many header files as possible.

8 Object Ownership

An object has ownership of another object if it has permission to delete it. Usually ownership is held by a collection or a parent object such as a pad.

To prevent memory leaks and multiple attempts to delete an object, you need to know which objects are owned by ROOT and which are owned by you.

The following rules apply to the ROOT classes.

- Histograms, trees, and event lists created by the user are owned by current directory (*gDirectory*). When the current directory is closed or deleted the objects it owns are deleted also.
- The **TROOT** master object (*gROOT*) has several collections of objects. Objects that are members of these collections are owned by *gROOT* (see the paragraph "Ownership by the Master **TROOT** Object (*gROOT*)" below).
- Objects created by another object, for example the function object (e.g. **TF1**) created by the **TH1::Fit** method is owned by the histogram.
- An object created by *DrawCopy* methods, is owned by the pad it is drawn in.

If an object fits none of these cases, the user has ownership. The next paragraphs describe each rule and user ownership in more detail.

Ownership by Current Directory (*gDirectory*)

When a histogram, tree, or event list (**TEventList**) is created, it is added to the list of objects in the current directory by default. You can get the list of objects in a directory and retrieve a pointer to a specific object with the *GetList* method. This example retrieves a histogram.

```
TH1F *h = (TH1F*)gDirectory->GetList()->FindObject("myHist");
```

The method **TDirectory::GetList()** returns a **TList** of objects in the directory. It looks in memory, and is implemented in all ROOT collections.

You can change the directory of a histogram, tree, or event list with the *SetDirectory* method. Here we use a histogram for an example, but the same applies to trees and event lists.

```
h->SetDirectory(newDir)
```

You can also remove a histogram from a directory by using *SetDirectory(0)*. Once a histogram is removed from the directory, it will not be deleted when the directory is closed. It is now your responsibility to delete this histogram once you have finished with it.

To change the default that automatically adds the histogram to the current directory, you can call the static function:

```
TH1::AddDirectory(kFALSE);
```

All histograms created here after will not be added to the current directory. In this case, you own all histogram objects and you will need to delete them and clean up the references.

You can still set the directory of a histogram by calling `SetDirectory` once it has been created as described above.

Note that, when a file goes out of scope or is closed all objects on its object list are deleted.

Ownership by the Master TROOT Object (*gROOT*)

The master object *gROOT*, maintains several collections of objects. For example, a canvas is added to the collection of canvases and it is owned by the canvas collection.

TSeqCollection* fFiles	List of files (TFile)
TSeqCollection* fMappedFiles	List of memory mapped files (TMappedFile)
TSeqCollection* fSockets	List of network sockets (TSocket and TServerSocket)
TSeqCollection* fCanvases	List of canvases (TCanvas)
TSeqCollection* fStyles	List of styles (TStyle)
TSeqCollection* fFunctions	List of analytic functions (TF1, TF2, TF3)
TSeqCollection* fTasks	List of tasks (TTask)
TSeqCollection* fColors	List of colors (TColor)
TSeqCollection* fGeometries	List of geometries (?)
TSeqCollection* fBrowsers	List of browsers (TBrowser)
TSeqCollection* fSpecials	List of special objects
TSeqCollection* fCleanups	List of recursiveRemove collections

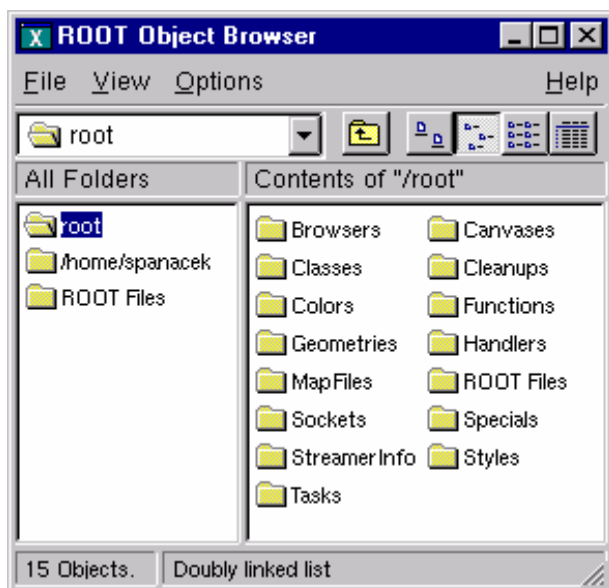

These collections are also displayed in the root folder of the Object Browser. Most of these collections are self explanatory. The special cases are the collections of specials and cleanups.

The Collection of Specials

This collection contains objects of the following classes: **TCut**, **TMultiDimFit**, **TPrincipal**, **TChains**. In addition it contains the `gHtml` object, `gMinuit` objects, and the array of contours graphs (**TGraph**) created when calling the `Draw` method of a histogram with the "CONT, LIST" option.

Access to the Collection Contents

The current content for the collection listed above can be accessed with the corresponding `gROOT->GetListOf` method (for example `gROOT->GetListOfCanvases`). In addition, `gROOT->GetListOfBrowsables` returns a collection of all objects visible on the left side panel in the browser (see the image of the Object Browser above).

Ownership by Other Objects

When an object is created by another, the creating object is the owner of the one it created. For example:

```
myHisto->Fit("gaus")
```

The call to `Fit` copies the global `TF1` Gaussian function and attaches the copy to the histogram. When the histogram is deleted, the copy is deleted also.

When a pad is deleted or cleared, all objects in the pad with the `kCanDelete` bit set are automatically deleted. Currently the objects created by the `DrawCopy` methods, have the `kCanDelete` bit set and are therefore owned by the pad.

Ownership by the User

The user owns all objects not described in one of the above cases. `TObject` has two bits, `kCanDelete` and `kMustCleanup`, that influence how an object is managed (in `TObject::fBits`). These are in an enumeration in `TObject.h`. To set these bits do:

```
MyObject->SetBit(kCanDelete)
MyObject->SetBit(kMustCleanup)
```

The bits can be reset and tested with the `TObject::ResetBit` and `TObject::TestBit` methods.

The `kCanDelete` Bit

The `gROOT` collections (see above) own their members and will delete them regardless of the `kCanDelete` bit. In all other collections, when the collection `Clear` method is called (i.e. `TList::Clear()`), members with the `kCanDelete` bit set, are deleted and removed from the collection. If the `kCanDelete` bit is not set, the object is only removed from the collection but not deleted.

If a collection `Delete` (`TList::Delete()`) method is called, all objects in the collection are deleted without considering the `kCanDelete` bit.

It is important to realize that deleting the collection (i.e. `delete MyCollection`), DOES NOT delete the members of the collection. If the user specified `MyCollection->SetOwner()` the collection owns the objects and `delete MyCollection` will delete all its members.

Otherwise you need to:

```
// delete all member objects in the collection
MyCollection->Delete();

// and delete the collection object
delete MyCollection;
```

Note that `kCanDelete` is automatically set by the `DrawCopy` method and it can be set for any object by the user.

For example, all graphics primitives must be managed by the user. If you want `TCanvas` to delete the primitive you created you have to set the `kCanDelete` bit.

The `kCanDelete` bit setting is displayed with `TObject::ls()`. The last number is either 1 or 0 and is the `kCanDelete` bit.

```

root[] TCanvas MyCanvas ("MyCanvas")
root[] MyCanvas.Divide (2,1)
root[] MyCanvas->cd(MyCanvas_1)
root[] hstat.Draw() // hstat is an existing TH1F
root[] MyCanvas->cd(MyCanvas_2)
root[] hstat.DrawCopy() // DrawCopy sets the kCanDelete bit
(class TH1*)0x88e73f8
root[] MyCanvas.ls()
Canvas Name=MyCanvas ...
  TCanvas ... Name= MyCanvas ...
    TPad ... Name= MyCanvas_1 ...
      TFrame ...
      OBJ: TH1F hstat Event Histogram : 0
      TPaveText ... title
      TPaveStats ... stats
    TPad ... Name= MyCanvas_2 ...
      TFrame ...
      OBJ: TH1F hstat Event Histogram : 1
      TPaveText ... title
      TPaveStats ... stats

```

The kMustCleanup Bit

When the `kMustCleanup` bit is set, the object destructor will remove the object and its references from all collections in the clean up collection (`gROOT::fCleanups`).

An object can be in several collections, for example if an object is in a browser and on two canvases. If the `kMustCleanup` bit is set, it will automatically be removed from the browser and both canvases when the destructor of the object is called.

`kMustCleanup` is set

- When an object is added to a pad (or canvas) in `TObject::AppendPad`.
- When an object is added to a `TBrowser` with `TBrowser::Add`.
- When an object is added to a `TFolder` with `TFolder::Add`.
- When creating an inspector canvas with `TInspectCanvas::Inspector`
- When creating a `TCanvas`.
- When painting a frame for a pad, the frame's `kMustCleanup` is set in `TPad::PaintPadFrame`

The user can add his own collection to the collection of clean ups, to take advantage of the automatic garbage collection.

For example:

```

// create two list
TList *myList1, *myList2;

// add both to of clean ups
gROOT->GetListOfCleanUps()->Add(myList1);
gROOT->GetListOfCleanUps()->Add(myList2);

// assuming myObject is in myList1 and myList2, when calling:
delete myObject;

// the object is deleted from both lists

```

9 Graphics and the Graphical User Interface

Graphical capabilities of ROOT range from 2D objects (lines, polygons, arrows) to various plots, histograms, and 3D graphical objects. In this chapter, we are going to focus on principals of graphics and 2D objects. Plots and histograms are discussed in a chapter of their own.

Drawing Objects

In ROOT, most objects derive from a base class `TObject`. This class has a virtual method `Draw()` so all objects are supposed to be able to be "drawn". The basic whiteboard on which an object is drawn is called a canvas (defined by the class `TCanvas`). If several canvases are defined, there is only one active at a time. One draws an object in the active canvas by using the statement:

```
object.Draw()
```

This instructs the object "object" to draw itself. If no canvas is opened, a default one (named "c1") is instantiated and is drawn.

```
root[] TLine a(0.1,0.1,0.6,0.6)
root[] a.Draw()
<TCanvas::MakeDefCanvas>: created default TCanvas with name c1
```

The first statement defines a line and the second one draws it. A default canvas is drawn since there was no opened one.

Interacting with Graphical Objects

When an object is drawn, one can interact with it. For example, the line drawn in the previous paragraph may be moved or transformed. One very important characteristic of ROOT is that transforming an object on the screen will also transform it in memory. One actually interacts with the real object, not with a copy of it on the screen. You can try for instance to look at the starting X coordinate of the line:

```
root[] a.GetX1()
(double)1.000000000e-1
```

`X1` is the `x` value of the starting coordinate given in the definition above.

Now move it interactively by clicking with the left mouse button in the line's middle and try to do again:

```
root[] a.GetX1 ()
(Double_t)1.31175468483816005e-01
```

You do not obtain the same result as before, the coordinates of 'a' have changed. As said, interacting with an object on the screen changes the object in memory.

Moving, Resizing and Modifying Objects

Changing the graphic objects attributes can be done with the GUI or programmatically. First, let's see how it is done in the GUI.

The Left Mouse Button

As was just seen moving or resizing an object is done with the left mouse button. The cursor changes its shape to indicate what may be done:

Point the object or one part of it:



Rotate:



Resize (exists also for the other directions):



Enlarge (used for text):



Move:



Here are some examples of

Moving:

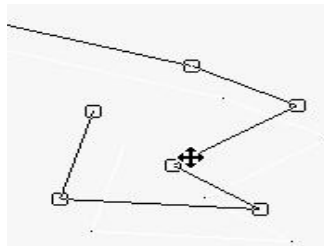

Resizing:

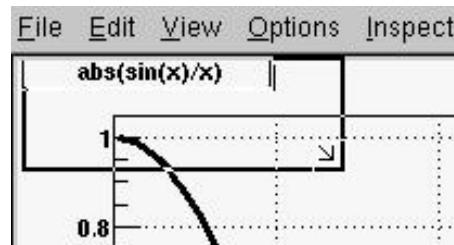

Rotating:

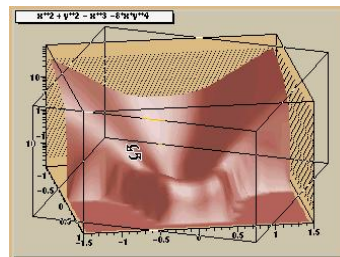

With C++ Statements (Programmatically)

How would one move an object in a script? Since there is a tight correspondence between what is seen on the screen and the object in memory, changing the object changes it on the screen. For example, try to do:

```
root[] a.SetX1 (0.9)
```

This should change one of the coordinates of our line, but nothing happens on the screen. Why is that? In short, the canvas is not updated with each change for performance reasons. See the sub section on: "Updating the Pad" in the next section.

Selecting Objects

The Middle Mouse Button

Objects in a canvas, as well as in a pad, are stacked on top of each other in the order they were drawn. Some objects may become "active" objects, which mean they are reordered to be on top of the others. To interactively make an object "active", you can use the middle mouse button. In case of canvases or pads, the border becomes highlighted when it is active.

With C++ Statements (Programmatically)

Frequently we want to draw in different canvases or pads. By default, the objects are drawn in the active canvas. To activate a canvas you can use the "TPad : :cd () " method.

```
root[] c1->cd()
```

Context Menus: the Right Mouse Button

The context menus are a way to interactively call certain methods of an object. When designing a class, the programmer can add methods to the context menu of the object by making minor changes to the header file.

Using Context Menus

On a ROOT canvas, you can right-click on any object and see the context menu for it. The script `hsimple.C` draws a histogram. The image below shows the context menus for some of the objects on the canvas. Next picture shows that drawing a simple histogram involves as many as seven objects. When selecting a method from the context menu and that method has options, the user will be asked for numerical values or strings to fill in the option. For example, `TAxis::SetTitle` will prompt you for a string to use for the axis title.

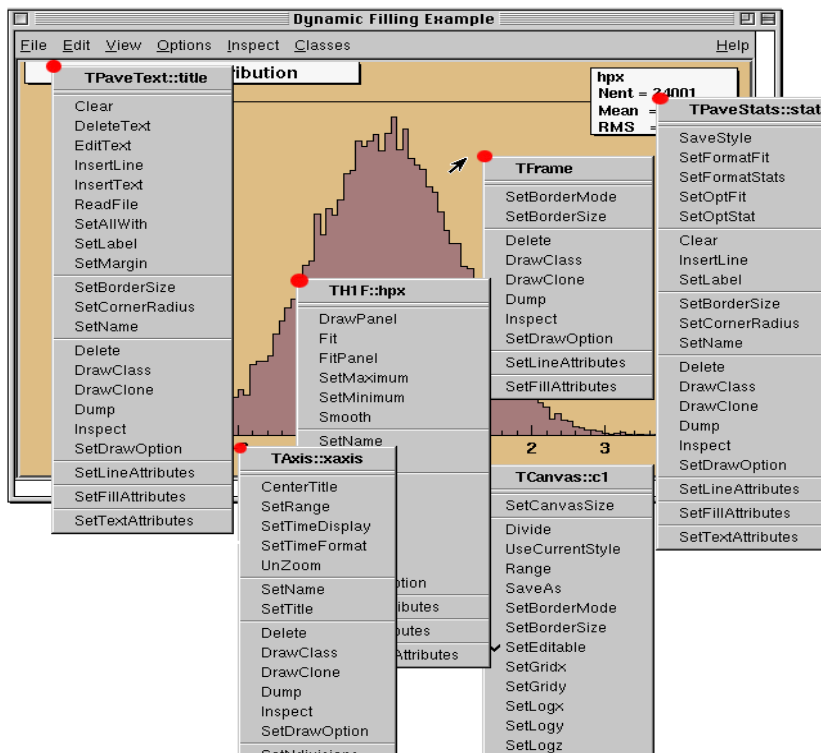

Structure of the Context Menus

The curious reader will have noticed that each entry in the context menu corresponds to a method of the class.

Look for example to the menu named `TAxis::xaxis`. `xaxis` is the name of the object and `TAxis` the name of its class. If we look at the list of `TAxis` methods, for example in <http://www.root.ch/root/html/TAxis.html>, we see the methods `SetTimeDisplay()` and `UnZoom()`, which appear also in the context menu.

There are several divisions in the context menu, separated by lines. The top division is a list of the class methods; the second division is a list of the parent class methods. The subsequent divisions are the methods other parent classes in case of multiple inheritance.

For example, see the `TPaveText::title` context menu. A `TPaveText` inherits from `TAttLine`, which has the method `SetLineAttributes()`.

Adding Context Menus for a Class

For a method to appear in the context menu of the object it has to be marked by `// *MENU*` in the header file. Below is the line from `TAttLine.h` that adds the `SetLineAttribute` method to the context menu.

```
virtual void SetLineAttributes(); // *MENU*
```

Nothing else is needed, since CINT knows the classes and their methods. It takes advantage of that to create the context menu on the fly when the object is clicking on.

If you click on an axis, ROOT will ask the interpreter what are the methods of the `TAxis` and which ones are set for being displayed in a context menu.

Now, how does the interpreter know this? Remember, when you build a class that you want to use in the ROOT environment, you use `rootcint` that builds the so-called stub functions and the dictionary. These functions and the dictionary contain the knowledge of the used classes. To do this, `rootcint` parses all the header files.

ROOT has defined some special syntax to inform CINT of certain things, this is done in the comments so that the code still compiles with a C++ compiler.

For example, you have a class with a `Draw()` method, which will display itself. You would like a context menu to appear when on clicks on the image of an object of this class. The recipe is the following:

1. The class has to contain the `ClassDef/ClassImp` macros
2. For each method you want to appear in the context menu, put a comment after the declaration containing `*MENU*` or `*TOGGLE*` depending on the behavior you expect. One usually uses `Set` methods (setters).

For example:

```
class MyClass : public TObject
{
private :
    int    fV1;    // first variable
    double fV2;    // second variable
public :
    int    GetV1() {return fV1;}
    double GetV2() {return fV2;}
    void   SetV1(int x1) { fV1 = x1;}    // *MENU*
    void   SetV2(double d2) { fV2 = d2;} // *MENU*
    void   SetBoth(int x1, double d2) {fV1 = x1; fV2 = d2;}
    ClassDef (MyClass,1)
}
```

The `*TOGGLE*` comment is used to toggle a `boolean` data field. In that case, it is safe to call the data field `fMyBool` where `MyBool` is the name of the setter `SetMyBool`. Replace `MyBool` with your own `boolean` variable.

3. You can specify arguments and the data members in which to store the arguments.

For example:

```
void SetXXX(Int_t x1, Float_t y2); //*MENU* *ARGS={x1=>fV1}
```

This statement is in the comment field, after the *MENU*. If there is more than one argument, these arguments are separated by commas, where fX1 and fY2 are data fields in the same class.

```
void SetXXX(Int_t x1, Float_t y2); //*MENU* *ARGS={x1=>fX1,y2=>fY2}
```

If the arguments statement is present, the option dialog displayed when selecting SetXXXfield will show the values of variables. We indicate to the system which argument corresponds to which data member of the class.

Executing Events when a Cursor Passes on Top of an Object

This paragraph is for class designers. When a class is designed, it is often desirable to include drawing methods for it. We will have a more extensive discussion about this, but drawing an object in a canvas or a pad consists in "attaching" the object to that pad. When one uses `object.Draw()`, the object is NOT painted at this moment. It is only attached to the active pad or canvas.

Another method should be provided for the object to be painted, the `Paint()` method. This is all explained in the next paragraph.

As well as `Draw()` and `Paint()`, other methods may be provided by the designer of the class. When the mouse is moved or a button pressed/released, the `TCanvas` function named `HandleInput()` scans the list of objects in all its pads and for each object calls some standard methods to make the object react to the event (mouse movement, click or whatever).

The second one is `DistanceToPrimitive(px,py)`. This function computes a "distance" to an object from the mouse position at the pixel position (`px,py`, see definition at the end of this paragraph) and returns this distance in pixel units. The selected object will be the one with the shortest computed distance. To see how this works, select the "Event Status" item in the canvas "Options" menu. ROOT will display one status line showing the picked object. If the picked object is, for example, a histogram, the status line indicates the name of the histogram, the position `x,y` in histogram coordinates, the channel number and the channel content.

It is nice for the canvas to know what the closest object from the mouse is, but it's even nicer to be able to make this object react. The third standard method to be provided is `ExecuteEvent()`. This method actually does the event reaction.

Its prototype is where `px` and `py` are the coordinates at which the event occurred, except if the event is a key press, in which case `px` contains the key code.

```
void ExecuteEvent(Int_t event, Int_t px, Int_t py);
```

Where `event` is the event that occurs and is one of the following (defined in `Buttons.h`):

```
kNoEvent,          kButton1Down,      kButton2Down,      kButton3Down,
kKeyDown,          kButton1Up,        kButton2Up,        kButton3Up,
kButton1Motion,    kButton2Motion,    kButton3Motion,    kKeyPress,
kButton1Locate,    kButton2Locate,    kButton3Locate,    kKeyUp,
kButton1Double,    kButton2Double,    kButton3Double,    kMouseMotion,
kMouseEnter,       kMouseLeave
```

We hope the names are self-explanatory.

Designing an `ExecuteEvent` method is not very easy, except if one wants very basic treatment. We will not go into that and let the reader refer to the sources of classes like `TLine` or `TBox`. Go and look at their `ExecuteEvent` method!

We can nevertheless give some reference to the various actions that may be performed. For example, one often wants to change the shape of the cursor when passing on top of an object. This is done with the `SetCursor` method:

```
gPad->SetCursor(cursor)
```

The argument `cursor` is the type of cursor. It may be:

```
kBottomLeft, kBottomRight, kTopLeft, kTopRight, kBottomSide,
kLeftSide, kTopSide, kRightSide, kMove, kCross,
kArrowHor, kArrowVer, kHand, kRotate, kPointer,
kArrowRight, kCaret, kWatch
```

They are defined in `TVirtualX.h` and again we hope the names are self-explanatory. If not, try them by designing a small class. It may derive from something already known like `TLine`.

Note that the `ExecuteEvent()` functions may in turn; invoke such functions for other objects, in case an object is drawn using other objects. You can also exploit at best the virtues of inheritance. See for example how the class `TArrow` (derived from `TLine`) use or redefine the picking functions in its base class.

The last comment is that mouse position is always given in pixel units in all these standard functions. `px=0` and `py=0` corresponds to the top-left corner of the canvas. Here, we have followed the standard convention in windowing systems. Note that user coordinates in a canvas (pad) have the origin at the bottom-left corner of the canvas (pad). This is all explained in the paragraph "Coordinate system of a pad".

Graphical Containers: Canvas and Pad

We have talked a lot about canvases, which may be seen as windows. More generally, a graphical entity that contains graphical objects is called a Pad. A Canvas is a special kind of Pad. From now on, when we say something about pads, this also applies to canvases. A pad (class `TPad`) is a graphical container in the sense it contains other graphical objects like histograms and arrows. It may contain other pads (sub-pads) as well. More technically, each pad has a linked list of pointers to the objects it holds.

Drawing an object is nothing more than adding its pointer to this list. Look for example at the code of `TH1::Draw()`. It is merely ten lines of code. The last statement is `AppendPad()`. This statement calls a method of `TObject` that just adds the pointer of the object, here a histogram, to the list of objects attached to the current pad. Since this is a `TObject`'s method, every object may be "drawn", which means attached to a pad.

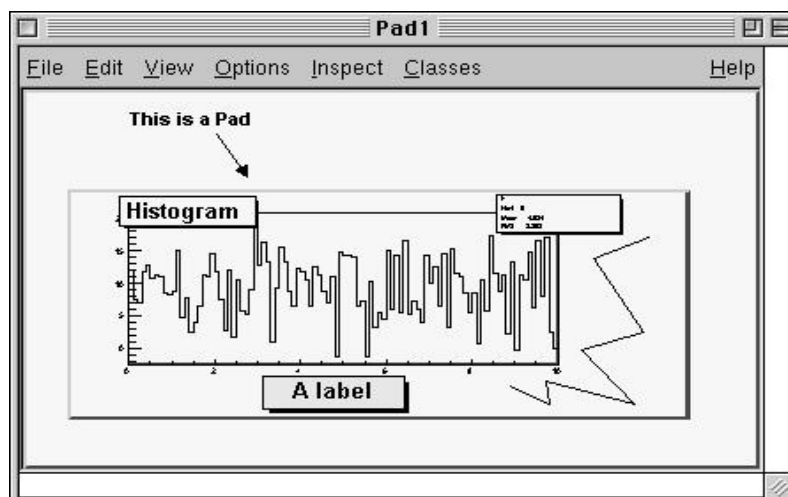

We can illustrate this by the following figure.

The image corresponding to this structure:

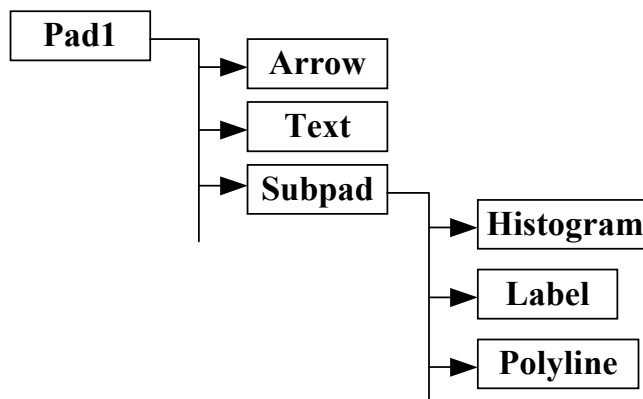

When is the painting done then? The answer is: when needed. Every object that derives from `TObject` has a `Paint()` method. It may be empty, but for graphical objects, this routine contains all the instructions to effectively paint it in the active pad. Since a Pad has the list of objects it owns, it will call successively the `Paint()` method of each object, thus re-painting the whole pad on the screen. If the object is a sub-pad, its `Paint()` method will call the `Paint()` method of the objects attached, recursively calling `Paint()` for all the objects.

The Global Pad: `gPad`

When an object is drawn, it is always in the so-called active pad. For every day use, it is comfortable to be able to access the active pad, whatever it is. For that purpose, there is a global pointer, called `gPad`. It is always pointing to the active pad. If you want to change the fill color of the active pad to blue but you don't know its name, do this.

```
root[] gPad->SetFillColor(38)
```

To get the list of colors, go to the paragraph "Color and color palettes" or if you have an opened canvas, click on the `View` menu, selecting the `Colors` item.

Finding an Object in a Pad

Now that we have a pointer to the active pad, `gPad` and that we know this pad contains some objects, it is sometimes interesting to access one of those objects. The method `GetPrimitive()` of `TPad`, i.e. `TPad::GetPrimitive(const char* name)` does exactly this. Since most of the objects that a pad contains derive from `TObject`, they have a name. The following statement will return a pointer to the object `myobjectname` and put that pointer into the variable `obj`. As you see, the type of returned pointer is `(TObject*)`.

```
root[] obj = gPad->GetPrimitive("myobjectname")
(class TObject*)0x1063cba8
```

Even if your object is something more complicated, like a histogram `TH1F`, this is normal. A function cannot return more than one type. So the one chosen was the lowest common denominator to all possible classes, the class from which everything derives, `TObject`. How do we get the right pointer then? Simply do a cast of the function output that will transform the output (pointer) into the right type. For example if the object is a `TPaveLabel`:

```
root[] obj = (TPaveLabel*)(gPad->GetPrimitive("myobjectname"))
(class TPaveLabel*)0x1063cba8
```

This works for all objects deriving from `TObject`. However, a question remains. An object has a name if it derives from `TNamed`, not from `TObject`. For example, an arrow (`TArrow`)

doesn't have a name. In that case, the "name" is the name of the class. To know the name of an object, just click with the right button on it. The name appears at the top of the context menu. In case of multiple unnamed objects, a call to `GetPrimitive("className")` returns the instance of the class that was first created. To retrieve a later instance you can use `GetListOfPrimitives()`, which returns a list of all the objects on the pad. From the list you can select the object you need.

Hiding an Object

Hiding an object in a pad can be made by removing it from the list of objects owned by that pad. This list is accessible by the `GetListOfPrimitives()` method of `TPad`. This method returns a pointer to a `TList`. Suppose we get the pointer to the object, we want to hide, call it `obj` (see paragraph above). We get the pointer to the list:

```
root[] li = gPad->GetListOfPrimitives()
```

Then remove the object from this list:

```
root[] li->Remove(obj)
```

The object will disappear from the pad as soon as the pad is updated (try to resize it for example).

If one wants to make the object reappear:

```
root[] obj->Draw()
```

Caution, this will not work with composed objects, for example many histograms drawn on the same plot (with the option "same"). There are other ways! Try to use the method described here for simple objects.

The Coordinate Systems of a Pad

Three coordinate systems may be used in a `TPad`: pixel coordinates, normalized coordinates (NDC), and user coordinates.

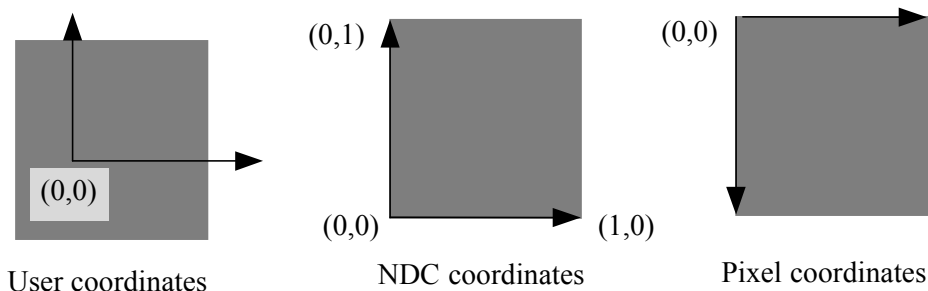

The User Coordinate System

The most common is the user coordinate system. Most methods of `TPad` use the user coordinates, and all graphic primitives have their parameters defined in terms of user coordinates. By default, when an empty pad is drawn, the user coordinates are set to a range from 0 to 1 starting at the lower left corner. At this point they are equivalent of the NDC coordinates (see below). If you draw a high level graphical object, such as a histogram or a function, the user coordinates are set to the coordinates of the histogram. Therefore, when you set a point it will be in the histogram coordinates

For a newly created blank pad, one may use `TPad::Range` to set the user coordinate system. This function is defined as:

```
void Range(float x1, float y1, float x2, float y2)
```

The arguments `x1`, `x2` defines the new range in the x direction, and the `y1`, `y2` define the new range in the y-direction.

```
root[] TCanvas MyCanvas ("MyCanvas")
root[] gPad->Range (-100, -100, 100, 100)
```

This will set the active pad to have both coordinates to go from -100 to 100, with the center of the pad at (0,0). You can visually check the coordinates by viewing the status bar in the canvas. To display the status bar select `Options:Event Status` in the canvas menu.



The Normalized Coordinate System (NDC)

Normalized coordinates are independent of the window size and of the user system. The coordinates range from 0 to 1 and (0, 0) corresponds to the bottom-left corner of the pad. Several internal ROOT functions use the NDC system (3D primitives, PostScript, log scale mapping to linear scale). You may want to use this system if the user coordinates are not known ahead of time.

The Pixel Coordinate System

The least common is the pixel coordinate system, used by functions such as `DistanceToPrimitive()` and `ExecuteEvent()`. Its primary use is for cursor position, which is always given in pixel coordinates. If (px, py) is the cursor position, $px=0$ and $py=0$ corresponds to the top-left corner of the pad, which is the standard convention in windowing systems.

Using NDC for a particular Object

Most of the time, you will be using the user coordinate system. But sometimes, you will want to use NDC. For example, if you want to draw text always at the same place over a histogram, no matter what the histogram coordinates are. There are two ways to do this. You can set the NDC for one object or may convert NDC to user coordinates. Most graphical objects offer an option to be drawn in NDC. For instance, a line (`TLine`) may be drawn in NDC by using `DrawLineNDC()`. A latex formula or a text may use `TText::SetNDC()` to be drawn in NDC coordinates.

Converting between Coordinates Systems

There are a few utility functions in `TPad` to convert from one system of coordinates to another. In the following table, a point is defined by (px, py) in pixel coordinates; (ux, uy) in user coordinates, $(ndcx, ndcy)$ in NDC coordinates.

Conversion	Methods of <code>TPad</code>	Returns
Pixel to User	<code>PixeltoX(px)</code>	double
	<code>PixeltoY(py)</code>	double
	<code>PixeltoXY(px, py, &ux, &uy)</code>	changes <code>ux, uy</code>
NDC to Pixel	<code>UtoPixel(ndcx)</code>	int
	<code>VtoPixel(ndcy)</code>	int
User to Pixel	<code>XtoPixel(ux)</code>	int
	<code>YtoPixel(uy)</code>	int
	<code>XYtoPixel(ux, uy, &px, &py)</code>	changes <code>px, py</code>

Dividing a Pad into Sub-pads

Dividing a pad into sub pads in order for instance to draw a few histograms, may be done in two ways. The first is to build pad objects and to draw them into a parent pad, which may be a canvas. The second is to automatically divide a pad into horizontal and vertical sub pads.

Creating a Single Sub-pad

The simplest way to divide a pad is to build sub-pads in it. However, this forces the user to explicitly indicate the size and position of those sub-pads. Suppose we want to build a sub-pad in the active pad (pointed by *gPad*). First, we build it, using a *TPad* constructor:

```
root[] spad1 = new TPad("spad1","The first subpad",.1,.1,.5,.5)
```

One gives the coordinates of the lower left point (0.1, 0.1) and of the upper right one (0.5, 0.5). These coordinates are in NDC. This means that they are independent of the user coordinates system, in particular if you have already drawn for example a histogram in the mother pad.

The only thing left is to draw the pad:

```
root[] spad1->Draw()
```

If you want more sub-pads, you have to repeat this procedure as many times as necessary.

Dividing a Canvas into Sub-Pads

The manual way of dividing a pad into sub-pads is sometimes very tedious. There is a way to automatically generate horizontal and vertical sub-pads inside a given pad.

```
root[] pad1->Divide(3,2)
```

If *pad1* is a pad then, it will divide the pad into 3 columns of 2 sub-pads:

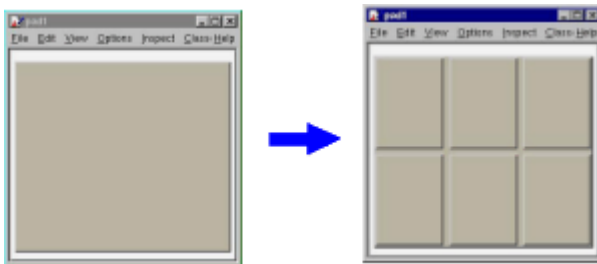

The generated sub-pads get names *pad1_i* where *i* is 1 to *nxm*. In our case *pad1_1*, *pad1_2*... *pad1_6*.

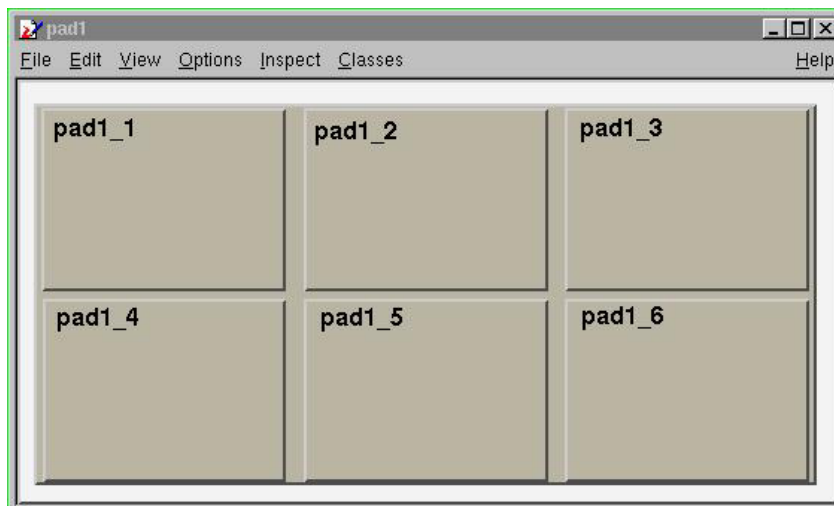

The names *pad1_1* etc... correspond to new variables in CINT, so you may use them as soon as the *pad->Divide()* was executed. However, in a compiled program, one has to access these objects. Remember that a pad contains other objects and that these objects may, themselves be pads. So we can use the *GetPrimitive()* method of *TPad*:

```
TPad* pad1_1 = (TPad*)(pad1->GetPrimitive("pad1_1"))
```

One question remains. In case one does an automatic divide, how can one set the default margins between pads? This is done by adding two parameters to `Divide()`, which are the margins in `x` and `y`:

```
root[] pad1->Divide(3,2,0.1,0.1)
```

The margins are here set to 10% of the parent pad width.

Updating the Pad

For performance reasons, a pad is not updated with every change. For example, changing the coordinates of the pad does not automatically redraw it. Instead, the pad has a "bit-modified" that triggers a redraw.

This bit is automatically set by:

1. Touching the pad with the mouse. For example resizing it with the mouse.
2. Finishing the execution of a script.
3. Adding a new primitive or modifying some primitives for example the name and title of an object.

You can also set the "bit-modified" explicitly with the `Modified` method:

```
// the pad has changed
root[] pad1->Modified()
// recursively update all modified pads:
root[] c1->Update()
```

A subsequent call to `TCanvas->Update()` scans the list of sub-pads and repaints the pads declared modified.

In compiled code or in a long macro, you may want to access an object created during the paint process. To do so, you can force the painting with a `TCanvas::Update()`. For example a `TGraph` creates a histogram (`TH1`) to paint itself. In this case the internal histogram obtained with `TGraph::GetHistogram()` is created only after the pad is painted. The pad is painted automatically after the script is finished executing or if you force the painting with `TPad::Modified` followed by a `TCanvas::Update`.

Note that it is not necessary to call `TPad::Modified` after a call to `Draw()`. The "bit-modified" is set automatically by `Draw()`.

A note about the "bit-modified" in sub pads: when you want to update a sub pad in your canvas, you need to call `pad->Modified` rather than `canvas->Modified`, and follow it with a `canvas->Update`. If you use `canvas->Modified`, followed by a call to `canvas->Update`, the sub pad has not been declared modified and it will not be updated.

Also note that a call to `pad->Update` where `pad` is a sub pad of canvas, calls `canvas->Update` and recursively updates all the pads on the canvas.

Making a Pad Transparent

As we will see in the paragraph "Fill attributes", a fill style (type of hatching) may be set for a pad.

```
root[] pad1->SetFillStyle(istyle)
```

This is done with the `SetFillStyle` method where `istyle` is a style number, defined in "Fill attributes".

A special set of styles allows handling of various levels of transparency. These are styles number 4000 to 4100, 4000 being fully transparent and 4100 fully opaque.

So, suppose you have an existing canvas with several pads. You create a new pad (transparent) covering for example the entire canvas. Then you draw your primitives in this pad. The same can be achieved with the graphics editor.

For example:

```
root[] .x tutorials/hldraw.C
root[] TPad *newpad=new TPad("newpad","Transparent pad,0,0,1,1);
root[] newpad.SetFillStyle(4000);
root[] newpad.Draw();
root[] newpad.cd();
root[] // create some primitives, etc
```

Setting the Log Scale is a Pad Attribute

Setting the scale to logarithmic or linear is an attribute of the pad, not the axis or the histogram. The scale is an attribute of the pad because you may want to draw the same histogram in linear scale in one pad and in log scale in another pad.

Frequently, we see several histograms on top of each other in the same pad. It would be very inconvenient to set the scale attribute for each histogram in a pad. Furthermore, if the logic was in the histogram class (or each object), one would have to test the scale setting in each `Paint` method of all objects.

If you have a pad with a histogram, a right-click on the pad, outside of the histograms frame will convince you. The `SetLogx()`, `SetLogy()` and `SetLogz()` methods are there. As you see, `TPad` defines log scale for the two directions `x` and `y` plus `z` if you want to draw a 3D representation of some function or histogram.

The way to set log scale in the `x` direction for the active pad is:

```
root[] gPad->SetLogx(1)
```

To reset log in the `z` direction:

```
root[] gPad->SetLogz(0)
```

If you have a divided pad, you need to set the scale on each of the sub-pads. Setting it on the containing pad does not automatically propagate to the sub-pads. Here is an example of how to set the log scale for the `x`-axis on a canvas with four sub-pads:

```
root[] TCanvas MyCanvas("MyCanvas","My Canvas")
root[] MyCanvas->Divide(2,2)
root[] MyCanvas->cd(1)
root[] gPad->SetLogx()
root[] MyCanvas->cd(2)
root[] gPad->SetLogx()
root[] MyCanvas->cd(3)
root[] gPad->SetLogx()
```

WaitPrimitive method

When the `TPad::WaitPrimitive()` is called with no arguments, it will wait until a double click or any key pressed is executed in the canvas. A call to `gSystem->Sleep(10)` has been added in the loop to avoid consuming at all the CPU. This new option is convenient when executing a macro. By adding statements like:

```
canvas->WaitPrimitive();
```

you can monitor the progress of a running macro, stop it at convenient places with the possibility to interact with the canvas and resume the execution with a double click or a key press.

Locking the Pad

You can make the `TPad` non-editable. Then no new objects can be added, and the existing objects and the pad can not be changed with the mouse or programmatically.

```
TPad::SetEditable(kFALSE)
```

By default the `TPad` is editable.

Graphical Objects

In this paragraph, we describe the various simple 2D graphical objects defined in ROOT. Usually, one defines these objects with their constructor and draws them with their `Draw()` method. Therefore, the examples will be very brief. Most graphical objects have line and fill attributes (color, width) that will be described in "Graphical objects attributes".

If the user wants more information, the class names are given and he may refer to the online developer documentation. This is especially true for functions and methods that set and get internal values of the objects described here.

By default 2D graphical objects are created in User Coordinates with (0,0) in the lower left corner.

Lines, Arrows, and Geometrical Objects

Line: Class `TLine`

The simplest graphical object is a line. It is implemented in the `TLine` class. The constructor is:

```
TLine(Double_t x1, Double_t y1, Double_t x2, Double_t y2)
```

The arguments `x1`, `y1`, `x2`, `y2` are the coordinates of the first and second point. This constructor may be used as in:

```
root[] l = new TLine(0.2, 0.2, 0.8, 0.3)
root[] l->Draw()
```

Arrows: Class `TArrow`

Different arrow formats as shown in the next picture are available.

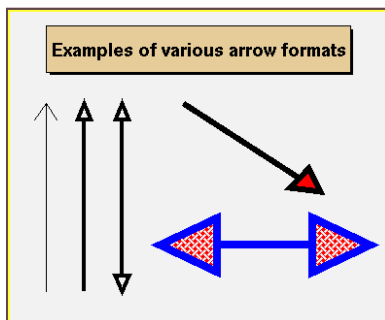

Once an arrow is drawn on the screen, one can:

- click on one of the edges and move this edge.
- click on any other arrow part to move the entire arrow.

The constructor is:

```
TArrow(Double_t x1, Double_t y1, Double_t x2, Double_t y2,
        Float_t arrowsize, Option_t *option)
```

It defines an arrow between points $x1, y1$ and $x2, y2$. The arrow size is in percentage of the pad height.

The options are the following:

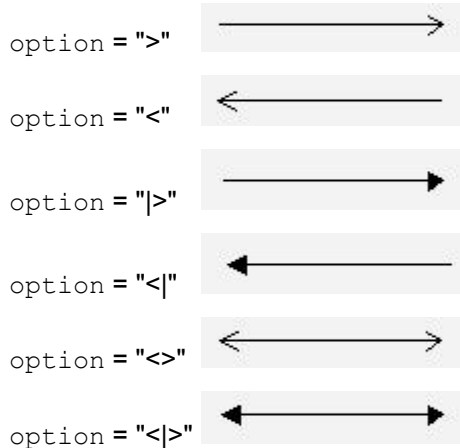

If `FillColor == 0`, draw open triangle else draw full triangle with fill color. If `ar` is an arrow object, fill color is set with:

```
ar.SetFillColor(icolor);
```

Where `icolor` is the color defined in "Color and color palettes".

The opening angle between the two sides of the arrow is 60 degrees. It can be changed with `ar->SetAngle(angle)`, where `angle` is expressed in degrees.

Poly-line: Class *TPolyLine*

A poly-line is a set of joint segments. It is defined by a set of `N` points in a 2D space. Its constructor is:

```
TPolyLine(Int_t n, Double_t* x, Double_t* y, Option_t* option)
```

Where `n` is the number of points, and `x` and `y` are arrays of `n` elements with the coordinates of the points. `TPolyLine` can be used by it self, but is also a base class for other objects, such as curly arcs.

Circles, Ellipses: Class *TEllipse*

Ellipse is a general ellipse that can be truncated and rotated. An ellipse is defined by its center $(x1, y1)$ and two radii `r1` and `r2`. A minimum and maximum angle may be specified (`phimin`, `phimax`). The picture below illustrates different types of ellipses:

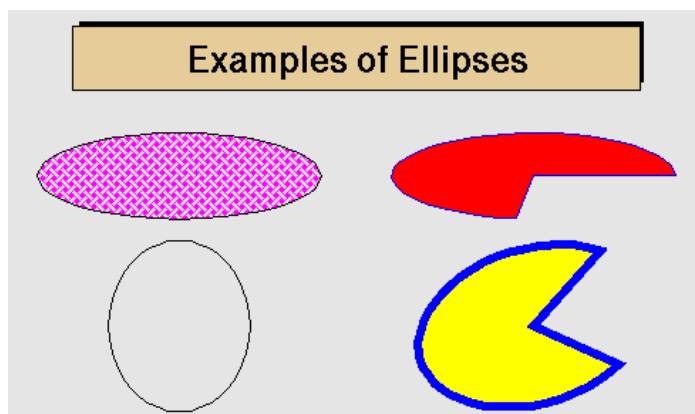

The Ellipse may be rotated with an angle `theta`. The attributes of the outline line and of the fill area are described in "Graphical objects attributes"

The constructor of a **TEllipse** object is:

```
TEllipse(Double_t x1,Double_t y1,Double_t r1,Double_t r2,  
         Double_t phimin,Double_t phimax,Double_t theta)
```

An ellipse may be created with a statement like:

```
root[] e = new TEllipse(0.2,0.2,0.8,0.3)  
root[] e->Draw()
```

Rectangles: Classes *TBox* and *TWbox*

A rectangle is defined by the class **TBox** since it is a base class for many different higher-level graphical primitives. A box is defined by its bottom left coordinates x_1, y_1 and its top right coordinates x_2, y_2 .

The constructor is:

```
TBox(Double_t x1,Double_t y1,Double_t x2,Double_t y2)
```

It may be used as in:

```
root[] b = new TBox(0.2,0.2,0.8,0.3)  
root[] b->Draw()
```

A **TWbox** is a rectangle (**TBox**) with a border size and a border mode:

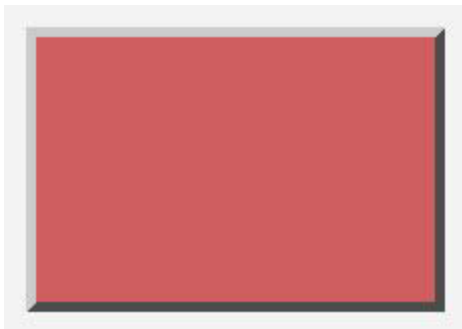

The attributes of the outline line and of the fill area are described in “Graphical Objects Attributes”

One Point, or Marker: Class *TMarker*

A marker is a point with a fancy shape! The possible markers are the following:

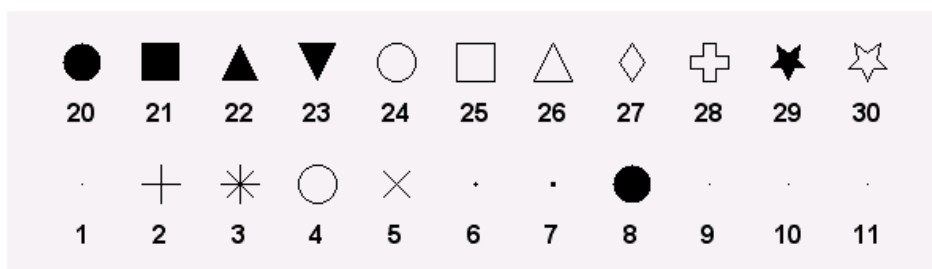

One marker is build via the constructor:

```
TMarker(Double_t x,Double_t y,Int_t marker)
```

The parameters x and y are the coordinates of the marker and `marker` is the type, shown above. Suppose `ma` is a valid marker. One can set the size of the marker with `ma->SetMarkerSize(size)`, where `size` is the desired size.

The available sizes are:

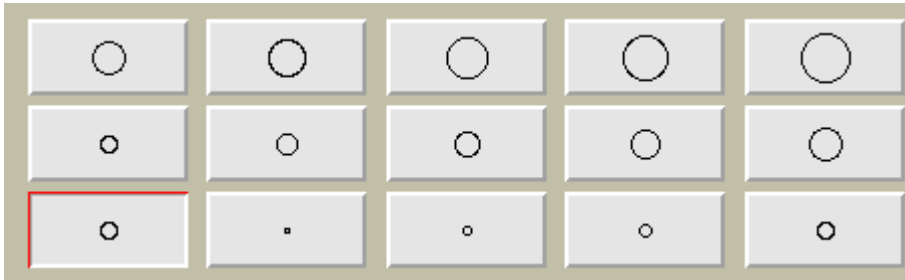

It can be specified sizes smaller than 1.

Set of Points: Class *TPolyMarker*

A **TPolyMaker** is defined by an array on N points in a 2D space. At each point $x[i]$, $y[i]$ a marker is drawn. The list of marker types is shown in the previous paragraph.

The marker attributes are managed by the class **TAttMarker** and are described in "Graphical objects attributes"

The constructor for a **TPolyMarker** is:

```
TPolyMarker(Int_t n, Double_t *x, Double_t *y, Option_t *option)
```

Where x and y are arrays of coordinates for the n points that form the poly-marker.

Curly and Wavy Lines for Feynman Diagrams

This is a peculiarity of particle physics, but we do need sometimes to draw Feynman diagrams. Our friends working in banking can skip this part.

A set of classes implements curly or wavy poly-lines typically used to draw Feynman diagrams. Amplitudes and wavelengths may be specified in the constructors, via commands or interactively from context menus. These classes are **TCurlyLine** and **TCurlyArc**.

These classes make use of **TPolyLine** by inheritance; `ExecuteEvent` methods are highly inspired from the methods used in **TPolyLine** and **TArc**.

The picture below has been generated by the tutorial `feynman.C`:

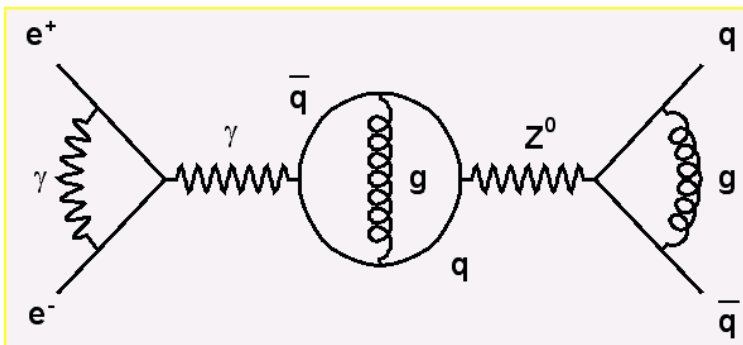

The constructor is:

```
TCurlyLine(Double_t x1, Double_t y1, Double_t x2, Double_t y2,
            Double_t wavelength, Double_t amplitude)
```

With the starting point $(x1, y1)$, end point $(x2, y2)$. The wave length and amplitude are given in percent of the pad height.

For `TCurlyArc`, the constructor is:

```
TCurlyArc(Double_t x1,Double_t y1,Double_t rad,Double_t phimin,
          Double_t phimax,Double_t wavelength,Double_t amplitude)
```

The center is (x_1, y_1) and the radius `rad`. The wave length and the amplitude are given in percent of the line length, `phimin` and `phimax`, which are the starting and ending angle of the arc, are given in degrees. Refer to `$ROOTSYS/tutorials/feynman.C` for the script that built the picture above.

Text and Latex Mathematical Expressions

Text displayed in a pad may be embedded into boxes, called `paves` (such as `PaveLabels`), or titles of graphs or many other objects but it can live a life of its own. All text displayed in ROOT graphics is an object of class `TText`. For a physicist, it will be most of the time a `TLatex` expression (which derives from `TText`). `TLatex` has been conceived to draw mathematical formulae or equations. Its syntax is very similar to the Latex one *in mathematical mode*.

Subscripts and Superscripts

Subscripts and superscripts are made with the `_` and `^` commands. These commands can be combined to make complicated subscript and superscript expressions. You may choose how to display subscripts and superscripts using the 2 functions `SetIndiceSize(Double_t)` and `SetLimitIndiceSize(Int_t)`. Examples of what can be obtained using subscripts and superscripts:

The expression	Gives	The expression	Gives	The expression	Gives
<code>x^{2y}</code>	x^{2y}	<code>x^{y^{2}}</code>	x^{y^2}	<code>x^{y}_{1}</code>	x_1^y
<code>x_{2y}</code>	x_{2y}	<code>x^{y}_{1}</code>	x^{y_1}	<code>x_{1}^{y}</code>	x_1^y

Fractions

Fractions denoted by the `/` symbol are made in the obvious way. The `#frac` command is used for large fractions in displayed formula; it has two arguments: the numerator and the denominator. For example, this equation is obtained by following expression.

$$x = \frac{y+z/2}{y^2+1}$$

```
x=#frac{y+z/2}{y^{2}+1}
```

Roots

The `#sqrt` command produces the square ROOT of its argument; it has an optional first argument for other roots.

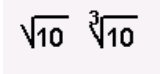
Example: `#sqrt{10}` `#sqrt[3]{10}` 

Delimiters

You can produce three kinds of proportional delimiters.

`#[]{...}` or "a la" Latex

`#left[...#right]`: big square brackets

`#{}{...}` or `#left{...#right}`: big curly brackets

`#||{...}` or `#left|...#right|`: big absolute value symbol

`#(){...}` or `#left(...#right)`: big parenthesis

Greek Letters

The command to produce a lowercase Greek letter is obtained by adding # to the name of the letter. For an uppercase Greek letter, just capitalize the first letter of the command name.

#alpha	#beta	#gamma	#delta	#epsilon	#zeta	#eta	#theta
#iota	#kappa	#lambda	#mu	#nu	#xi	#omicron	#pi
#varpi	#rho	#sigma	#tau	#upsilon	#phi	#varphi	#chi
#psi	#omega	#Gamma	#Delta	#Theta	#Lambda	#Xi	#Pi
#Sigma	#Upsilon	#Phi	#Psi	#Omega			

Changing Style in Math Mode

You can change the font and the text color at any moment using:

#font[font-number]{...} and #color[color-number]{...}

Mathematical Symbols

T**I****a****t****e****x** can make mathematical and other symbols. A few of them, such as + and >, are produced by typing the corresponding keyboard character. Others are obtained with the commands in the following table.

≤ #leq	/ #l	∞ #infty	> #GT
♣ #club	♦ #diamond	♥ #heart	♠ #spade
↔ #leftrightarrow	← #leftarrow	↑ #uparrow	→ #rightarrow
↓ #downarrow	° #circ	± #pm	" #doublequote
≥ #geq	× #times	∞ #propto	∂ #partial
• #bullet	÷ #divide	≠ #neq	≡ #equiv
≈ #approx	⋯ #3dots	#cbar	— #topbar
↙ #downleftarrow	ℵ #aleph	ℑ #Jgothic	℔ #Rgothic
⊙ #odot	⊗ #otimes	⊕ #oplus	⊘ #oslash
∩ #cap	∪ #cup	⊃ #supset	⊇ #supseteq
⊄ #notsubset	⊂ #subset	⊆ #subseteq	∈ #in
∉ #notin	∠ #angle	∇ #nabla	® #oright
© #copyright	™ #trademark	∏ #prod	√ #surd
· #upoint	┐ #corner	∧ #wedge	∨ #vee
⇔ #Leftrightarrow	⇐ #Leftarrow	⇑ #Uparrow	⇒ #Rrightarrow
⇓ #Downarrow	◆ #diamond	⟨ #LT	□ #Box
© #copyright	™ #void3	∑ #sum	∅ #voidn
#lbar	⏟ #arcbottom	— #topbar	⌒ #arctop
⏟ #bottombar	⌒ #arcbar	{ #lbar	∫ #int
∥ #parallel	⊥ #perp	> #GT	∫ #voidb

Accents, Arrows and Bars

Symbols in a formula are sometimes placed one above another. **T****I****a****t****e****x** provides special commands for doing this.

#hat{a}	= hat
#check	= inverted hat
#acute	= acute
#grave	= accent grave
#dot	= derivative
#ddot	= double derivative
#tilde	= tilde
#slash	= special sign. Draw a slash on top of the text between brackets for example #slash{E}_T generates "Missing ET"
\bar{a}	Is obtained with #bar{a}
\vec{a}	Is obtained with #vec{a}

Example 1

The following script (\$ROOTSYS/tutorials/latex.C)

```
{
gROOT->Reset();
TCanvas c1("c1","Latex",600,700);
TLatex l;
l.SetTextAlign(12);
l.SetTextSize(0.04);
l.DrawLatex(0.1,0.8,"1) C(x) = d #sqrt{#frac{2}{#lambdaD}}
#int^{x}_{0}cos(#frac{#pi}{2}t^{2})dt");
l.DrawLatex(0.1,0.6,"2) C(x) = d #sqrt{#frac{2}{#lambdaD}}
#int^{x}cos(#frac{#pi}{2}t^{2})dt");
l.DrawLatex(0.1,0.4,"3) R = |A|^{2} =
#frac{1}{2} (#[]{#frac{1}{2}+C(V)}^{2}+
#[]{#frac{1}{2}+S(V)}^{2})");
l.DrawLatex(0.1,0.2,"4) F(t) = #sum_{i=
-#infty}^{#infty}A(i)cos#[]{#frac{i}{t+i}}");
}
```

The script makes this picture:

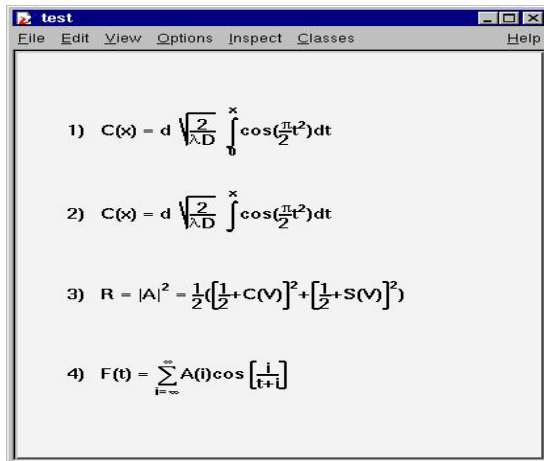

Example 2

The following script (\$ROOTSYS/tutorials/latex2.C) :

```
{
gROOT->Reset();
TCanvas c1("c1","Latex",600,700);
TLatex l;
l.SetTextAlign(23);
l.SetTextSize(0.1);
l.DrawLatex(0.5,0.95,"e^{+}e^{-}#rightarrowZ^{0}
#rightarrowI#bar{I}, q#bar{q}");
l.DrawLatex(0.5,0.75,"|#vec{a}#bullet#vec{b}|=
#Sigma^{i}_{jk}+b^{bj}_{i}");
l.DrawLatex(0.5,0.5,"i (#partial_{#mu}#bar{#psi}#gamma^{#mu}
+m#bar{#psi})=0
#Leftrightarrow(#Box+m^{2})#psi=0");
l.DrawLatex(0.5,0.3,"L_{em}=eJ^{#mu}_{em}A_{#mu} ,
J^{#mu}_{em}=#bar{I}#gamma_{#mu}I
M^{j}_{i}=#SigmaA_{#alpha}#tau^{#alpha}_{j}_{i}");
}
```

The result is the following picture:

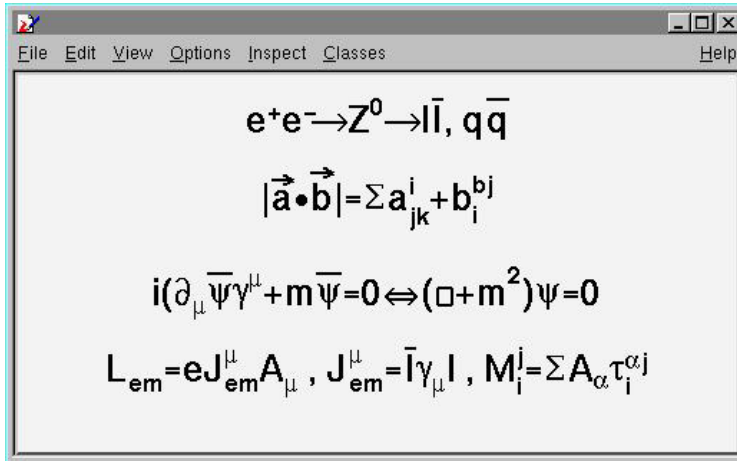

Example 3

The following script (\$ROOTSYS/tutorials/latex3.C):

```
{
gROOT->Reset();
TCanvas c1("c1");
TPaveText pt(.1,.5,.9,.9);
pt.AddText("#frac{2s}{#pi#alpha^2}
#frac{d#sigma}{d#cos#theta} (e^+e^-
#rightarrow f#bar{f}) = ");
pt.AddText("#left| #frac{1}{1 - #Delta#alpha} #right|^2
(1+cos^2)#theta");
pt.AddText("#+ 4 Re #left{ #frac{2}{1 - #Delta#alpha} #chi(s)
#[[]#{#hat{g}}_{#nu}^{#e}#hat{g}_{#nu}^{#f}
(1 + cos^2)#theta) + 2 #hat{g}_{#a}^{#e}
#hat{g}_{#a}^{#f} cos#theta) } #right");
pt.SetLabel("Born equation");
pt.Draw();
}
```

The result is the following picture:

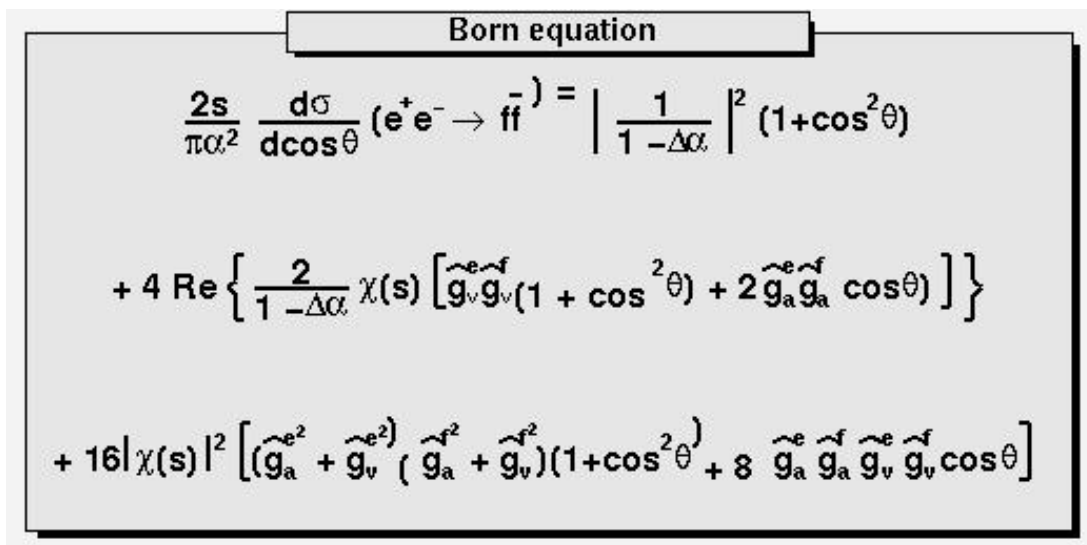

Text in Labels and TPaves

Text displayed in a pad may be embedded into boxes, called paves, or may be drawn alone. In any case, it is recommended to use a Latex expression, which is covered in the previous paragraph. Using `\LaTeX` is valid whether the text is embedded or not. In fact, you will use Latex expressions without knowing it since it is the standard for all the embedded text.

A pave is just a box with a border size and a shadow option. The options common to all types of paves and used when building those objects are the following:

<code>option = "T"</code>	top frame
<code>option = "B"</code>	bottom frame
<code>option = "R"</code>	right frame
<code>option = "L"</code>	left frame
<code>option = "NDC"</code>	<code>x1, y1, x2, y2</code> are given in NDC
<code>option = "ARC"</code>	corners are rounded

We will see the practical use of these options in the description of the more functional objects like `TPaveLabels`.

There are several categories of paves containing text:

TPaveLabel

`TPaveLabels` are panels containing one line of text. They are used for labeling. The constructor is:

```
TPaveLabel(Double_t x1, Double_t y1, Double_t x2, Double_t y2,  
           const char *label, Option_t *option)
```

Where $(x1, y1)$ are the coordinates of the bottom left corner, $(x2, y2)$ the coordinates of the upper right corner. "label" is the text to be displayed and "option" is the drawing option, described above. By default, the border size is 5 and the option is "br".

If one wants to set the border size to some other value, one may use the method `SetBorderSize()`. For example, suppose we have a histogram, which limits are $(-100, 100)$ in the x direction and $(0, 1000)$ in the y direction.

The following lines will draw a label in the center of the histogram, with no border. If one wants the label position to be independent of the histogram coordinates, or user coordinates, one can use the option "NDC". See the paragraph about coordinate systems for more information.

```
root[] p1 = new TPaveLabel(-50,0,50,200,"Some text")  
root[] p1->SetBorderSize(0)  
root[] p1->Draw()
```

Here are examples of what may be obtained:

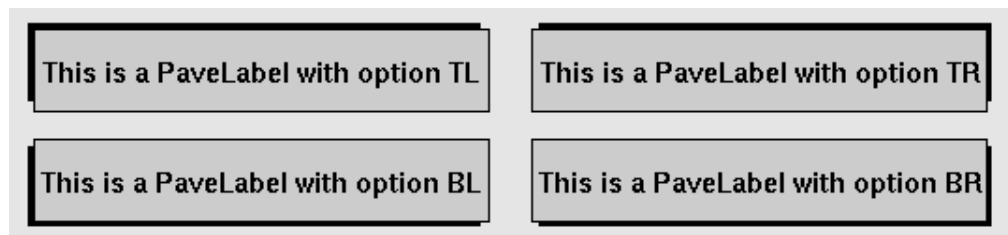

TPaveText

A **TPaveLabel** can contain only one line of text. A **TPaveText** may contain several lines. This is the only difference. This picture illustrates and explains some of the points of **TPaveText**. Once a **TPaveText** is drawn, a line can be added or removed by bringing up the context menu with the mouse.

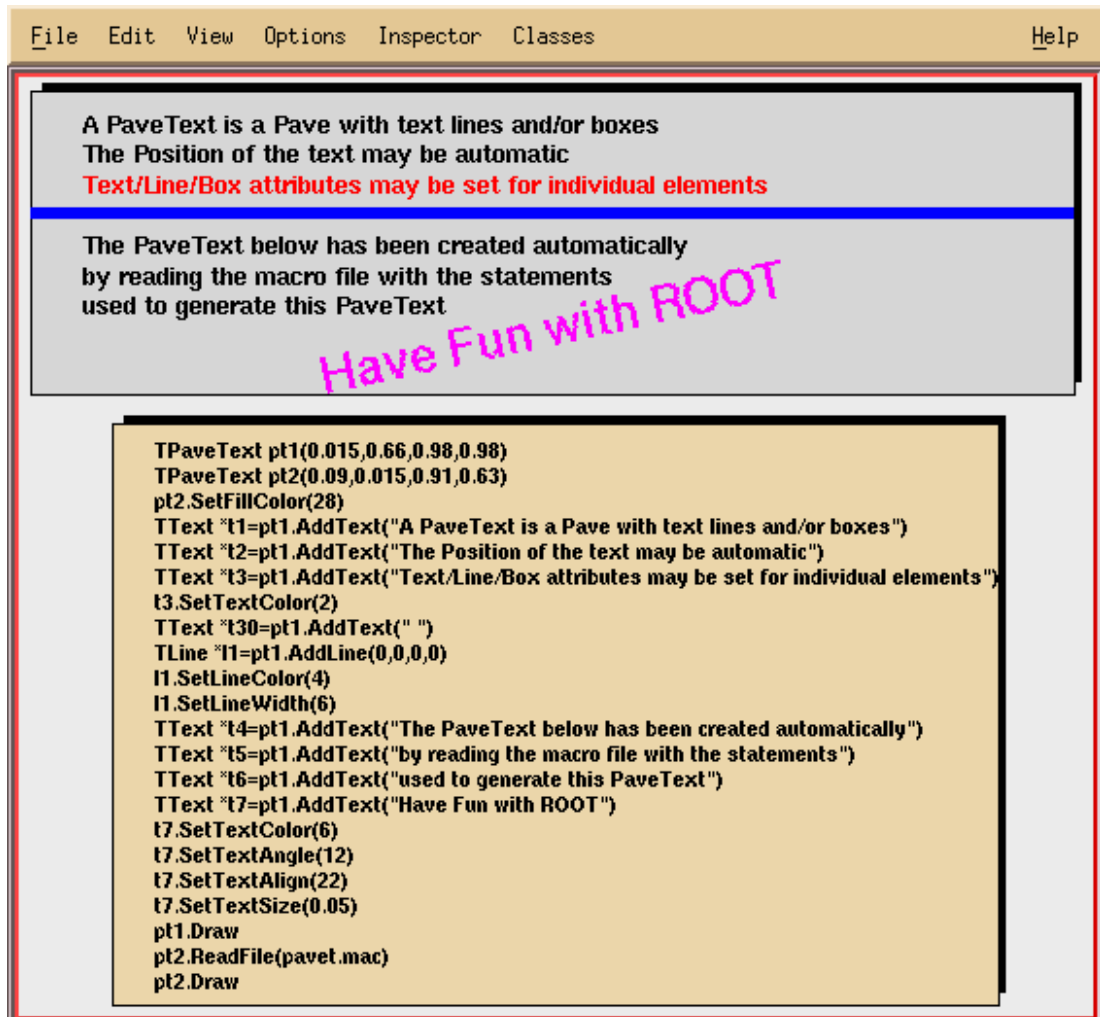

TPavesText

A **TPavesText** is a stack of text panels (see **TPaveText**). One can set the number of stacked panels at building time. It has the following constructor:

```
TPavesText(Double_t x1,Double_t y1,Double_t x2,Double_t y2,
           Int_t npaves,Option_t* option)
```

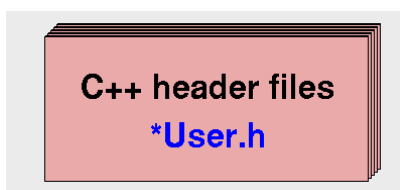

By default, the number of stacked panels is 5 and `option = "br"`.

Sliders

Sliders may be used for showing the evolution of a process or setting the limits of an object's value interactively. A `TSlider` object contains a slider box that can be moved or resized.

Slider drawing options include the possibility to change the slider starting and ending positions or only one of them. The current slider position can be retrieved via the functions `TSlider::GetMinimum()` and `TSlider::GetMaximum()`. These two functions return numbers in the range $[0, 1]$. One may set a C expression to be executed when the mouse button 1 is released. This is done with the `TSlider::SetMethod()` function. It is also possible to reference an object. If no method or C expression has been set, and an object is referenced (`SetObject` has been called), while the slider is being moved/resized, the object `ExecuteEvent` function is called.

Let's see an example using `SetMethod`. The script is called `xyslider.C`. You can find this script in `$ROOTSYS/tutorials`.

```
{
// Example of script featuring two sliders
TFile *f = new TFile("hsimple.root");
TH2F *hpxpy = (TH2F*)f->Get("hpxpy");
TCanvas *c1 = new TCanvas("c1");
TPad *pad = new TPad("pad", "lego pad", 0.1, 0.1, 0.98, 0.98);
pad->SetFillColor(33);
pad->Draw();
pad->cd();
gStyle->SetFrameFillColor(42);
hpxpy->SetFillColor(46);
hpxpy->Draw("lego1");
c1->cd();

// Create two sliders in main canvas. When button1
// of the mouse will be released, action.C will be called
TSlider *xslider = new TSlider("xslider", "x", .1, .02, .98, .08);
xslider->SetMethod(".x action.C");

TSlider *yslider = new TSlider("yslider", "y", .02, .1, .06, .98);
yslider->SetMethod(".x action.C");
}
```

The script that is executed when button 1 is released is the following (script `action.C`):

```
{
  Int_t nx = hpxpy->GetXaxis()->GetNbins();
  Int_t ny = hpxpy->GetYaxis()->GetNbins();
  Int_t binxmin = nx*xslider->GetMinimum();
  Int_t binxmax = nx*xslider->GetMaximum();
  hpxpy->GetXaxis()->SetRange(binxmin, binxmax);
  Int_t binymin = ny*yslider->GetMinimum();
  Int_t binymax = ny*yslider->GetMaximum();
  hpxpy->GetYaxis()->SetRange(binymin, binymax);
  pad->cd();
  hpxpy->Draw("lego1");
  c1->Update();
}
```

The canvas and the sliders created in the above script are shown in the picture below.

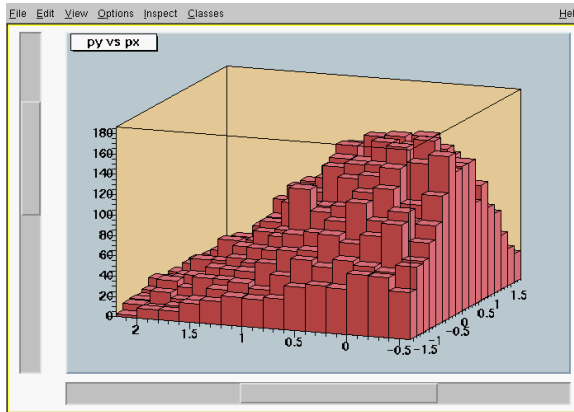

The second example uses `SetObject` (script `xyslider.C`). Same example as above but using the `SetMethod`:

```
Myclass *obj = new Myclass();
// Myclass derived from TObject
xslider->SetObject(obj);
yslider->SetObject(obj);
```

When one of the sliders will be changed, `Myclass::ExecuteEvent()` will be called with `px=0` and `py = 0`.

Axis

The axis objects are automatically built by various high level objects such as histograms or graphs. Once build, one may access them and change their characteristics. It is also possible, for some particular purposes to build axis on their own. This may be useful for example in the case one wants to draw two axis for the same plot, one on the left and one on the right.

For historical reasons, there are two classes representing axis.

TAxis * axis is the axis object, which will be returned when calling the `TH1::GetAxis()` method.

```
TAxis *axis = histo->GetXaxis();
```

Of course, you may do the same for Y and Z-axis.

The graphical representation of an axis is done with the **TGaxis** class. Instances of this class are generated by the histogram classes and **TGraph**. This is internal and the user should not have to see it.

Axis Title

The axis title is set, as with all named objects, by

```
axis->SetTitle("Whatever title you want");
```

When the axis is embedded into a histogram or a graph, one has to first extract the axis object:

```
h->GetXaxis()->SetTitle("Whatever title you want")
```

Axis Options and Characteristics

The axis options are most simply set with the styles. The available style options controlling specific axis options are the following:

```
TAxis *axis = histo->GetXaxis();
axis->SetAxisColor(Color_t color = 1);
axis->SetLabelColor(Color_t color = 1);
axis->SetLabelFont(Style_t font = 62);
axis->SetLabelOffset(Float_t offset = 0.005);
axis->SetLabelSize(Float_t size = 0.04);
axis->SetNdivisions(Int_t n = 510, Bool_t optim = kTRUE);
axis->SetNoExponent(Bool_t noExponent = kTRUE);
axis->SetTickLength(Float_t length = 0.03);
axis->SetTitleOffset(Float_t offset = 1);
axis->SetTitleSize(Float_t size = 0.02);
```

The getters corresponding to the described setters are also available. Furthermore, the general options, not specific to axis, as for instance `SetTitleTextColor()` are valid and do have an effect on axis characteristics.

Setting the Number of Divisions

Use `TAxis::SetNdivisions(ndiv, optim)` to set the number of divisions for an axis. The `ndiv` and `optim` are as follows:

- `ndiv = N1 + 100*N2 + 10000*N3`
 - `N1` = number of first divisions.
 - `N2` = number of secondary divisions.
 - `N3` = number of tertiary divisions.
- `optim = kTRUE` (default), the number of divisions will be optimized around the specified value.
- `optim = kFALSE`, or `n < 0`, the axis will be forced to use exactly `n` divisions.

For example:

- `ndiv = 0` : no tick marks.
- `ndiv = 2` : 2 divisions, one tick mark in the middle of the axis.
- `ndiv = 510` : 10 primary divisions, 5 secondary divisions
- `ndiv = -10` : exactly 10 primary divisions

Zooming the Axis

You can use `TAxis::SetRange` or `TAxis::SetRangeUser` to zoom the axis.

```
TAxis::SetRange(Int_t binfirst, Int_t binlast)
```

The `SetRange` method parameters are bin numbers. They are not axis. For example if a histogram plots the values from 0 to 500 and has 100 bins, `SetRange(0, 10)` will cover the values 0 to 50.

The parameters for `SetRangeUser` are user coordinates. If the start or end is in the middle of a bin the resulting range is approximation. It finds the low edge bin for the start and the high edge bin for the high.

```
TAxis::SetRangeUser(Axis_t ufirst, Axis_t ulast)
```

Both methods, `SetRange` and `SetRangeUser` are in the context menu of the axis and can be used interactively.

Also, you can zoom an axis interactively: click on the axis on the start, drag the cursor to the end, and release.

Drawing Axis Independently of Graphs or Histograms

An axis may be drawn independently of a histogram or a graph. This may be useful to draw for example a supplementary axis for a graph. In this case, one has to use the **TGaxis** class, the graphical representation of an axis. One may use the standard constructor for this kind of objects:

```
TGaxis(Double_t xmin,Double_t ymin,Double_t xmax,Double_t ymax,  
       Double_t wmin,Double_t wmax,Int_t ndiv = 510,Option_t* chopt,  
       Double_t gridlength = 0)
```

The arguments `xmin`, `ymin` are the coordinates of the axis' start in the user coordinates system, and `xmax`, `ymax` are the end coordinates. The arguments `wmin` and `wmax` are the minimum (at the start) and maximum (at the end) values to be represented on the axis. `ndiv` is the number of divisions (see above).

The options, given by the “chopt” string are the following:

- `chopt = 'G'`: logarithmic scale, default is linear.
- `chopt = 'B'`: Blank axis. Useful to superpose the axis.

Instead of the `wmin`, `wmax` arguments of the normal constructor, i.e. the limits of the axis, the name of a **TF1** function can be specified. This function will be used to map the user coordinates to the axis values and ticks.

The constructor is the following:

```
TGaxis(Double_t xmin,Double_t ymin,Double_t xmax,Double_t ymax,  
       const char* funcname,Int_t ndiv = 510,Option_t* chopt,  
       Double_t gridlength = 0)
```

In such a way, it is possible to obtain exponential evolution of the tick marks position, or even decreasing. In fact, anything you like.

Orientation of Tick Marks on Axis

Tick marks are normally drawn on the positive side of the axis, however, if `xmin = xmax`, then negative.

- `chopt = '+'`: tick marks are drawn on Positive side. (Default)
- `chopt = '-'`: tick marks are drawn on the negative side.
- `chopt = '+-'`: tick marks are drawn on both sides of the axis.
- `chopt = 'U'`: unlabeled axis, default is labeled.

Label Position

Labels are normally drawn on side opposite to tick marks. However,

`chopt = '='`: on Equal side.

The function **TAxis::CenterLabels()** sets the bit `kCenterLabels` and it is visible from **TAxis** context menu. It centers the bin labels and it makes sense only when the number of bins is equal to the number of tick marks. The class responsible for drawing the axis **TGaxis** inherits this property.

Label Orientation

Labels are normally drawn parallel to the axis. However, if `xmin = xmax`, then they are drawn orthogonal, and if `ymin = ymax` they are drawn parallel.

Labels for Exponents

By default, an exponent of the form 10^N is used when the label values are either all very small or very large. One can disable the exponent by calling:

```
TAxis::SetNoExponent(kTRUE)
```

Note that this option is implicitly selected if the number of digits to draw a label is less than the `fgMaxDigits` global member. If you have set the property `SetNoExponent` in **TAxis** (via `TAxis::SetNoExponent`), **TGaxis** will inherit this property. **TGaxis** is the class responsible for drawing the axis. `SetNoExponent` is also available from the axis context menu.

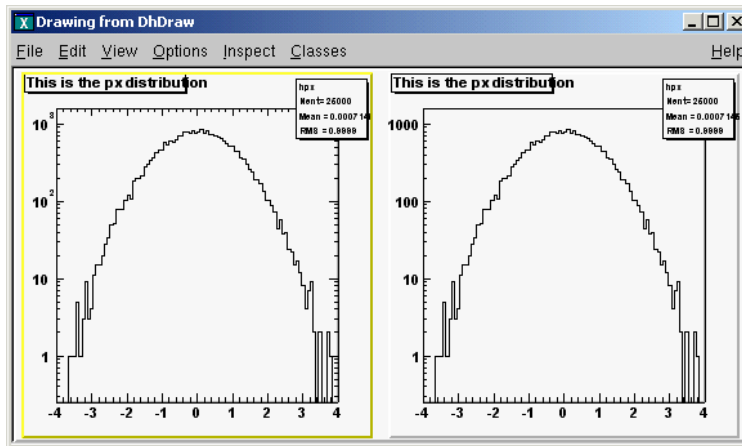

Number of Digits in Labels

TGaxis::fgMaxDigits is the maximum number of digits permitted for the axis labels above which the notation with 10^N is used. By default `fgMaxDigits` is 5, to change it use the `TGaxis::SetMaxDigits` method. For example to set `fgMaxDigits` to accept 6 digits and accept numbers like 900000 on an axis call:

```
TGaxis::SetMaxDigits(6)
```

`fgMaxDigits` must be greater than 0.

Tick Mark Label Position

Labels are centered on tick marks. However, if `xmin = xmax`, then they are right adjusted.

- `chopt = 'R'`: labels are right adjusted on tick mark (default is centered)
- `chopt = 'L'`: labels are left adjusted on tick mark.
- `chopt = 'C'`: labels are centered on tick mark.
- `chopt = 'M'`: In the Middle of the divisions.

Label Formatting

Blank characters are stripped, and then the label is correctly aligned. The dot, if last character of the string, is also stripped. In the following, we have some parameters, like tick marks length and characters height (in percentage of the length of the axis, in user coordinates). The default values are as follows:

- Primary tick marks: 3.0 %
- Secondary tick marks: 1.5 %
- Third order tick marks: .75 %
- Characters height for labels: 4%
- Labels offset: 1.0 %

Stripping Decimals

Use the `TStyle::SetStripDecimals` to strip decimals when drawing axis labels. By default, the option is set to true, and `TGaxis::PaintAxis` removes trailing zeros after the dot in the axis labels, e.g. {0, 0.5, 1, 1.5, 2, 2.5, etc.}

```
TStyle::SetStripDecimals (Bool_t strip=kTRUE)
```

If this function is called with `strip=kFALSE`, `TGaxis::PaintAxis()` will draw labels with the same number of digits after the dot, e.g. {0.0, 0.5, 1.0, 1.5, 2.0, 2.5, etc.}

Optional Grid

`chopt = 'W'`: cross-Wire

Axis Binning Optimization

By default, the axis binning is optimized.

- `chopt = 'N'`: No binning optimization
- `chopt = 'I'`: Integer labeling

Axis with Time Units

Histograms' axis can be defined as "time axis". To do that it is enough to activate the `SetTimeDisplay` attribute on a given axis. If `h` is a histogram, it is done the following way:

```
h->GetXaxis()->SetTimeDisplay(1); // X axis is a time axis
```

Two parameters can be adjusted in order to define time axis: the *time format* and the *time offset*.

Time Format

It defines the format of the labels along the time axis. It can be changed using the `TAxis` method `SetTimeFormat`. The time format is the one used by the C function `strftime()`. It is a string containing the following formatting characters:

- | | | |
|---------------|------|------------------------------|
| For the date: | • %a | abbreviated weekday name |
| | • %b | abbreviated month name |
| | • %d | day of the month (01-31) |
| | • %m | month (01-12) |
| | • %y | year without century |
| | • %Y | year with century |
| For the time: | • %H | hour (24-hour clock) |
| | • %I | hour (12-hour clock) |
| | • %p | local equivalent of AM or PM |
| | • %M | minute (00-59) |
| | • %S | seconds (00-61) |
| | • %% | % |

The other characters are output as is. For example to have a format like `dd/mm/yyyy` one should do:

```
h->GetXaxis()->SetTimeFormat ("%d\/%m\/%Y");
```

If the time format is not defined, a default one will be computed automatically.

Time Offset

This is a time in seconds in the UNIX standard UTC format (the universal time, not the local one), defining the starting date of a histogram axis. This date should be greater than 01/01/95 and is given in seconds. There are three ways to define the time offset:

1. By setting the global default time offset:

```
TDatetime da(2003,02,28,12,00,00);
gStyle->SetTimeOffset(da.Convert());
```

If no time offset is defined for a particular axis, the default time offset will be used. In the example above, notice the usage of `TDatetime` to translate an explicit date into the time in seconds required by `SetTimeFormat`.

2. By setting a time offset to a particular axis:

```
TDatetime dh(2001,09,23,15,00,00);
h->GetXaxis()->SetTimeOffset(dh.Convert());
```

3. Together with the time format using `SetTimeFormat`. The time offset can be specified using the control character `%F` after the normal time format. `%F` is followed by the date in the format: `yyyy-mm-dd hh:mm:ss`. Example:

```
h->GetXaxis()->SetTimeFormat("%d\%m\%y%F2000-02-28 13:00:01");
```

Notice that this date format is the same used by the `TDatetime` function `AsSQLString`. If needed, this function can be used to translate a time in seconds into a character string which can be appended after `%F`. If the time format is not specified (before `%F`), the automatic one will be used. The following example illustrates the various possibilities.

```
{
    gStyle->SetTitleH(0.08);
    TDatetime da(2003,02,28,12,00,00);
    gStyle->SetTimeOffset(da.Convert());
    ct = new TCanvas("ct","Time on axis",0,0,600,600);
    ct->Divide(1,3);
    ht1 = new TH1F("ht1","ht1",30000,0.,200000.);
    ht2 = new TH1F("ht2","ht2",30000,0.,200000.);
    ht3 = new TH1F("ht3","ht3",30000,0.,200000.);
    for (Int_t i=1;i<30000;i++) {
        Float_t noise = gRandom->Gaus(0,120);
        ht1->SetBinContent(i,noise);
        ht2->SetBinContent(i,noise*noise);
        ht3->SetBinContent(i,noise*noise*noise);
    }
    ct->cd(1);
    ht1->GetXaxis()->SetLabelSize(0.06);
    ht1->GetXaxis()->SetTimeDisplay(1);
    ht1->GetXaxis()->SetTimeFormat("%d\%m\%y%F2000-02-2813:00:01");
    ht1->Draw();
    ct->cd(2);
    ht2->GetXaxis()->SetLabelSize(0.06);
    ht2->GetXaxis()->SetTimeDisplay(1);
    ht2->GetXaxis()->SetTimeFormat("%d\%m\%y");
    ht2->Draw();
    ct->cd(3);
    ht3->GetXaxis()->SetLabelSize(0.06);
    TDatetime dh(2001,09,23,15,00,00);
    ht3->GetXaxis()->SetTimeDisplay(1);
    ht3->GetXaxis()->SetTimeOffset(dh.Convert());
    ht3->Draw();
}
```

The output is:

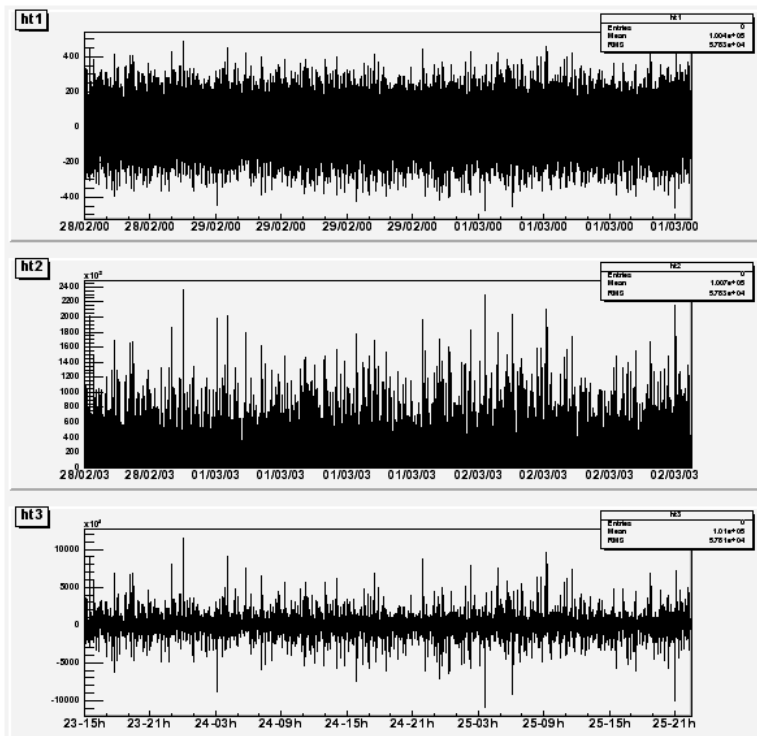

If a time axis has no specified time offset, the global time offset will be stored in the axis data structure.

The histogram limits are in seconds. If `wmin` and `wmax` are the histogram limits, the time axis will spread around the time offset value from `TimeOffset+wmin` to `TimeOffset+wmax`. Until now all examples had a lowest value equal to 0. The following example demonstrates how to define the histogram limits relatively to the time offset value.

```
{
// Define the time offset as 2003, January 1st
TDate T0(2003,01,01,00,00,00);
int X0 = T0.Convert();
gStyle->SetTimeOffset(X0);

// Define the lowest histogram limit as 2002,September 23rd
TDate T1(2002,09,23,00,00,00);
int X1 = T1.Convert()-X0;

// Define the highest histogram limit as 2003, March 7th
TDate T2(2003,03,07,00,00,00);
int X2 = T2.Convert()-X0;

TH1F * h1 = new TH1F("h1", "test", 100, X1, X2);

TRandom r;
for (Int_t i=0; i<30000; i++) {
    Double_t noise = r.Gaus(0.5*(X1+X2), 0.1*(X2-X1));
    h1->Fill(noise);
}

h1->GetXaxis()->SetTimeDisplay(1);
h1->GetXaxis()->SetLabelSize(0.03);
h1->GetXaxis()->SetTimeFormat("%Y\\/%m\\/%d");
h1->Draw();
}
```

The output is:

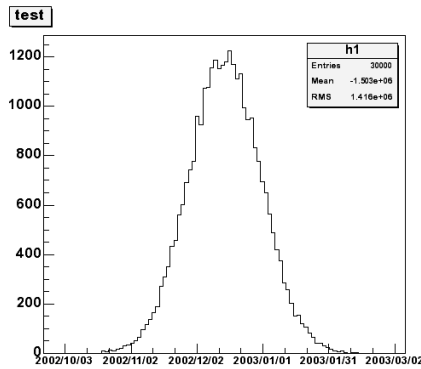

Usually time axes are created automatically via histograms, but one may also want to draw a time axis outside a "histogram context". Therefore it is useful to understand how **TGaxis** works for such axis. The time offset can be defined using one of the three methods described before. The time axis will spread around the time offset value. Actually it will go from `TimeOffset+wmin` to `TimeOffset+wmax` where `wmin` and `wmax` are the minimum and maximum values (in seconds) of the axis. Let's take again an example. Having defined "2003, February 28 at 12h" we would like to see the axis a day before and a day after.

A **TGaxis** can be created the following way (a day has 86400 seconds):

```
TGaxis *axis = new TGaxis(x1,y1,x2,y2,-100000,150000,2405,"t");
```

the "t" option (in lower case) means it is a "time axis". The axis goes from 100000 seconds before `TimeOffset` and 150000 seconds after.

So the complete macro is:

```
{
  c1 = new TCanvas("c1","Examples of TGaxis",10,10,700,500);
  c1->Range(-10,-1,10,1);

  TGaxis *axis = new TGaxis(-8,-0.6,8,-0.6,-100000,150000,2405,"t");
  axis->SetLabelSize(0.03);

  TDateTime da(2003,02,28,12,00,00);
  axis->SetTimeOffset(da.Convert());
  axis->SetTimeFormat("%d\/%m\/%Y");
  axis->Draw();
}
```

The time format is specified with:

```
axis->SetTimeFormat("%d\/%m\/%Y");
```

The macro gives the following output:

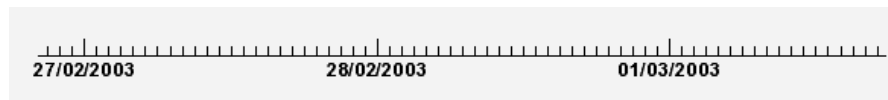

Thanks to the **TLatex** directive `#splitline` it is possible to write the time labels on two lines. In the previous example changing the `SetTimeFormat` line by:

```
axis->SetLabelOffset(0.02);
axis->SetTimeFormat("#splitline{%Y}{%d\/%m}");
```

will produce the following axis:

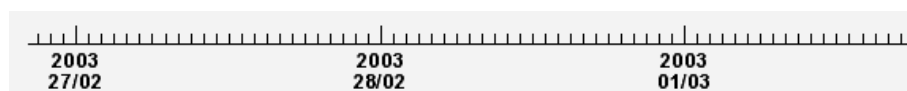

Axis: Example 1

To illustrate all what was said before, we can show two scripts. The first example creates the following picture:

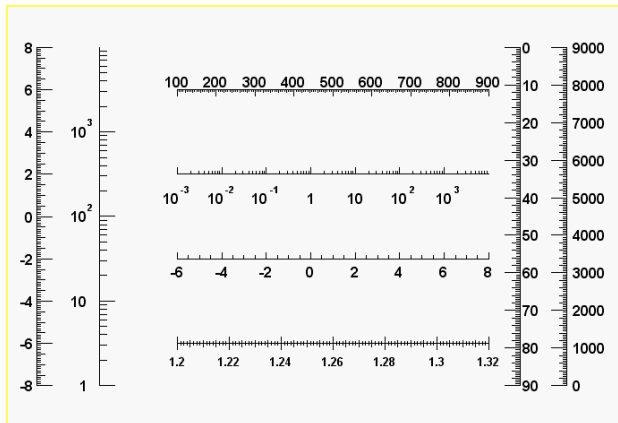

This script goes along with it:

```
{
gROOT->Reset();
c1 = new TCanvas("c1","Examples of Gaxis",10,10,700,500);
c1->Range(-10,-1,10,1);

TGaxis *axis1 = new TGaxis(-4.5,-0.2,5.5,-0.2,-6,8,510,"");
axis1->SetName("axis1");
axis1->Draw();
TGaxis *axis2 = new TGaxis(4.5,0.2,5.5,0.2,0.001,10000,510,"G");
axis2->SetName("axis2");
axis2->Draw();

TGaxis *axis3 = new TGaxis(-9,-0.8,-9,0.8,-8,8,50510,"");
axis3->SetName("axis3");
axis3->Draw();
TGaxis *axis4 = new TGaxis(-7,-0.8,7,0.8,1,10000,50510,"G");
axis4->SetName("axis4");
axis4->Draw();

TGaxis *axis5 = new TGaxis(-4.5,-6,5.5,-6,1.2,1.32,80506,"-+");
axis5->SetName("axis5");
axis5->SetLabelSize(0.03);
axis5->SetTextFont(72);
axis5->SetLabelOffset(0.025);
axis5->Draw();

TGaxis *axis6 = new TGaxis(-4.5,0.6,5.5,0.6,100,900,50510,"-");
axis6->SetName("axis6");
axis6->Draw();
TGaxis *axis7 = new TGaxis(8,-0.8,8,0.8,0,9000,50510,"+L");
axis7->SetName("axis7");
axis7->SetLabelOffset(0.01);
axis7->Draw();

// one can make axis top->bottom. However because of a problem,
// the two x values should not be equal
TGaxis *axis8 = new TGaxis(6.5,0.8,6.499,-0.8,0,90,50510,"-");
axis8->SetName("axis8");
axis8->Draw();
}
```

Axis: Example 2

The second example shows the use of the second form of the constructor, with axis ticks position determined by a function `TF1`:

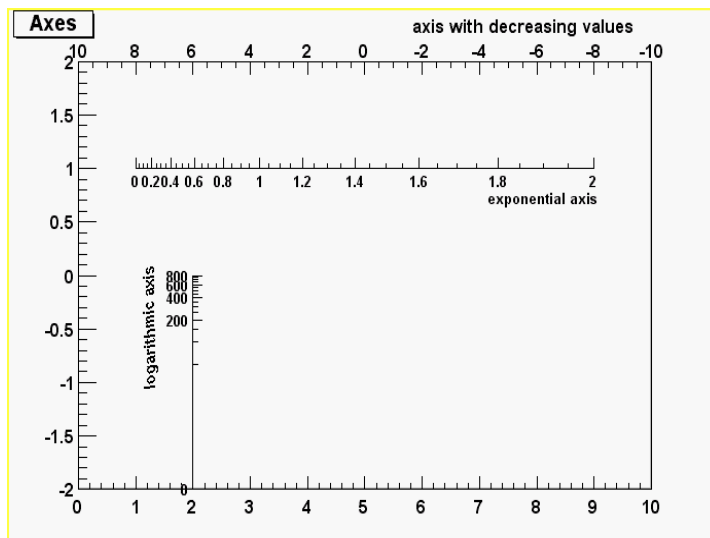

```
void gaxis3a()
{
    gStyle->SetOptStat(0);

    TH2F *h2 = new TH2F("h", "Axes", 2, 0, 10, 2, -2, 2);
    h2->Draw();

    TF1 *f1=new TF1("f1", "-x", -10, 10);
    TGaxis *A1 = new TGaxis(0, 2, 10, 2, "f1", 510, "-");
    A1->SetTitle("axis with decreasing values");
    A1->Draw();

    TF1 *f2=new TF1("f2", "exp(x)", 0, 2);
    TGaxis *A2 = new TGaxis(1, 1, 9, 1, "f2");
    A2->SetTitle("exponential axis");
    A2->SetLabelSize(0.03);
    A2->SetTitleSize(0.03);
    A2->SetTitleOffset(1.2);
    A2->Draw();

    TF1 *f3=new TF1("f3", "log10(x)", 0, 800);
    TGaxis *A3 = new TGaxis(2, -2, 2, 0, "f3", 505);
    A3->SetTitle("logarithmic axis");
    A3->SetLabelSize(0.03);
    A3->SetTitleSize(0.03);
    A3->SetTitleOffset(1.2);
    A3->Draw();
}
```

Axis: Example with Time Display

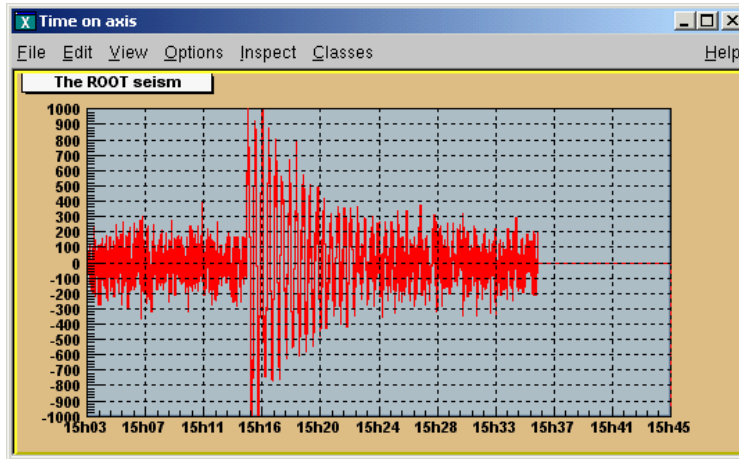

```
// strip chart example
void seism() {

    TStopwatch sw; sw.Start();
    //set time offset
    TDate_t dtime;
    gStyle->SetTimeOffset(dtime.Convert());
    TCanvas *c1 = new TCanvas("c1","Time on axis",10,10,1000,500);
    c1->SetFillColor(42);
    c1->SetFrameFillColor(33);
    c1->SetGrid();

    Float_t bintime = 1;

    //one bin = 1 second. change it to set the time scale
    TH1F *ht = new TH1F("ht","The ROOT seism",10,0,10*bintime);
    Float_t signal = 1000;
    ht->SetMaximum(signal);
    ht->SetMinimum(-signal);
    ht->SetStats(0);
    ht->SetLineColor(2);
    ht->GetXaxis()->SetTimeDisplay(1);
    ht->GetYaxis()->SetNdivisions(520);
    ht->Draw();

    for (Int_t i=1;i<2300;i++) {
        //===== Build a signal : noisy damped sine =====
        Float_t noise = gRandom->Gaus(0,120);
        if (i > 700) noise += signal*sin((i-700.)*6.28/30)
                                *exp(-(700.-i)/300.);

        ht->SetBinContent(i,noise);
        c1->Modified();
        c1->Update();
        gSystem->ProcessEvents();
        //canvas can be edited during the loop
    }

    printf("Real Time = %8.3fs,Cpu Time = %8.3fs\n",sw.RealTime()
        , sw.CpuTime());
}

```

Graphical Objects Attributes

Text Attributes

When a class contains text or derives from a text class, it needs to be able to set text attributes like font type, size, and color. To do so, the class inherits from the `TAttText` class (a secondary inheritance), which defines text attributes. `TLatex` and `TText` inherit from `TAttText`.

Setting Text Attributes Interactively

When clicking on an object containing text, one of the last items in the context menu is `SetTextAttributes`. Selecting it makes the following window appear:

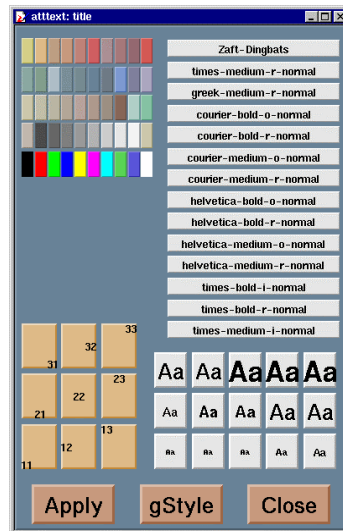

This canvas allows you to set:

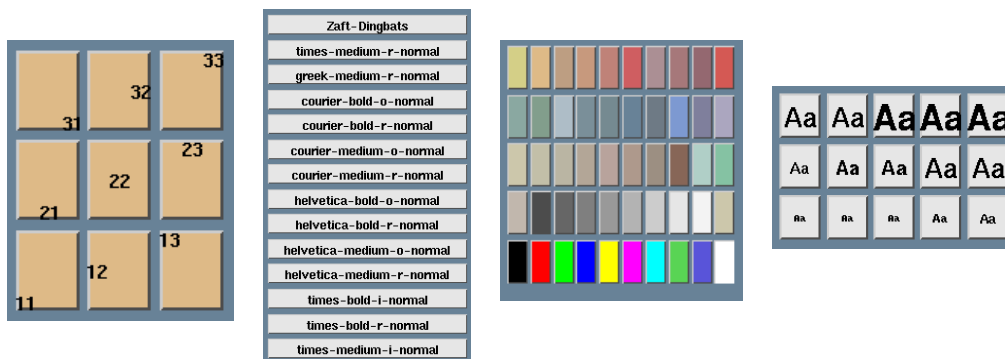

The text alignment

Font

Color

Size

Setting Text Alignment

Text alignment may also be set by a method call. What is said here applies to all objects deriving from `TAttText`, and there are many. We will take an example that may be transposed to other types. Suppose "la" is a `TLatex` object. The alignment is set with:

```
root[] la->SetTextAlign(align)
```

The parameter `align` is a short describing the alignment:
`align = 10*HorizontalAlign + VerticalAlign`

For Horizontal alignment the following convention applies:

- 1 = left
- 2 = centered
- 3 = right

For Vertical alignment the following convention applies:

- 1 = bottom
- 2 = centered
- 3 = top

For example, align: 11 = left adjusted and bottom adjusted
 32 = right adjusted and vertically centered

Setting Text Angle

Use `TAttText::SetTextAngle` to set the text angle. The `angle` is the degrees of the horizontal.

```
root[] la->SetTextAngle (angle)
```

Setting Text Color

Use `TAttText::SetTextColor` to set the text color. The `color` is the color index. The colors are described in "Color and color palettes".

```
root[] la->SetColor (color)
```

Setting Text Font

Use `TAttText::SetFont` to set the font. The parameter `font` is the font code, combining the font and precision: `font = 10 * fontID + precision`

```
root[] la->SetFont (font)
```

The table below lists the available fonts. The font IDs must be between 1 and 14. The precision can be:

- Precision = 0 fast hardware fonts (steps in the size)
- Precision = 1 scalable and rotate-able hardware fonts (see below)
- Precision = 2 scalable and rotate-able hardware fonts

When precision 0 is used, only the original non-scaled system fonts are used. The fonts have a minimum (4) and maximum (37) size in pixels. These fonts are fast and are of good quality. Their size varies with large steps and they cannot be rotated. Precision 1 and 2 fonts have a different behavior depending if True Type Fonts (TTF) are used or not. If TTF are used, you always get very good quality scalable and rotate-able fonts. However, TTF are slow. Precision 1 and 2 fonts have a different behavior for PostScript in case of `TLatex` objects:

- With precision 1, the PostScript text uses the old convention (see `TPostScript`) for some special characters to draw sub and superscripts or Greek text.
- With precision 2, the "PostScript" special characters are drawn as such. To draw sub and superscripts it is highly recommended to use `TLatex` objects instead.

For example: `font = 62` is the font with ID 6 and precision 2.

The available fonts are:

Font ID	X11	True Type name	Is italic	"boldness"
1	times-medium-i-normal	"Times New Roman"	Yes	4
2	times-bold-r-normal	"Times New Roman"	No	7
3	times-bold-i-normal	"Times New Roman"	Yes	7
4	helvetica-medium-r-normal	"Arial"	No	4
5	helvetica-medium-o-normal	"Arial"	Yes	4
6	helvetica-bold-r-normal	"Arial"	No	7
7	helvetica-bold-o-normal	"Arial"	Yes	7
8	courier-medium-r-normal	"Courier New"	No	4
9	courier-medium-o-normal	"Courier New"	Yes	4
10	courier-bold-r-normal	"Courier New"	No	7
11	courier-bold-o-normal	"Courier New"	Yes	7
12	symbol-medium-r-normal	"Symbol"	No	6
13	times-medium-r-normal	"Times New Roman"	No	4
14		"Wingdings"	No	4

Here is an example of what the fonts look like:

ID 1: *The quick brown fox is not here anymore*
 ID 2: **The quick brown fox is not here anymore**
 ID 3: ***The quick brown fox is not here anymore***
 ID 4: The quick brown fox is not here anymore
 ID 5: *The quick brown fox is not here anymore*
 ID 6: **The quick brown fox is not here anymore**
 ID 7: ***The quick brown fox is not here anymore***
 ID 8: The quick brown fox is not here anymore
 ID 9: *The quick brown fox is not here anymore*
 ID 10: **The quick brown fox is not here anymore**
 ID 11: ***The quick brown fox is not here anymore***
 ID 12: Τηρ θυιχκ βρωων φοξ ισ νοτ ηερε ανψμορε
 ID 13: The quick brown fox is not here anymore
 ID 14: **The quick brown fox is not here anymore**

This script makes the image of the different fonts:

```

{
  textc = new TCanvas("textc", "Example of text", 1);
  for (int i=1; i<15; i++) {
    cid = new char[8];
    sprintf(cid, "ID %d :", i);
    cid[7] = 0;

    lid = new TLatex(0.1, 1-(double)i/15, cid);
    lid->SetTextFont(62);
    lid->Draw();
    l = new TLatex(.2, 1-(double)i/15, "The quick brown fox is not here anymore");

    l->SetTextFont(i*10+2);
    l->Draw();
  }
}

```

How to use True Type Fonts

You can activate the True Type Fonts by adding the following line in your `.rootrc` file.

```
Unix.*.Root.UseTTFonts: true
```

You can check that you indeed use the `TTF` in your Root session. When the `TTF` is active, you get the following message at the start of a session:

```
"Free Type Engine v1.x used to render TrueType fonts."
```

You can also check with the command:

```
gEnv->Print()
```

Setting Text Size

Use `TAttText::SetTextSize` to set the text size.

```
root[] la->SetTextSize(size)
```

The `size` is the text size expressed in percentage of the current pad size.

The text size in pixels will be:

- If current pad is horizontal, the size in pixels = `textsize * canvas_height`
- If current pad is vertical, the size in pixels = `textsize * canvas_width`

Line Attributes

All classes manipulating lines have to deal with line attributes. This is done by using secondary inheritance of the class `TAttLine`.

Setting Line Attributes Interactively

When clicking on an object being a line or having some line attributes, one of the last items in the context menu is `SetLineAttributes`. Selecting it makes the following window appear:



This canvas allows you to set:

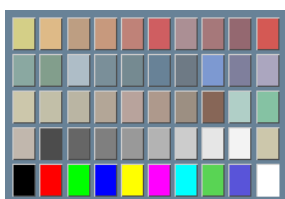

The line color

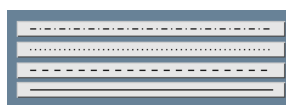

Style



Width

Setting Line Color

Line color may be set by a method call. What is said here applies to all objects deriving from **TAttLine**, and there are many (histograms, plots). We will take an example that may be transposed to other types. Suppose "li" is a **TLine** object. The line color is set with:

```
root[] li->SetLineColor(color)
```

The argument `color` is a color number. The colors are described in "Color and Color Palettes"

Setting Line Style

Line style may be set by a method call. What is said here applies to all objects deriving from **TAttLine**, and there are many (histograms, plots). We will take an example that may be transposed to other types. Suppose "li" is a **TLine** object. The line style is set with:

```
root[] li->SetLineStyle(style)
```

The argument `style` is one of: 1=solid, 2=dash, 3=dash-dot, 4=dot-dot.

Setting Line Width

Line width may be set by a method call. What is said here applies to all objects deriving from **TAttLine**, and there are many (histograms, plots). We will take an example that may be transposed to other types. Suppose "li" is a **TLine** object. The line width is set with:

```
root[] li->SetLineWidth(width)
```

The `width` is the width expressed in pixel units.

Fill Attributes

Almost all graphics classes have a fill area somewhere. These classes have to deal with fill attributes. This is done by using secondary inheritance of the class **TAttFill**.

Setting Fill Attributes interactively

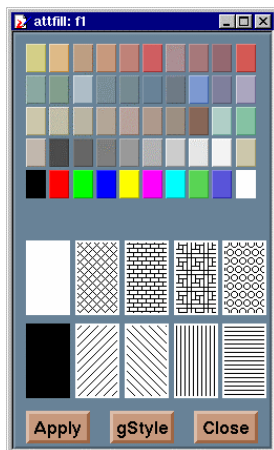

When clicking on an object having a fill area, one of the last items in the context menu is `SetFillAttributes`. Selecting it makes the following window appear:

This canvas allows you to set:

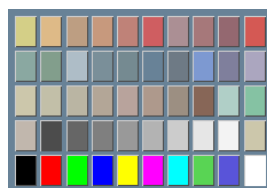

The fill color

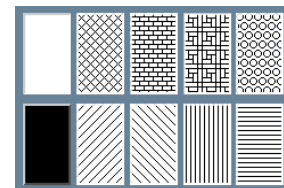

The Style

gFillColor

Fill color may be set by a method call. What is said here applies to all objects deriving from **TAttFill**, and there are many (histograms, plots). We will take an example that may be transposed to other types. Suppose "h" is a **TH1F** (1 dim histogram) object. The histogram fill color is set with:

```
root[] h->SetFillColor(color)
```

The `color` is a color number. The colors are described in "Color and color palettes"

Setting Fill Style

Fill style may be set by a method call. What is said here applies to all objects deriving from **TAttFill**, and there are many (histograms, plots). We will take an example that may be transposed to other types. Suppose "h" is a **TH1F** (1 dim histogram) object. The histogram fill style is set with:

```
root[] h->SetFillStyle(style)
```

The convention for style is:

```

0:    hollow          4000 to 4100: transparency
1001: solid          4000 = fully transparent
2001: hatch style    4100 = fully opaque
3000 + pattern number: patterns

```

The various patterns are represented here:

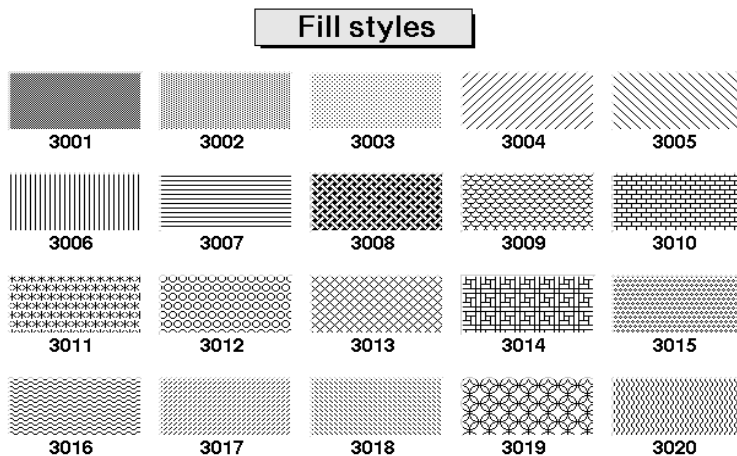

Color and Color Palettes

At initialization time, a table of basic colors is generated when the first Canvas constructor is called. This table is a linked list, which can be accessed from the **gROOT** object (see **TROOT::GetListOfColors()**). Each color has an index and when a basic color is defined, two "companion" colors are defined:

- The dark version (`color_index + 100`)
- The bright version (`color_index + 150`)

The dark and bright colors are used to give 3-D effects when drawing various boxes (see **TWbox**, **TPave**, **TPaveText**, **TPaveLabel**, etc). If you have a black and white copy of the manual, here are the basic colors and their indices:

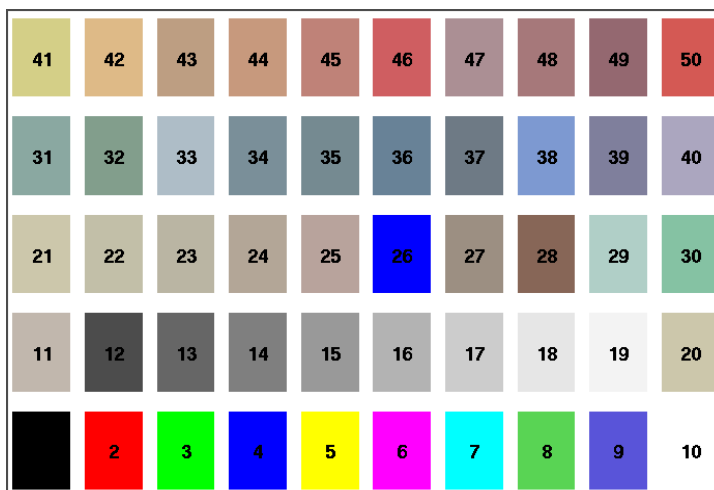

- 1 = black
- 2 = red
- 3 = bright green
- 4 = bright blue
- 5 = yellow
- 6 = hot pink
- 7 = aqua
- 8 = green
- 9 = blue
- 0 -> 9: basic colors
- 10 -> 19: shades of gray
- 20 -> 29: shades of brown
- 30 -> 39: shades of blue
- 40 -> 49: shades of red

The list of currently supported basic colors (here dark and bright colors are not shown) are shown. The color numbers specified in the basic palette, and the picture above, can be viewed by selecting the item "Colors" in the "View" menu of the canvas toolbar. Other colors may be defined by the user. To do this, one has to build a new `TColor` object:

```
TColor(Int_t color,Float_t r,Float_t g,Float_t b,const char* name)
```

One has to give the color number and the three Red, Green, Blue values, each being defined from 0 (min) to 1(max). An optional name may be given. When built, this color is automatically added to the existing list of colors. If the color number already exists, one has to extract it from the list and redefine the RGB values. This may be done for example with:

```
root[] color=(TColor*)(gROOT->GetListOfColors()->At(index_color))
root[] color->SetRGB(r,g,b)
```

Where `r`, `g` and `b` go from 0 to 1 and `index_color` is the color number you wish to change.

Color Palette (for Histograms)

Defining one color at a time may be tedious. The color palette is used by the histogram classes (see Draw Options). For example, `TH1::Draw("col")` draws a 2-D histogram with cells represented by a box filled with a color `CI` function of the cell content. If the cell content is `N`, the color `CI` used will be the color number in `colors[N]`. If the maximum cell content is `> ncolors`, all cell contents are scaled to `ncolors`. The current color palette does not have a class or global object of its own. It is defined in the current style as an array of color numbers. One may change the current palette with the method `TStyle::SetPalette(Int_t ncolors, Int_t* color_indexes)`.

By default, or if `ncolors <= 0`, a default palette (see above) of 50 colors is defined. The colors defined in this palette are good for coloring pads, labels, and other graphic objects. If `ncolors > 0` and `colors = 0`, the default palette is used with a maximum of `ncolors`. If `ncolors == 1` && `colors == 0`, then a pretty palette with a spectrum Violet->Red is created. It is recommended to use this pretty palette when drawing lego(s), surfaces or contours. For example, to set the current palette to the "pretty" one do:

```
root[] gStyle->SetPalette(1)
```

A more complete example is shown below. It illustrates the definition of a custom palette. You can adapt it to suit your needs. In case you use it for contour coloring, with the current color/contour algorithm, always define two more colors than the number of contours.

```
void palette() { // Example of creating new colors (purples)
  const Int_t colNum = 10; // and defining of a new palette
  Int_t palette[colNum];
  for (Int_t i=0; i<colNum; i++) {
    // get the color and if it does not exist create it
    if (!gROOT->GetColor(230+i) ){
      TColor *color = new TColor(230+i,1-(i/((colNum)*1.0)),0.3,0.5,"");
    } else {
      TColor *color = gROOT->GetColor(230+i);
      color->SetRGB(1-(i/((colNum)*1.0)),0.3,0.5);
    }
    palette[i] = 230+i;
  }
  gStyle->SetPalette(colNum,palette);
  TF2 *f2 = new TF2("f2","exp(-(x^2)-(y^2))",-3,3,-3,3);

  // two contours less than the number of colors in palette
  f2->SetContour(colNum-2);
  f2->Draw("cont");
}
```

The Graphical Editor



ROOT has a built-in graphics editor to draw and edit graphic primitives starting from an empty canvas or on top of a picture (e.g. histogram). The editor is started by selecting the "Editor" item in the canvas "Edit" menu. A menu appears into an independent window. You can create the following graphical objects:

An arc or circle: Click on the center of the arc, and then move the mouse. A rubber band circle is shown. Click again with the left button to freeze the arc.

A line or an arrow: Click with the left button at the point where you want to start the arrow, then move the mouse and click again with the left button to freeze the arrow.

A Diamond: Click with the left button and freeze again with the left button. The editor draws a rubber band box to suggest the outline of the diamond.

An Ellipse: Proceed like for an arc. You can grow/shrink the ellipse by pointing to the sensitive points. They are highlighted. You can move the ellipse by clicking on the ellipse, but not on the sensitive points. If, with the ellipse context menu, you have selected a fill area color, you can move a filled-ellipse by pointing inside the ellipse and dragging it to its new position. Using the context menu, you can build an arc of ellipse and tilt the ellipse.

A Pad: Click with the left button and freeze again with the left button. The editor draws a rubber band box to suggest the outline of the pad.

A Pave Label: Proceed like for a pad. Type the text to be put in the box. Then type a carriage return. The text will appear in the box.

A Pave Text or Paves Text: Proceed like for a pad. You can then click on the `TPaveText` object with the right mouse button and select the option `AddText`.

A Poly Line: Click with the left button for the first point, move the mouse, click again with the left button for a new point. Close the poly-line with a double click. To edit one vertex point, pick it with the left button and drag to the new point position.

A CurlyLine: Proceed as for the arrow/line. Once done, click with the third button to change the characteristics of the curly line, like transform it to wave, change the wavelength, etc...

A CurlyArc: Proceed like for the arrow/line. The first click is located at the position of the center, the second click at the position of the arc beginning. Once done, one obtains a curly ellipse, for which one can click with the third button to change the characteristics, like transform it to wavy, change the wavelength, set the minimum and maximum angle to make an arc that is not closed, etc...

A Text /Latex string: Click with the left button where you want to draw the text and then type in the text terminated by carriage return. All `TLatex` expressions are valid. To move the text or formula, point on it keeping the left mouse button pressed and drag the text to its new position. You can grow/shrink the text if you position the mouse to the first top-third part of the string, then move the mouse up or down to grow or shrink the text respectively. If you position the mouse near the bottom-end of the text, you can rotate it.

A Marker: Click with the left button where to place the marker. The marker can be modified by `gStyle->SetMarkerStyle()`.

A Graphical Cut: Click with the left button on each point of a polygon delimiting the selected area. Close the cut by double clicking on the last point. A `TCutG` object is created. It can be used as a selection for a `TTree::Draw`.

You can get a pointer to this object with:

```
TCutG cut = (TCutG*)gPad->GetPrimitive("CUTG")
```

Once you are happy with your picture, you can select the `Save as canvas.C` item in the `canvas File` menu. This will automatically generate a script with the C++ statements corresponding to the picture. This facility also works if you have other objects not drawn with the graphics editor (histograms for example).

Copy/Paste with DrawClone

You can make a copy of a canvas using `TCanvas::DrawClonePad`. This method is unique to `TCanvas`. It clones the entire canvas to the active pad. There is a more general method `TObject::DrawClone`, which all objects descendents of `TObject`, specifically all graphic objects inherit. Below are two examples, one to show the use of `DrawClonePad` and the other to show the use of `DrawClone`.

Example 1: TCanvas::DrawClonePad

In this example we will copy an entire canvas to a new one with `DrawClonePad`. Run the script `draw2dopt.C`.

```
root[] .x tutorials/draw2dopt.C
```

This creates a canvas with 2D histograms. To make a copy of the canvas follow these steps:

- Right-click on it to bring up the context menu
- Select `DrawClonePad`

This copies the entire canvas and all its sub-pads to a new canvas. The copied canvas is a deep clone, and all the objects on it are copies and independent of the original objects. For instance, change the fill on one of the original histograms, and the cloned histogram retains its attributes. `DrawClonePad` will copy the canvas to the active pad; the target does not have to be a canvas. It can also be a pad on a canvas.

Example 2: TObject::DrawClone

If you want to copy and paste a graphic object from one canvas or pad to another canvas or pad, you can do so with `DrawClone` method inherited from `TObject`. The `TObject::DrawClone` method is inherited by all graphics objects. In this example, we create a new canvas with one histogram from each of the canvases from the script `draw2dopt.C`.

1. Start a new ROOT session and execute the script `draw2dopt.C`
2. Select a canvas displayed by the script, and create a new canvas from the File menu (`c1`).
3. Make sure that the target canvas (`c1`) is the active one by middle clicking on it. If you do this step right after step 2, `c1` will be active.
4. Select the pad with the first histogram you want to copy and paste.
5. Right click on it to show the context menu, and select `DrawClone`.
6. Leave the option blank and hit OK.

Repeat these steps for one histogram on each of the canvases created by the script, until you have one pad from each type. If you wanted to put the same annotation on each of the sub pads in the new canvas, you could use `DrawClone` to do so. Here we added the date to each pad. The steps to this are:

1. Create the label in on of the pads with the graphics editor.
2. Middle-click on the target pad to make it the active pad
3. Use `DrawClone` method of the label to draw it in each of the other panels.

The option in the `DrawClone` method argument is the `Draw` option for a histogram or graph. A call to `TH1::DrawClone` can clone the histogram with a different draw option.

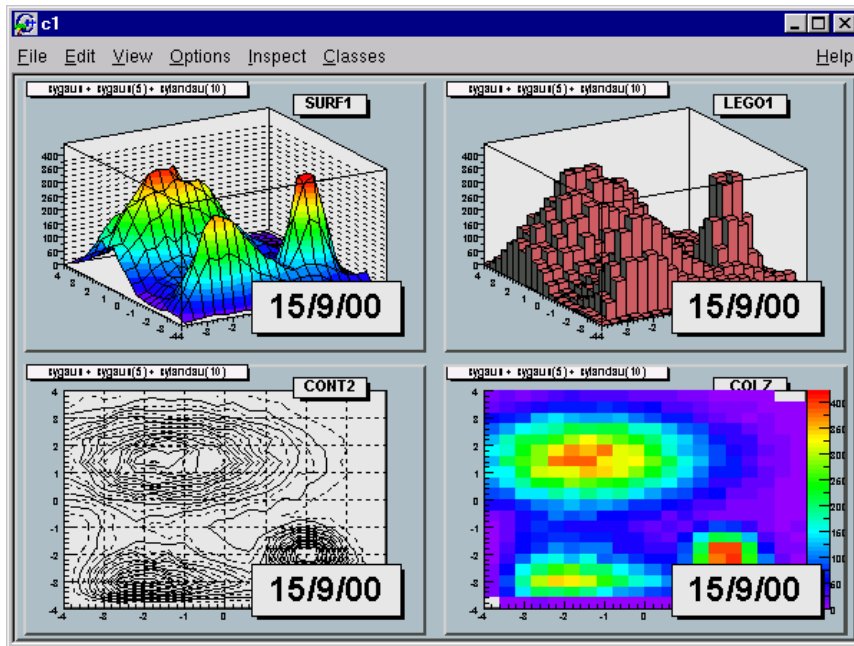

Copy/Paste Programmatically

To copy and paste the four pads from the command line or in a script you would execute the following statements:

```
root[] .x tutorials/draw2dopt.C
root[] TCanvas c1("c1","Copy Paste",200,200,800,600);
root[] surfaces->cd(1); // get the first pad
root[] TPad *p1 = gPad;
root[] lego->cd(2); // get the next pad
root[] TPad *p2 = gPad;
root[] cont->cd(3); // get the next pad
root[] TPad *p3 = gPad;
root[] c2h->cd(4); // get the next pad
root[] TPad *p4 = gPad;
root[] // draw the four clones
root[] c1->cd();
root[] p1->DrawClone();
root[] p2->DrawClone();
root[] p3->DrawClone();
root[] p4->DrawClone();
```

Note that the pad is copied to the new canvas in the same location as in the old canvas. For example if you were to copy the third pad of `surf` to the top left corner of the target canvas you would have to reset the coordinates of the cloned pad.

Legends

Legends for a graph are obtained with a `TLegend` object. This object points to markers, lines, boxes, histograms, graphs and represent their marker, line, fill attributes. Any object that has a marker or line or fill attribute may have an associated legend. A `TLegend` is a panel with several entries (class `TLegendEntry`) and is created by the constructor

```
TLegend( Double_t x1,Double_t y1,Double_t x2,Double_t y2,
         const char *header, Option_t *option)
```

The legend is defined with default coordinates, border size and option. x_1, y_1, x_2, y_2 are the coordinates of the legend in the current pad (in NDC coordinates by default). The default text attributes for the legend are:

- Alignment = 12 left adjusted and vertically centered
- Angle = 0 (degrees)
- Color = 1 (black)
- Size = calculate when number of entries is known
- Font = helvetica-medium-r-normal scalable font = 42, and bold = 62 for title

The title is a regular entry and supports **T \LaTeX** . The default is no title (`header = 0`). The options are the same as for **TPave**; by default, they are "brNDC". Once the legend box is created, one has to add the text with the `AddEntry()` method:

```
TLegendEntry* TLegend::AddEntry(TObject *obj, const char *label, Option_t *option)
```

The parameters are:

- `*obj`: is a pointer to an object having marker, line, or fill attributes (for example a histogram, or graph)
- `label`: is the label to be associated to the object
- `option`:
 - "L" draw line associated with line attributes of `obj` if `obj` has them (inherits from **TAttLine**)
 - "P" draw poly-marker associated with marker attributes of `obj` if `obj` has them (inherits from **TAttMarker**)
 - "F" draw a box with fill associated with fill attributes of `obj` if `obj` has them (inherits **TAttFill**)

One may also use the other form of `AddEntry`:

```
TLegendEntry* TLegend::AddEntry(const char *name,
                                const char *label, Option_t *option)
```

where `name` is the name of the object in the pad. Other parameters are as in the previous case. Here's an example of a legend created with **TLegend**

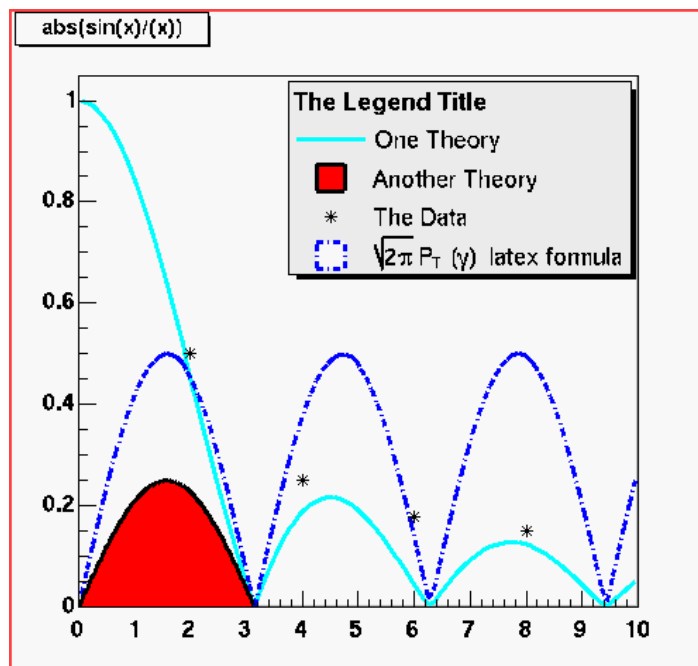

The legend part of this plot was created as follows:

```

leg = new TLegend(0.4,0.6,0.89,0.89);
leg->AddEntry(fun1,"One Theory","l");
leg->AddEntry(fun3,"Another Theory","f");
leg->AddEntry(gr,"The Data","p");
leg->Draw();

// oops we forgot the blue line... add it after
leg->AddEntry(fun2,"#sqrt{2#pi} P_{T} (#gamma) latex formula","f");

// and add a header (or "title") for the legend
leg->SetHeader("The Legend Title");
leg->Draw();

```

where `fun1`, `fun2`, `fun3` and `gr` are pre-existing functions and graphs. You can edit the **TLegend** by right clicking on it.

The PostScript Interface

To generate a PostScript (or encapsulated PostScript) file for a single image in a canvas, you can:

Select the "Print PostScript" item in the canvas "File" menu. By default, a PostScript file called `canvas.ps` is generated.

Click in the canvas area, near the edges, with the right mouse button and select the "Print" item. You can select the name of the PostScript file. If the file name is `xxx.ps`, you will generate a PostScript file named `xxx.ps`. If the file name is `xxx.eps`, you generate an encapsulated Postscript file instead. In your program (or script), you can type:

```
c1->Print("xxx.ps")
```

Or

```
c1->Print("xxx.eps")
```

This will generate a file of canvas pointed to by `c1`.

```
pad1->Print("xxx.ps")
```

This prints the picture in the pad pointed by `pad1`.

The **TPad::Print** method has a second parameter called `option`. Its value can be:

- 0 which is the default and is the same as "ps"
- "ps" a Postscript file is produced
- "eps" an Encapsulated Postscript file is produced
- "gif" a GIF file is produced
- "cxx" a C++ macro file is produced

You do not need to specify the second parameter; you can indicate by the filename extension what format you want to save a canvas in (i.e. `canvas.ps`, `canvas.gif`, `canvas.C`, etc).

The size of the PostScript picture, by default, is computed to keep the aspect ratio of the picture on the screen, where the size along `x` is always 20 cm. You can set the size of the PostScript picture before generating the picture with a command such as:

```

TPostScript myps("myfile.ps",111)
myps.Range(xsize,ysize);
object->Draw();
myps.Close();

```

The first parameter in the `TPostScript` constructor is the name of the file. The second parameter is the format option:

```
111 -ps portrait
112 -ps landscape
113 -eps
```

You can set the default paper size with:

```
gStyle->SetPaperSize(xsize,ysize);
```

You can resume writing again in this file with `mysps.Open()`. Note that you may have several Post Script files opened simultaneously. Use `TPostScript::Text(x,y,"string")` to add text to a postscript file. This method writes the string in quotes into a PostScript file at position `x`, `y` in world coordinates.

Special Characters

The following characters have a special action on the PostScript file:

```
` : Go to Greek
' : Go to special
~ : Go to Zapf Dingbats
? : Go to subscript
^ : Go to superscript
! : go to normal level of script
& : Backspace one character
# : End of Greek or of Zapf Dingbats
```

These special characters are printed as such on the screen. To generate one of these characters on the PostScript file, you must escape it with the escape character `"@"`. The use of these special characters is illustrated in several scripts referenced by the `TPostScript` constructor.

Multiple Pictures in a PostScript File: Case 1

The following script is an example illustrating how to open a PostScript file and draw several pictures. The generation of a new PostScript page is automatic when `TCanvas::Clear` is called by `object->Draw()`.

```
{
TFile f("hsimple.root");
TCanvas c1("c1","canvas",800,600);

//select PostScript output type
Int_t type = 111; //portrait ps
// Int_t type = 112; //landscape ps
// Int_t type = 113; //eps

//create a PostScript file and set the paper size
TPostScript ps("test.ps",type);
ps.Range(16,24); //set x,y of printed page

//draw 3 histograms from file hsimple.root on separate pages
hpx->Draw();
c1.Update(); //force drawing in a script
hprof->Draw();
c1.Update();
hpx->Draw("lego1");
c1.Update();
ps.Close();
}
```

Multiple Pictures in a PostScript File: Case 2

This example shows 2 pages. The canvas is divided. `TPostScript::NewPage` must be called before starting a new picture. `object->Draw` does not clear the canvas in this case because we clear only the pads and not the main canvas. Note that `c1->Update` must be called at the end of the first picture.

```
{
  TFile *f1 = new TFile("hsimple.root");
  TCanvas *c1 = new TCanvas("c1");
  TPostScript *ps = new TPostScript("file.ps",112);
  c1->Divide(2,1);      // picture 1
  ps->NewPage();
  c1->cd(1);
  hpx->Draw();
  c1->cd(2);
  hprof->Draw();
  c1->Update();        // picture 2
  ps->NewPage();
  c1->cd(1);
  hpncpy->Draw();
  c1->cd(2);
  ntuple->Draw("px");
  c1->Update();
  ps->Close();        // invoke PostScript viewer
  gSystem->Exec("gs file.ps");
}
```

Create or Modify a Style

All objects that can be drawn in a pad inherit from one or more attribute classes like `TAttLine`, `TAttFill`, `TAttText`, `TAttMarker`. When the objects are created, their default attributes are taken from the current style. The current style is an object of the class `TStyle` and can be referenced via the global variable `gStyle` (in `TStyle.h`). See the class `TStyle` for a complete list of the attributes that can be set in one style. ROOT provides several styles called:

- "Default" The default style
- "Plain" The simple style (black and white)
- "Bold" Bolder lines
- "Video" Suitable for html output or screen viewing

The "Default" style is created by:

```
TStyle *default = new TStyle("Default","Default Style");
```

The "Plain" style can be used if you are working on a monochrome display or if you want to get a "conventional" PostScript output. As an example, these are the instructions in the ROOT constructor to create the "Plain" style.

```
TStyle *plain = new TStyle("Plain","Plain Style(no colors/fill areas)");
plain->SetCanvasBorderMode(0);
plain->SetPadBorderMode(0);
plain->SetPadColor(0);
plain->SetCanvasColor(0);
plain->SetTitleColor(0);
plain->SetStatColor(0);
```

You can set the current style with:

```
gROOT->SetStyle(style_name);
```

You can get a pointer to an existing style with:

```
TStyle *style = gROOT->GetStyle(style_name);
```

You can create additional styles with:

```
TStyle *st1 = new TStyle("st1", "my style");
st1->Set...
st1->cd(); // this becomes now the current style gStyle
```

In your `rootlogon.C` file, you can redefine the default parameters via statements like:

```
gStyle->SetStatX(0.7);
gStyle->SetStatW(0.2);
gStyle->SetLabelOffset(1.2);
gStyle->SetLabelFont(72);
```

Note that when an object is created, its attributes are taken from the current style. For example, you may have created a histogram in a previous session and saved it in a file. Meanwhile, if you have changed the style, the histogram will be drawn with the old attributes. You can force the current style attributes to be set when you read an object from a file by calling `ForceStyle` before reading the objects from the file.

```
gROOT->ForceStyle();
```

When you call `gROOT->ForceStyle()` and read an object from a ROOT file, the objects method `UseCurrentStyle` is called. The attributes saved with the object are replaced by the current style attributes. You can also call `myObject->UseCurrentStyle()` directly. For example if you have a canvas or pad with your histogram or any other object, you can force these objects to get the attributes of the current style with:

```
canvas->UseCurrentStyle();
```

The description of the style functions should be clear from the name of the `TStyle` setters or getters. Some functions have an extended description, in particular:

- **TStyle::SetLabelFont**
- **TStyle::SetLineStyleString**: set the format of dashed lines.
- **TStyle::SetOptStat**
- **TStyle::SetPalette** to change the colors palette
- **TStyle::SetTitleOffset**
- **TStyle::SetOptDate(Int_t optdate)** to support several date formats. If `optdate` is non null, the current date/time will be printed in the canvas. The position of the date string can be controlled by:
 - `optdate = 10*format + mode`
 - `mode = 1` the date is printed in the bottom/left corner
 - `mode = 2` date is printed in the bottom/right corner
 - `mode = 3` date is printed in the top/right corner
 - `format = 0` (default) date has the format like:
"Wed Sep 25 17:10:35 2002"
 - `format = 1` date has the format like: "2002-09-25"
 - `format = 2` date has the format like: "2002-09-25 17:10:35"

10 Folders and Tasks

Folders

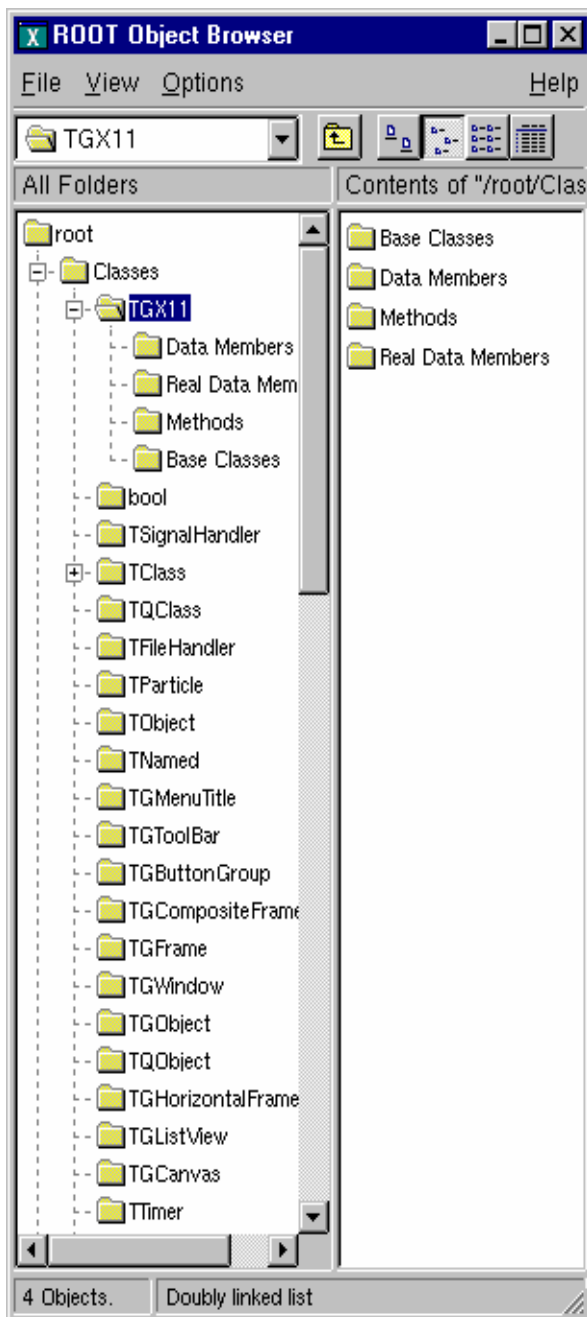

A **TFolder** is a collection of objects visible and expandable in the ROOT object browser. Folders have a name and a title and are identified in the folder hierarchy by an "UNIX-like" naming convention. The base of all folders is `//root`. It is visible at the top of the left panel in the browser. The browser shows several folders under `//root`.

New folders can be added and removed to/from a folder.

Why Use Folders?

One reason to use folders is to reduce class dependencies and improve modularity. Each set of data has a producer class and one or many consumer classes. When using folders, the producer class places a pointer to the data into a folder, and the consumer class retrieves a reference to the folder.

The consumer can access the objects in a folder by specifying the path name of the folder.

Here is an example of a folder's path name:

```
//root/Event/Hits/TCP
```

One does not have to specify the full path name. If the partial path name is unique, it will find it; otherwise it will return the first occurrence of the path.

The first diagram shows a system without folders. The objects have pointers to each other to access each other's data. Pointers are an efficient way to share data between classes. However, a direct pointer creates a direct coupling between classes. This design can become a very tangled web of dependencies in a system with a large number of classes.

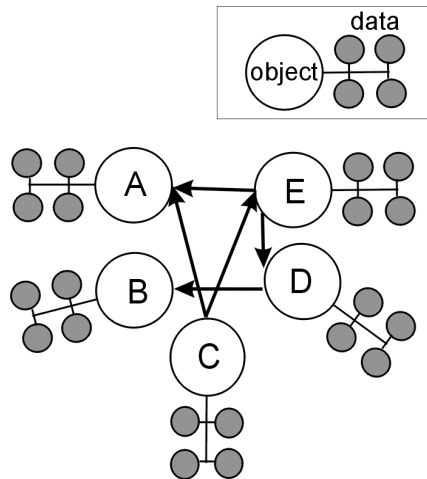

In the second diagram a reference to the data is in the folder and the consumers refer to the folder rather than each other to access the data. The naming and search service provided by the ROOT folders hierarchy provides an alternative. It loosely couples the classes and greatly enhances I/O operations. In this way, folders separate the data from the algorithms and greatly improve the modularity of an application by minimizing the class dependencies.

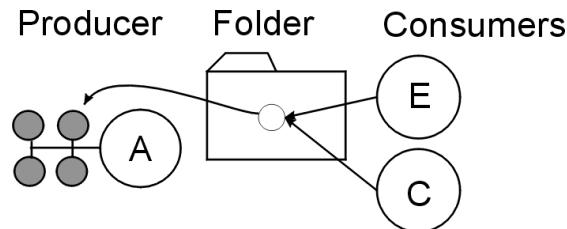

In addition, the folder hierarchy creates a picture of the data organization. This is useful when discussing data design issues or when learning the data organization. The example below illustrates this point.

How to Use Folders

Using folders means to build a hierarchy of folders, posting the reference to the data in the folder by the producer, and creating a reference to the folder by the user.

Creating a Folder Hierarchy

To create a folder hierarchy you add the top folder of your hierarchy to `//root`. Then you add a folder to an existing folder with the `TFolder::AddFolder` method. This method takes two parameters: the name and title of the folder to be added. It returns a pointer of the newly created folder.

The code below creates the folder hierarchy shown in the browser.

```
{
// Add the top folder of my hierarchy to //root
TFolder *alroot = gROOT->GetRootFolder()->AddFolder
    ("alroot","alroot top level folders");

// Add the hierarchy to the list of browsables
gROOT->GetListOfBrowsables()->Add(alroot,"alroot");

// Create and add the constants folder
TFolder *constants = alroot->AddFolder
    ("Constants","Detector constants");
// Create and add the pdg folder to pdg
TFolder *pdg = constants->AddFolder("DatabasePDG","PDG database");
// Create and add the run folder
TFolder *run = alroot->AddFolder("Run","Run dependent folders");
// Create and add the configuration folder to run
TFolder *configuration = run->AddFolder("Configuration",
    "Run configuration");

// Create and add the run_mc folder
TFolder *run_mc = alroot->AddFolder("RunMC",
    "MonteCarlo run dependent folders");

// Create and add the configuration_mc folder to run_mc
TFolder *configuration_mc = run_mc->AddFolder("Configuration",
    "MonteCarlo run configuration");
}
```

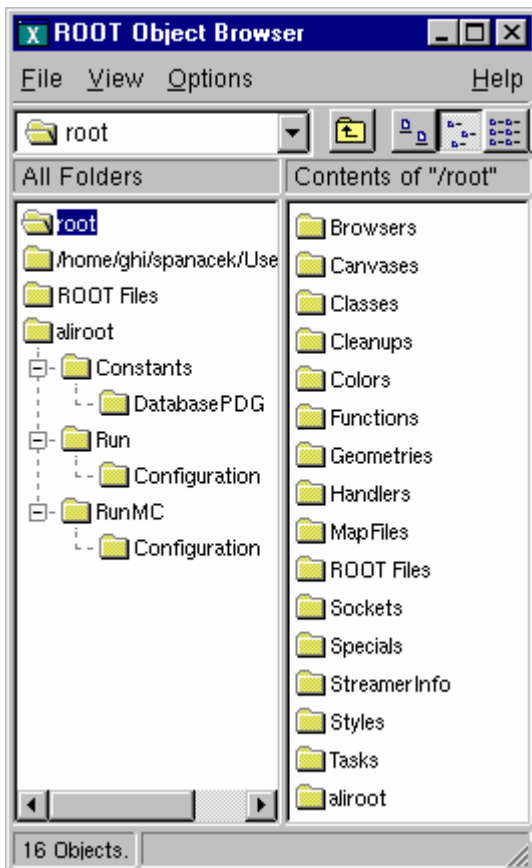

In this macro, the folder is also added to the list of browseable. This way, it is visible in the browser on the top level.

Posting Data to a Folder (Producer)

A **TFolder** can contain other folders as shown above or any **TObject** descendents. In general, users will not post a single object to a folder, they will store a collection or multiple collections in a folder. For example, to add an array to a folder:

```
TObjArray *array;
run_mc->Add(array);
```

Reading Data from a Folder (Consumer)

One can search for a folder or an object in a folder using the **TROOT::FindObjectAny** method.

FindObjectAny analyzes the string passed as its argument and searches in the hierarchy until it finds an object or folder matching the name.

With `FindObjectAny`, you can give the full path name, or the name of the folder. If only the name of the folder is given, it will return the first instance of that name.

```
conf = (TFolder*)gROOT->FindObjectAny("/aliroot/Run/Configuration");
// or
conf = (TFolder*)gROOT->FindObjectAny("Configuration");
```

A string-based search is time consuming. If the retrieved object is used frequently or inside a loop, you should save a pointer to the object as a class data member. Use the naming service only in the initialization of the consumer class. When a folder is deleted, any reference to it in the parent or other folder is deleted also.

By default, a folder does not own the object it contains. You can overwrite that with `TFolder::SetOwner`. Once the folder is the owner of its contents, the contents are deleted when the folder is deleted. Some ROOT objects are automatically added to the folder hierarchy. For example, the following folders exist on start up:

<code>//root/ROOT Files</code>	with the list of open Root files
<code>//root/Classes</code>	with the list of active classes
<code>//root/Geometries</code>	with active geometries
<code>//root/Canvases</code>	with the list of active canvases
<code>//root/Styles</code>	with the list of graphics styles
<code>//root/Colors</code>	with the list of active colors

For example, if a file `myFile.root` is added to the list of files, one can retrieve a pointer to the corresponding `TFile` object with a statement like:

```
TFile *myFile = (TFile*)gROOT->FindObjectAny("/ROOTFiles/myFile.root");
//or
TFile *myFile = (TFile*)gROOT->FindObjectAny("myFile.root");
```

Tasks

Tasks can be organized into a hierarchy and displayed in the browser. The `TTask` class is the base class from which the tasks are derived. To give task functionality, you need to subclass the `TTask` class and override the `Exec` method. An example of `TTask` subclasses is `$ROOTSYS/tutorials/MyTasks.cxx`. The script that creates a task hierarchy and adds it to the browser is `$ROOTSYS/tutorials/tasks.C`. Here is a part of `MyTasks.cxx` that shows how to subclass from `TTask`.

```
// A set of classes deriving from TTask see macro tasks.C. The Exec
// function of each class prints one line when it is called.
#include "TTask.h"

class MyRun : public TTask {
public:
    MyRun() { ; }
    MyRun(const char *name, const char *title);
    virtual ~MyRun() { ; }
    void Exec(Option_t *option="");
    ClassDef(MyRun,1) // Run Reconstruction task
};

class MyEvent : public TTask {
public:
    MyEvent() { ; }
    MyEvent(const char *name, const char *title);
    virtual ~MyEvent() { ; }
    void Exec(Option_t *option="");
    ClassDef(MyEvent,1) // Event Reconstruction task
};
```

Later in `MyTasks.cxx`, we can see examples of the constructor and overridden `Exec()` method:

```
ClassImp(MyRun)
MyRun::MyRun(const char *name,const char *title):TTask(name,title)
{
  ...
}
void MyRun::Exec(Option_t *option)
{
  printf("MyRun executing\n");
}
```

Each **TTask** derived class may contain other **TTasks** that can be executed recursively. In this way, a complex program can be dynamically built and executed by invoking the services of the top level task or one of its subtasks. The constructor of **TTask** has two arguments: the name and the title. This script creates the task defined above, and creates a hierarchy of tasks.

```
// Show the tasks in a browser. To execute a Task, select
// "ExecuteTask" in the context menu see also other functions in the
// TTask context menu, such as:
//           -setting a breakpoint in one or more tasks
//           -enabling/disabling one task, etc
void tasks()
{
  gROOT->ProcessLine(".L MyTasks.cxx+");

  TTask *run = new MyRun("run","Process one run");
  TTask *event = new MyEvent("event","Process one event");
  TTask *geomInit = new MyGeomInit("geomInit",
                                   "Geometry Initialisation");
  TTask *matInit = new MyMaterialInit("matInit",
                                     "MaterialsInitialisation");
  TTask *tracker = new MyTracker("tracker","Tracker manager");
  TTask *tpc = new MyRecTPC("tpc","TPC Reconstruction");
  TTask *its = new MyRecITS("its","ITS Reconstruction");
  TTask *muon = new MyRecMUON("muon","MUON Reconstruction");
  TTask *phos = new MyRecPHOS("phos","PHOS Reconstruction");
  TTask *rich = new MyRecRICH("rich","RICH Reconstruction");
  TTask *trd = new MyRecTRD("trd","TRD Reconstruction");
  TTask *global = new MyRecGlobal("global","Global Reconstruction");

  // Create a hierarchy by adding sub tasks
  run->Add(geomInit);
  run->Add(matInit);
  run->Add(event);
  event->Add(tracker);
  event->Add(global);
  tracker->Add(tpc);
  tracker->Add(its);
  tracker->Add(muon);
  tracker->Add(phos);
  tracker->Add(rich);
  tracker->Add(trd);

  // Add the top level task
  gROOT->GetListOfTasks()->Add(run);
  // Add the task to the browser
  gROOT->GetListOfBrowsables()->Add(run);
  new TBrowser;
}
```

Note that the first line loads the class definitions in `MyTasks.cxx` with ACLiC. ACLiC builds a shared library and adds the classes to the CINT dictionary (see "How to Add a Class with ACLiC" in the chapter "[Adding a Class](#)")

To execute a `TTask`, you call the `ExecuteTask` method. `ExecuteTask` will recursively call:

- the `TTask::Exec` method of the derived class
- `TTask::ExecuteTasks` to execute for each task the list of its subtasks.

If the top level task is added to the list of ROOT browseable objects, the tree of tasks can be seen in the ROOT browser. To add it to the browser, get the list of browseable objects first and add it to the collection.

```
gROOT->GetListOfBrowsables()->Add(run);
```

The first parameter of the `Add` method is a pointer to a `TTask`, the second parameter is the string to show in the browser. If the string is left out, the name of the task is used.

After executing the script above the browser will look like this.

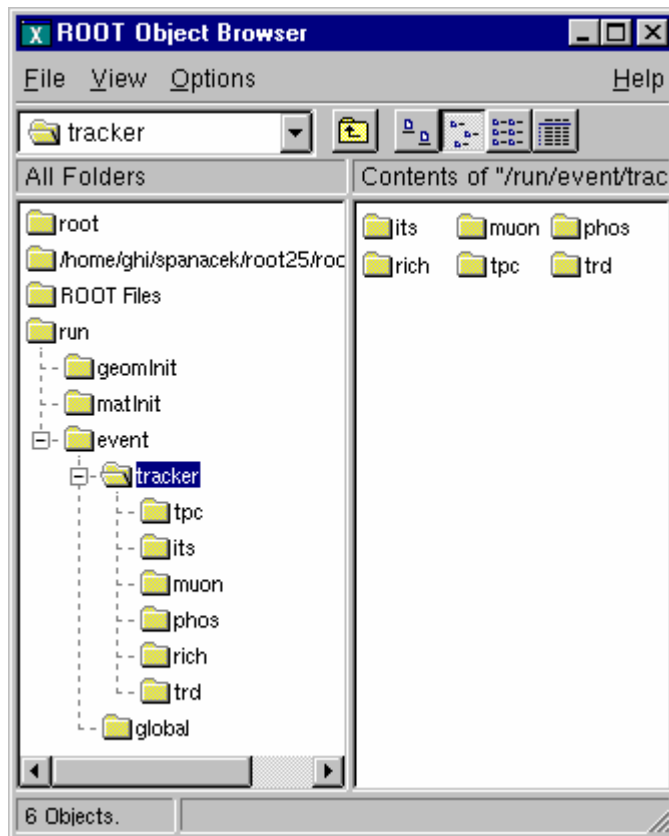

Execute and Debug Tasks

The browser can be used to start a task, set break points at the beginning of a task or when the task has completed. At a breakpoint, data structures generated by the execution up this point may be inspected asynchronously and then the execution can be resumed by selecting the "Continue" function of a task.

A task may be active or inactive (controlled by `TTask::SetActive`). When a task is inactive, its sub tasks are not executed. A task tree may be made persistent, saving the status of all the tasks.

11 Input/Output

This chapter covers the saving and reading of objects to and from ROOT files. It begins with an explanation of the physical layout of a ROOT file. It includes a discussion on compression, and file recovery. Then we explain the logical file, the class `TFile` and its methods. We show how to navigate in a file, how to save objects and read them back. We also include a discussion on `Streamers`. `Streamers` are the methods responsible to capture an objects current state to save it to disk or send it over the network. At the end of the chapter is a discussion on the two specialized ROOT files: `TNetFile` and `TWebFile`.

The Physical Layout of ROOT Files

A ROOT file is like a UNIX file directory. It can contain directories and objects organized in unlimited number of levels. It also is stored in machine independent format (ASCII, IEEE floating point, Big Endian byte ordering).

To look at the physical layout of a ROOT file, we first create one. This example creates a ROOT file and 15 histograms, fills each histogram with 1000 entries from a Gaussian distribution, and writes them to the file.

```
{
char name[10], title[20];
// Create an array of Histograms
TObjArray Hlist(0);
// create a pointer to a histogram
TH1F* h;
// make and fill 15 histograms
// and add them to the object array
for (Int_t i = 0; i < 15; i++) {
    sprintf(name,"h%d",i);
    sprintf(title,"histo nr:%d",i);
    h = new TH1F(name,title,100,-4,4);
    Hlist.Add(h);
    h->FillRandom("gaus",1000);
}
// open a file and write the array to the file
TFile f("demo.root","recreate");
Hlist->Write();
f.Close();
}
```

The example begins with a call to the `TFile` constructor. `TFile` is the class describing the ROOT file. In the next section, when we discuss the logical file structure, we will cover `TFile` in detail. You can also see that the file has the extension `".root"`, this convention is encouraged, and however ROOT does not depend on it.

The last line of the example closed the file. To view its contents it needs to be opened again, and once opened we can view the contents in the ROOT Object browser by creating a `TBrowser` object.

```
root[] TFile f("demo.root")
root[] TBrowser browser;
```

In the browser, we can see the 15 histograms we created.

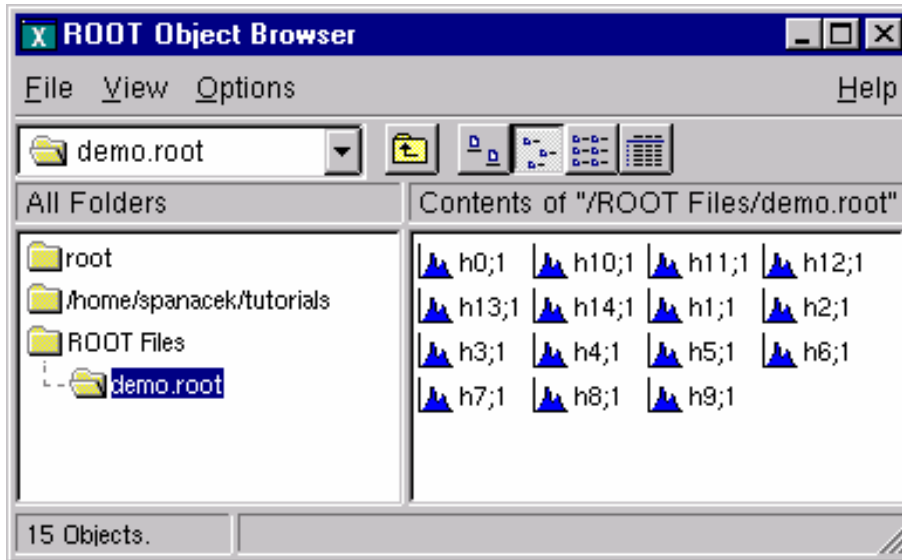

Once we have the `TFile` object, we can call the `TFile::Map()` method to view the physical layout. The output of `Map()` prints the date/time, the start address of the record, the number of bytes in the record, the class name of the record, and the compression factor.

```
root[] f.Map()
20010404/092347 At:64 N=84 TFile
20010404/092347 At:148 N=380 TH1F CX = 2.49
20010404/092347 At:528 N=377 TH1F CX = 2.51
20010404/092347 At:905 N=378 TH1F CX = 2.50
20010404/092347 At:1283 N=376 TH1F CX = 2.52
20010404/092347 At:1659 N=374 TH1F CX = 2.53
20010404/092347 At:2033 N=390 TH1F CX = 2.43
20010404/092347 At:2423 N=380 TH1F CX = 2.49
20010404/092347 At:2803 N=380 TH1F CX = 2.49
20010404/092347 At:3183 N=385 TH1F CX = 2.46
20010404/092347 At:3568 N=374 TH1F CX = 2.53
20010404/092347 At:3942 N=382 TH1F CX = 2.49
20010404/092347 At:4324 N=380 TH1F CX = 2.50
20010404/092347 At:4704 N=387 TH1F CX = 2.45
20010404/092347 At:5091 N=382 TH1F CX = 2.49
20010404/092347 At:5473 N=381 TH1F CX = 2.49
20010404/092347 At:5854 N=2390 StreamerInfo CX = 3.41
20010404/092347 At:8244 N=732 KeysList
20010404/092347 At:8976 N=53 FreeSegments
20010404/092347 At:9029 N=1 END
```

We see the fifteen histograms (`TH1F`'s) with the first one starting at byte 148. We also see an entry `TFile`. You may notice that the first entry starts at byte 64. The first 64 bytes are taken by the file header.

The File Header

This table shows the file header information:

Byte	Value Name	Description
1 -> 4	"root"	Root file identifier
5 -> 8	fVersion	File format version
9 -> 12	fBEGIN	Pointer to first data record
13 -> 16	fEND	Pointer to first free word at the EOF
17 -> 20	fSeekFree	Pointer to FREE data record
21 -> 24	fNbytesFree	Number of bytes in FREE data record
25 -> 28	nfree	Number of free data records
29 -> 32	fNbytesName	Number of bytes in TNamed at creation time
33 -> 33	fUnits	Number of bytes for file pointers
34 -> 37	fCompress	Zip compression level

The first four bytes of the file header contain the string "root" which identifies a file as a ROOT file. Because of this identifier, ROOT is not dependent on the ".root" extension. It is still a good idea to use the extension, just for us to recognize them easier.

The `nfree` and value is the number of free records. A ROOT file has a maximum size of 2 gigabytes. This variable along with `FNbytesFree` keeps track of the free space in terms of records and bytes. This count also includes the deleted records, which are available again.

The Top Directory Description

The 84 bytes after the file header contain the top directory description, including the name, the date and time it was created, and the date and time of the last modification.

20010404/092347	At:64	N=84	TFile
-----------------	-------	------	-------

The Histogram Records

What follows are the 15 histograms, in records of variable length.

20010404/092347	At:148	N=380	TH1F	CX = 2.49
20010404/092347	At:528	N=377	TH1F	CX = 2.51
...				

The first four bytes of each record is an integer holding the number of bytes in this record. A negative number flags the record as deleted, and makes the space available for recycling in the next write. The rest of bytes in the header contain all the information to uniquely identify a data block on the file. This is followed by the object data.

This table explains the values in each individual record:

Record Information		
Byte	Value Name	Description
1 -> 4	Nbytes	Length of compressed object (in bytes)
5 -> 6	Version	TKey version identifier
7 -> 10	ObjLen	Length of uncompressed object
11 -> 14	Datetime	Date and time when object was written to file
15 -> 16	KeyLen	Length of the key structure (in bytes)
17 -> 18	Cycle	Cycle of key
19 -> 22	SeekKey	Pointer to record itself (consistency check)
23 -> 26	SeekPdir	Pointer to directory header
27	lname	Number of bytes in the class name
28->...	ClassName	Object Class Name
...->...	lname	Number of bytes in the object name
...->...	Name	lname bytes with the name of the object
...->...	lTitle	Number of bytes in the object title
...->...	Title	Title of the object
---->	DATA	Data bytes associated to the object

You see a reference to **TKey**. It is explained in detail in the next section.

The Class Description List (StreamerInfo List)

The histogram records are followed by the `StreamerInfo` list of class descriptions. The list contains the description of each class that has been written to file.

```
20010404/092347 At:5854 N=2390 StreamerInfo CX = 3.41
```

The class description is recursive, because to fully describe a class, its ancestors and object data members have to be described also.

In `demo.root`, the class description list contains the description for:

- **TH1F**
- all classes in the **TH1F** inheritance tree
- all classes of the object data members
- all classes in the object data members' inheritance tree.

This description is implemented by the `TStreamerInfo` class, and is often referred to as simply `StreamerInfo`. You can print a file's `StreamerInfo` list with the `TFile::ShowStreamerInfo` method. Below is an example of the output. Only the first line of each class description is shown. The `demo.root` example contains only **TH1F** objects. Here we see the recursive nature of the class description; it contains the `StreamerInfo` of all the classes needed to describe **TH1F**.

```

root[] f.ShowStreamerInfo()
StreamerInfo for class: TH1F, version=1
  BASE      TH1      offset=0 type= 0 1-Dim histogram base class
  BASE      TArrayF   offset=0 type= 0 Array of floats

StreamerInfo for class: TH1, version=3
  BASE      TNamed     offset=0 type=67 The basis for named object(name,title)
  BASE      TAttLine   offset=0 type= 0 Line attributes
  BASE      TAttFill   offset=0 type= 0 Fill area attributes
  BASE      TAttMarker offset=0 type= 0 Marker attributes
  Int_t     fNcells    offset=0 type= 3 number bins(1D),cells(2D)+U/Overflows
  TAxis     fXaxis     offset=0 type=61 X axis descriptor
  TAxis     fYaxis     offset=0 type=61 Y axis descriptor
  TAxis     fZaxis     offset=0 type=61 Z axis descriptor
  Short_t   fBarOffset offset=0 type= 2 (1000*offset) for barcharts or legos
  Short_t   fBarWidth  offset=0 type= 2 (1000*width) for bar charts or legos
  Stat_t    fEntries   offset=0 type= 8 Number of entries
  Stat_t    fTsumw     offset=0 type= 8 Total Sum of weights
  Stat_t    fTsumw2    offset=0 type= 8 Total Sum of squares of weights
  Stat_t    fTsumwx    offset=0 type= 8 Total Sum of weight*X
  Stat_t    fTsumwx2   offset=0 type= 8 Total Sum of weight*X*X
  Double_t  fMaximum   offset=0 type= 8 Maximum value for plotting
  Double_t  fMinimum   offset=0 type= 8 Minimum value for plotting
  Double_t  fNormFactor offset=0 type= 8 Normalization factor
  TArrayD   fContour   offset=0 type=62 Array to display contour levels
  TArrayD   fSumw2     offset=0 type=62 Array of sum of squares of weights
  TString   fOption    offset=0 type=65 histogram options
  TList*    fFunctions offset=0 type=63 ->Pointer to list of functions
                                     (fits and user)

StreamerInfo for class: TNamed, version=1
...
StreamerInfo for class: TAttLine, version=1
...
StreamerInfo for class: TAttFill, version=1
...
StreamerInfo for class: TAttMarker, version=1
...
StreamerInfo for class: TArrayF, version=1
...
StreamerInfo for class: TArray, version=1
...
StreamerInfo for class: TAxis, version=6
...
StreamerInfo for class: TAttAxis, version=4
...

```

ROOT allows a class to have multiple versions, and each version has its own description in form of a `StreamerInfo`. Above you see the class name and version number. The `StreamerInfoList` has only one description for each class/version combination it encountered. The file can have multiple versions of the same class, for example objects of old and new versions of a class can be in the same file. The `StreamerInfos` described in detail in the section on Streamers.

The List of Keys and the List of Free Blocks

The last three entries on the output of `TFile::Map()` are the list of keys, the list of free segments, and the address where the data ends.. When a file is closed, it writes a linked list of keys at the end of the file. This is what we see in the second to last entry. In our example, the list of keys is stored in 732 bytes beginning at byte# 8244.

20010404/092347	At:8244	N=732	KeysList
20010404/092347	At:8976	N=53	FreeSegments
20010404/092347	At:9029	N=1	END

The second to last entry is a list of free segments. In our case, this starts 8976 and is not very long, only 53 bytes, since we have not deleted any objects. The last entry is the address of the last byte in the file.

File Recovery

A file may become corrupted or it may be impossible to write it to disk and close it properly. For example if the file is too large and exceeds the disk quota, or the job crashes or a batch job reaches its time limit before the file can be closed. In these cases, it is imperative to recover and retain as much information as possible. ROOT provides an intelligent and elegant file recovery mechanism using the redundant directory information in the record header.

If the file is not closed due to for example exceed the time limit, and it is opened again, it is scanned and rebuilt according to the information in the record header. The recovery algorithm reads the file and creates the saved objects in memory according to the header information. It then rebuilds the directory and file structure. If the file is opened in write mode, the recovery makes the correction on disk when the file is closed; however if the file is opened in read mode, the correction can not be written to disk. You can also explicitly invoke the recovery procedure by calling the `TFile::Recover()` method. You must be aware of the 2GB size limit before you attempt a recovery. If the file has reached this limit, you cannot add more data. You can still recover the directory structure, but you cannot save what you just recovered to the file on disk. Here we interrupted and aborted the previous ROOT session, causing the file not to be closed. When we start a new session and attempt to open the file, it gives us an explanation and status on the recovery attempt.

```
root[] TFile f("demo.root")
Warning in <TFile::TFile>: file demo.root probably not closed, trying to
recover successfully recovered 15 keys
```

The Logical ROOT File: TFile and TKey

We saw that the `TFile::Map()` method reads the file sequentially and prints information about each record while scanning the file. It is not feasible to only support sequential access and hence ROOT provides random or direct access, i.e. reading a specified object at a time. To do so, `TFile` keeps a list of `TKeys`, which is essentially an index to the objects in the file. The `TKey` class describes the record headers of objects in the file. For example, we can get the list of keys and print them. To find a specific object on the file we can use the `TFile::Get()` method.

```
root[] TFile f("demo.root")
root[] f.GetListOfKeys()->Print()
TKey Name = h0, Title = histo nr:0, Cycle = 1
TKey Name = h1, Title = histo nr:1, Cycle = 1
TKey Name = h2, Title = histo nr:2, Cycle = 1
TKey Name = h3, Title = histo nr:3, Cycle = 1
TKey Name = h4, Title = histo nr:4, Cycle = 1
TKey Name = h5, Title = histo nr:5, Cycle = 1
TKey Name = h6, Title = histo nr:6, Cycle = 1
TKey Name = h7, Title = histo nr:7, Cycle = 1
TKey Name = h8, Title = histo nr:8, Cycle = 1
TKey Name = h9, Title = histo nr:9, Cycle = 1
TKey Name = h10, Title = histo nr:10, Cycle = 1
TKey Name = h11, Title = histo nr:11, Cycle = 1
TKey Name = h12, Title = histo nr:12, Cycle = 1
TKey Name = h13, Title = histo nr:13, Cycle = 1
TKey Name = h14, Title = histo nr:14, Cycle = 1
root[] TH1F *h9 = (TH1F*)f.Get("h9");
```

The `TFile::Get()` finds the `TKey` object with name "h9". Using the `TKey` info it will import in memory the object in the file at the file address #3352 (see the output from the `TFile::Map` above). This is done by the `Streamer` method that is covered in detail in a later section.

Since the keys are available in a **TList** of **TKeys** we can iterate over the list of keys:

```

{
  TFile f("demo.root");
  TIter next(f.GetListOfKeys());
  TKey *key;
  while ((key=(TKey*)next())) {
    printf("key: %s points to an object of class: %s at %d\n",
          key->GetName(),
          key->GetClassName(), key->GetSeekKey());
  }
}

```

The output of this script is:

```

root[] .x iterate.C
key: h0 points to an object of class: TH1F at 150
key: h1 points to an object of class: TH1F at 503
key: h2 points to an object of class: TH1F at 854
key: h3 points to an object of class: TH1F at 1194
key: h4 points to an object of class: TH1F at 1539
key: h5 points to an object of class: TH1F at 1882
key: h6 points to an object of class: TH1F at 2240
key: h7 points to an object of class: TH1F at 2582
key: h8 points to an object of class: TH1F at 2937
key: h9 points to an object of class: TH1F at 3293
key: h10 points to an object of class: TH1F at 3639
key: h11 points to an object of class: TH1F at 3986
key: h12 points to an object of class: TH1F at 4339
key: h13 points to an object of class: TH1F at 4694
key: h14 points to an object of class: TH1F at 5038

```

In addition to the list of keys, **TFile** also keeps two other lists: **TFile::fFree** is a **TList** of free blocks used to recycle freed up space in the file. **ROOT** tries to find the best free block. If a free block matches the size of the new object to be stored, the object is written in the free block and this free block is deleted from the list. If not, the first free block bigger than the object is used. **TFile::fListHead** contains a sorted list (**TSortedList**) of objects in memory. The diagram below illustrates the logical view of the **TFile** and **TKey**.

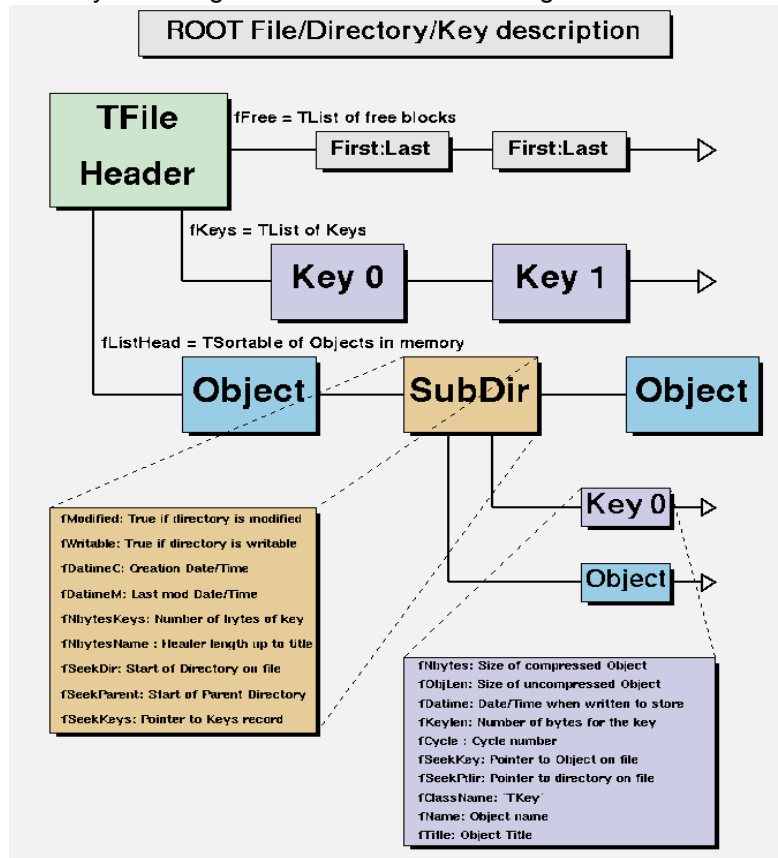

Viewing the Logical File Contents

TFile is a descendent of **TDirectory**, which means it behaves like a **TDirectory**. We can list the contents, print the name, and create subdirectories. In a **ROOT** session, you are always in a directory and the directory you are in is called the current directory and is stored in the global variable *gDirectory*. Let's look at a more detailed example of a **ROOT** file and its role as the current directory. First, we create a **ROOT** file by executing a sample script.

```
root[] .x $ROOTSYS/tutorials/hsimple.C
```

Now you should have `hsimple.root` in your directory. The file was closed by the script so we have to open it again to work with it. We open the file with the intent to update it, and list its contents.

```
root[] TFile f ("hsimple.root", "UPDATE")
root[] f.ls()
TFile** hsimple.root
TFile* hsimple.root
KEY: TH1F hp;1 This is the px distribution
KEY: TH2F hp;1 py vs px
KEY: TProfile hprof;1 Profile of pz versus px
KEY: TNtuple ntuple;1 Demo ntuple
```

It shows the two lines starting with **TFile** followed by four lines starting with the word "KEY". The four keys tell us that there are four objects on disk in this file. The syntax of the listing is:

```
KEY: <class> <variable>;<cycle number> <title>
```

For example, the first line in the list means there is an object in the file on disk, called `hp`. It is of the class **TH1F** (one-dimensional histogram of floating numbers). The object's title is "This is the `px` distribution".

If the line starts with **OBJ**, the object is in memory. The `<class>` is the name of the **ROOT** class (T-something). The `<variable>` is the name of the object. The cycle number along with the variable name uniquely identifies the object. The `<title>` is the string given in the constructor of the object as title.

This picture shows a **TFile** with five objects in the top directory (`kObjA;1`, `kObjA;2`, `kObjB;1`, `kObjD;1` and `kObjC;1`). `ObjA` is on file twice with two different cycle numbers. It also shows four objects in memory (`mObjE`, `mObjF`, `mObjM`, `mObjL`). It also shows several subdirectories.

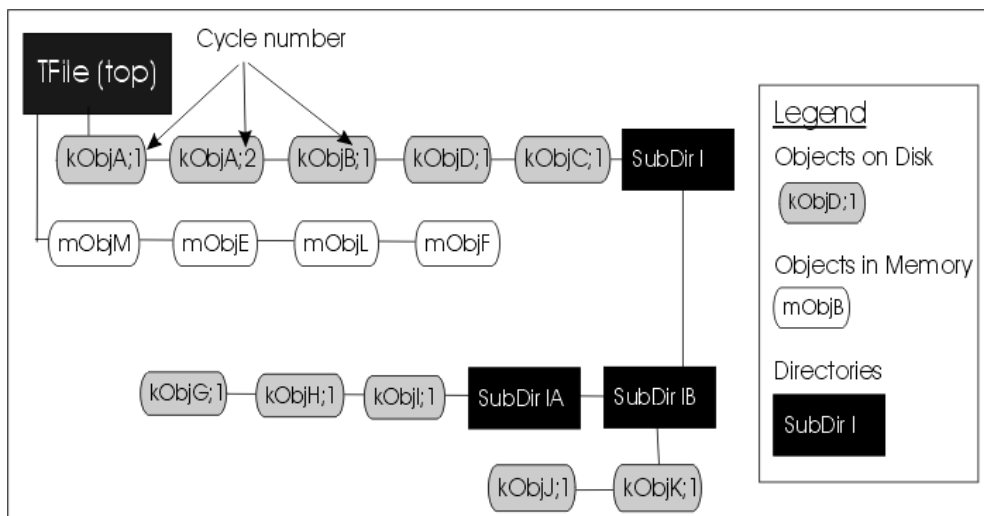

The Current Directory

When you create a `TFile` object, it becomes the current directory. Therefore, the last file to be opened is always the current directory. To check your current directory you can type:

```
root[] gDirectory->pwd()
Rint: /
```

This means that the current directory is the ROOT session (`Rint`). When you create a file, and repeat the command the file becomes the current directory.

```
root[] TFile f1("AFile1.root");
root[] gDirectory->pwd()
AFile1.root: /
```

If you create two files, the last becomes the current directory.

```
root[] TFile f2("AFile2.root");
root[] gDirectory->pwd()
AFile2.root: /
```

To switch back to the first file, or to switch to any file in general, you can use the `TDirectory::cd` method. The next command changes the current directory back to the first file.

```
root[] f1.cd();
root[] gDirectory->pwd()
AFile1.root: /
```

Note that even if you open the file in "READ" mode, it still becomes the current directory. `CINT` also offers a shortcut for `gDirectory->pwd()` and `gDirectory->ls()`, you can type:

```
root[] .pwd
AFile1.root: /
root[] .ls
TFile**      AFile1.root
TFile*       AFile1.root
```

To return back to the home directory where we were before:

```
root[] gROOT->cd()
(unsigned char)1
root[] gROOT->pwd()
Rint: /
```

Objects in Memory and Objects on Disk

The `TFile::ls()` method has an option to list the objects on disk ("-d") or the objects in memory ("-m"). If no option is given it lists both, first the objects in memory, then the objects on disk. For example:

```
root[] TFile *f = new TFile("hsimple.root");
root[] gDirectory->ls("-m")
TFile**      hsimple.root
TFile*       hsimple.root
```

Remember that `gDirectory` is the current directory and at this time is equivalent to "`f`". This correctly states that no objects are in memory.

The next command lists the objects on disk in the current directory.

```
root[] gDirectory->ls("-d")
TFile**      hsimple.root
TFile*       hsimple.root
KEY: TH1F    hpx;1      This is the px distribution
KEY: TH2F    hpxpy;1   py vs px
KEY: TProfile hprof;1  Profile of pz versus px
KEY: TNtuple ntuple;1 Demo ntuple
```

To bring an object from disk into memory, we have to use it or "Get" it explicitly. When we use the object, ROOT gets it for us. Any reference to `hprof` will read it from the file. For example drawing `hprof` will read it from the file and create an object in memory. Here we draw the profile histogram, and then we list the contents.

```
root[] hprof->Draw()
<TCanvas::MakeDefCanvas>: created default TCanvas with name c1
root[] f->ls()
TFile** hsimple.root
TFile*  hsimple.root
OBJ: TProfile hprof Profile of pz versus px : 0
KEY: TH1F hpx;1 This is the px distribution
KEY: TH2F hpxpy;1 py vs px
KEY: TProfile hprof;1 Profile of pz versus px
KEY: TNtuple ntuple;1 Demo ntuple
```

We now see a new line that starts with OBJ. This means that an object of class **TProfile**, called `hprof` has been added in memory to this directory. This new `hprof` in memory is independent from the `hprof` on disk. If we make changes to the `hprof` in memory, they are not propagated to the `hprof` on disk. A new version of `hprof` will be saved once we call `Write`.

You may wonder why `hprof` is added to the objects in the current directory. `hprof` is of the class **TProfile** that inherits from **TH1D**, which inherits from **TH1**. **TH1** is the basic histogram. All histograms and trees are created in the current directory (also see "Histograms and the Current Directory"). The reference to "all histograms" includes objects of any class descending directly or indirectly from **TH1**. Hence, our **TProfile** `hprof` is created in the current directory `f`. There was another side effect when we called the `TH1::Draw` method. CINT printed this statement:

```
<TCanvas::MakeDefCanvas>: created default TCanvas with name c1
```

It tells us that a **TCanvas** was created and it named it `c1`. This is where ROOT is being nice, and it creates a canvas for drawing the histogram if no canvas was named in the draw command, and if no active canvas exists.

The newly created canvas, however, is NOT listed in the contents of the current directory. Why is that? The canvas is not added to the current directory, because by default ONLY histograms and trees are added to the object list of the current directory. Actually, **TEventList** objects are also added to the current directory, but at this time, we don't have to worry about those. If the canvas is not in the current directory then where is it? Because it is a canvas, it was added to the list of canvases. This list can be obtained by the command `gROOT->GetListOfCanvases()->ls()`. The `ls()` will print the contents of the list. In our list, we have one canvas called `c1`. It has a **TFrame**, a **TProfile**, and a **TPaveStats**.

```
root[] gROOT->GetListOfCanvases()->ls()
Canvas Name=c1 Title=c1
Option=TCanvas fXlowNDC=0 fYlowNDC=0 fWNDC=1 fHNDC=1
Name= c1 Title= c1
Option=TFrame X1= -4.000000 Y1=0.000000 X2=4.000000 Y2=19.384882
OBJ: TProfile hprof Profile of pz versus px : 0
TPaveText X1=-4.900000 Y1=20.475282 X2=-0.950000 Y2=21.686837 title
TPaveStats X1=2.800000 Y1=17.446395 X2=4.800000 Y2=21.323371 stats
```

Lets proceed with our example and draw one more histogram, and we see one more OBJ entry.

```

root[] hpx->Draw()
root[] f->ls()
TFile**          hsimple.root
TFile*           hsimple.root
  OBJ: TProfile  hprof  Profile of pz versus px : 0
  OBJ: TH1F     hpx    This is the px distribution : 0
  KEY: TH1F     hpx;1  This is the px distribution
  KEY: TH2F     hpxpy;1 py vs px
  KEY: TProfile hprof;1 Profile of pz versus px
  KEY: f TNtuple ntuple;1      Demo ntuple

```

TFile::ls() loops over the list of objects in memory and the list of objects on disk. In both cases, it calls the **ls()** method of each object. The implementation of the **ls** method is specific to the class of the object, all of these objects are descendants of **TObject** and inherit the **TObject::ls()** implementation. The histogram classes are descendants of **TNamed** that in turn is a descent of **TObject**. In this case, **TNamed::ls()** is executed, and it prints the name of the class, and the name and title of the object. Each directory keeps a list of its objects in the memory. You can get this list by **TDirectory::GetList**. To see the lists in memory contents you can:

```

root[] f->GetList()->ls()
OBJ: TProfile  hprof  Profile of pz versus px : 0
OBJ: TH1F     hpx    This is the px distribution : 0

```

Since the file **f** is the current directory (**gDirectory**), this will yield the same result:

```

root[] gDirectory->GetList()->ls()
OBJ: TProfile  hprof  Profile of pz versus px : 0
OBJ: TH1F     hpx    This is the px distribution : 0

```

Saving Histograms to Disk

At this time, the objects in memory (OBJ) are identical to the objects on disk (KEY). Let's change that by adding a fill to the **hpx** we have in memory.

```

root[] hpx->Fill(0)

```

Now the **hpx** in memory is different from the histogram (**hpx**) on disk. Only one version of the object can be in memory, however, on disk we can store multiple versions of the object. The **TFile::Write** method will write the list of objects in the current directory to disk. It will add a new version of **hpx** and **hprof**.

```

root[] f->Write()
root[] f->ls()
TFile**          hsimple.root
TFile*           hsimple.root
  OBJ: TProfile  hprof  Profile of pz versus px : 0
  OBJ: TH1F     hpx    This is the px distribution : 0
  KEY: TH1F     hpx;2  This is the px distribution
  KEY: TH1F     hpx;1  This is the px distribution
  KEY: TH2F     hpxpy;1 py vs px
  KEY: TProfile hprof;2 Profile of pz versus px
  KEY: TProfile hprof;1 Profile of pz versus px
  KEY: TNtuple  ntuple;1      Demo ntuple

```

The **TFile::Write** method wrote the entire list of objects in the current directory to the file. You see that it added two new keys: **hpx;2** and **hprof;2** to the file. Unlike memory, a file is capable of storing multiple objects with the same name. Their cycle number, the number after the semicolon, differentiates objects on disk with the same name.

This picture shows the file before and after the call to `Write`.

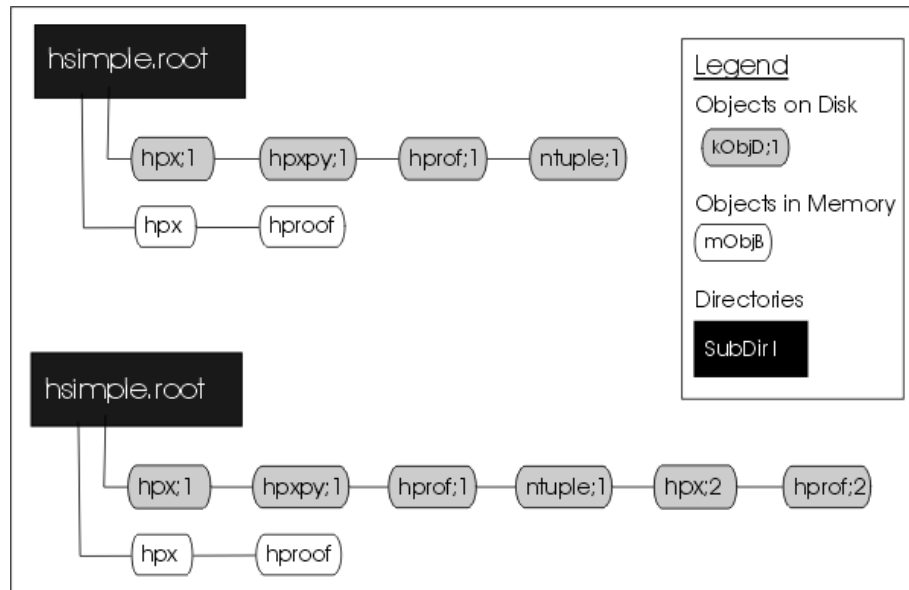

If you wanted to save only `hpx` to the file, but not the entire list of objects, you could use the `TH1::Write` method of `hpx`:

```
root[] hpx->Write ()
```

A call to `obj->Write` without any parameters will call `obj->GetName ()` to find the name of the object and use it to create a key with the same name. You can specify a new name by giving it as a parameter to the `Write` method.

```
root[] hpx->Write ("newName")
```

If you want to re-write the same object, with the same key, use the `overwrite` option.

```
root[] hpx->Write ("", TObject::kOverwrite)
```

If you give a new name and use the `kOverwrite`, the object on disk with the matching name is overwritten if such an object exists. If not, a new object with the new name will be created.

```
root[] hpx->Write ("newName", TObject::kOverwrite)
```

The `Write` method did not affect the objects in memory at all. However, if the file is closed, the directory is emptied and the objects on the list are deleted.

```
root[] f->Close ()
root[] f->ls ()
TFile**    hsimple.root
TFile*     hsimple.root
```

In the code snippet above you can see that the directory is now empty. If you followed along so far, you can see that `c1` which was displaying `hpx` is now blank. Furthermore, `hpx` no longer exists.

```
root[] hpx->Draw ()
Error: No symbol hpx in current scope
```

This is important to remember, do not close the file until you are done with the objects or any attempt to reference the objects will fail.

Histograms and the Current Directory

When a histogram is created, it is added by default to the list of objects in the current directory. You can get the list of histograms in a directory and retrieve a pointer to a specific histogram.

```
*h = (TH1F*)gDirectory->Get("myHist");
```

or

```
TH1F *h = (TH1F*)gDirectory->GetList()->FindObject("myHist");
```

The method **TDirectory::GetList()** returns a **TList** of objects in the directory. You can change the directory of a histogram with the **SetDirectory** method.

```
h->SetDirectory(newDir)
```

If the parameter is 0, the histogram is no longer associated with a directory.

```
h->SetDirectory(0)
```

Once a histogram is removed from the directory, it will no longer be deleted when the directory is closed. It is now your responsibility to delete this histogram object once you are finished with it.

To change the default that automatically adds the histogram to the current directory, you can call the static function:

```
TH1::AddDirectory(kFALSE);
```

In this case, you will need to do all the bookkeeping for all the created histograms.

Saving Objects to Disk

In addition to histograms and trees, you can save any object in a ROOT file. To save a canvas to the ROOT file you can use **TDirectory::Write**.

```
root[] TFile *f = new TFile("hsimple.root", "UPDATE")
root[] hpx->Draw()
<TCanvas::MakeDefCanvas>: created default TCanvas with name c1
root[] c1->Write()
root[] f->ls()
TFile**      hsimple.root
TFile*       hsimple.root
OBJ: TH1F    hpx      This is the px distribution : 0
KEY: TH1F    hpx;2    This is the px distribution
KEY: TH1F    hpx;1    This is the px distribution
KEY: TH2F    hpxpy;1  py vs px
KEY: TProfile hprof;2  Profile of pz versus px
KEY: TProfile hprof;1  Profile of pz versus px
KEY: TNtuple  ntuple;1  Demo ntuple
KEY: TCanvas  c1;1     c1
```

Saving Collections to Disk

All collection classes inherit from **TCollection** and hence inherit the **TCollection::Write** method. When you call **TCollection::Write()** each object in the container is written individually into its own key in the file. To write all objects into one key you can specify the name of the key and use the **TObject::kSingleKey** option.

For example:

```
root[] TList * list = new TList;
root[] TNamed * n1, * n2;
root[] n1 = new TNamed("name1","title1");
root[] n2 = new TNamed("name2","title2");
root[] list->Add(n1);
root[] list->Add(n2);
root[] list->Write("list",TObject::kSingleKey);
```

A TFile Object Going Out of Scope

There is another important point to remember about `TFile::Close` and `TFile::Write`. When a variable is declared on the stack in a function such as in the code below, it will be deleted when it goes out of scope.

```
void foo() { TFile f("Afile.root","RECREATE"); }
```

As soon as the function `foo` has finished executing, the variable `f` is deleted. When a `TFile` object is deleted an implicit call to `TFile::Close` is made. This will save only the file descriptor to disk. It contains: the file header, the `StreamerInfo` list, the key list, the free segment list, and the end address (see "The Physical Layout of ROOT Files").

A `TFile::Close` does not make a call to `Write`, which means that the objects in memory will not be saved in the file.

You need to explicitly call `TFile::Write()` to save the object in memory to file before the exit of the function.

```
void foo() {
    TFile f("Afile.root","RECREATE");
    ... stuff ...
    f->Write();
}
```

To prevent an object in a function from being deleted when it goes out of scope, you can create it on the heap instead of on the stack. This will create a `TFile` object `f`, that is available on a global scope, and it will still be available when exiting the function.

```
void foo() {
    TFile *f = new TFile("Afile.root","RECREATE");
}
```

Retrieving Objects from Disk

If you have a ROOT session running, please quit and start fresh.

We saw that multiple versions of an object with the same name can be in a ROOT file. In our example, we saved a modified histogram `hpx` to the file, which resulted in two `hpx`'s uniquely identified by the cycle number: `hpx;1` and `hpx;2`. The question is how we do retrieve the right version of `hpx`.

When opening the file and using `hpx`, CINT retrieves the one with the highest cycle number.

To read the `hpx;1` into memory, rather than the `hpx;2` we would get by default, we have to explicitly get it and assign it to a variable.

```
root[] TFile *f1 = new TFile("hsimple.root")
root[] TH1F *hpx1 = (TH1F*)f1->Get("hpx;1")
root[] hpx1->Draw()
```

Subdirectories and Navigation

The `TDirectory` class lets you organize its contents into subdirectories, and `TFile` being a descendent of `TDirectory` inherits this ability. Here is an example of a ROOT file with multiple subdirectories as seen in the ROOT browser.

Creating Subdirectories

To add a subdirectory to a file use `TDirectory::mkdir`. The example below opens the file for writing and creates a subdirectory called "Wed011003". Listing the contents of the file shows the new directory in the file and the `TDirectory` object in memory.

```
root[] TFile *f = new TFile("AFile.root", "RECREATE")
root[] f->mkdir("Wed011003")
(class TDirectory*)0x1072b5c8
root[] f->ls()
TFile**      AFile.root
TFile*       AFile.root
TDirectory*  Wed011003      Wed011003
KEY: TDirectory      Wed011003;1      Wed011003
```

Navigating to Subdirectories

We can change the current directory by navigating into the subdirectory, and after changing directory; we can see that `gDirectory` is now "Wed011003".

```
root[] f->cd("Wed011003")
root[] gDirectory->pwd()
AFile.root:/Wed011003
```

In addition to `gDirectory` we have `gFile`, another global that points to the current file. In our example, `gDirectory` points to the subdirectory, and `gFile` points to the file (i.e. the files' top directory).

```
root[] gFile->pwd()
AFile.root:/
```

Use `cd()` without any arguments to return to the file's top directory.

```
root[] f->cd()
AFile.root:/
```

Change to the subdirectory again, and create a histogram. It is added to the current directory, which is the subdirectory "Wed011003".

```
root[] f->cd("Wed011003")
root[] TH1F *histo=new TH1F("histo", "histo", 10, 0, 10);
root[] gDirectory->ls()
TDirectory* Wed011003      Wed011003
OBJ: TH1F      histo      histo : 0
```

If you are in a subdirectory and you would like to have a pointer to the file containing the subdirectory, you can do so:

```
root[] gDirectory->GetFile()
```

If you are in the top directory `gDirectory` is the same as `gFile`. We write the file to save the histogram on disk, to show you how to retrieve it later.

```

root[] f->Write()
root[] gDirectory->ls()
TDirectory*      Wed011003      Wed011003
OBJ: TH1F      histo      histo : 0
KEY: TH1F      histo;1 histo

```

When retrieving an object from a subdirectory, you can navigate to the subdirectory first or give it the path name relative to the file. The read object is created in memory in the current directory. In this first example, we get `histo` from the top directory and the object will be in the top directory.

```

root[] TH1 *h = (TH1*) f->Get("Wed011003/histo;1")

```

If file is written, a copy of `histo` will be in the top directory. This is an effective way to copy an object from one directory to another. In contrast, in the code box below, `histo` will be in memory in the subdirectory because we changed the current directory.

```

root[] f->cd("Wed011003");
root[] TH1 *h = (TH1*) gDirectory->Get("histo;1")

```

Note that there is no warning if the retrieving was not successful. You need to explicitly check the value of `h`, and if it is null, the object could not be found. For example, if you did not give the path name the histogram cannot be found and the pointer to `h` is null:

```

root[] TH1 *h = (TH1*) gDirectory->Get("Wed011003/histo;1")
root[] h
(class TH1*)0x10767de0
root[] TH1 *h = (TH1*) gDirectory->Get("histo;1")
root[] h
(class TH1*)0x0

```

Removing Subdirectories

To remove a subdirectory you need to use `TDirectory::Delete`. There is no `TDirectory::rmdir`. The `Delete` method takes a string containing the variable name and cycle number as a parameter.

```

void Delete(const char *namecycle)

```

The `namecycle` string has the format `name;cycle`.

The next are some rules to remember:

- `name = *` means all, but don't remove the subdirectories
- `cycle = *` means all cycles (memory and file)
- `cycle = ""` means apply to a memory object
- `cycle = 9999` also means apply to a memory object
- `namecycle = ""` means the same as `namecycle = "T"`
- `namecycle = T*` delete subdirectories

For example to delete a directory from a file, you must specify the directory cycle

```

root[] f->Delete("Wed011003;1")

```

Some other examples of `namecycle` format are:

- `foo:` delete the object named `foo` from memory
- `foo;1:` delete the cycle 1 of the object named `foo` from the file
- `foo;*`: delete all cycles of `foo` from the file and also from memory
- `*;2:` delete all objects with cycle number 2 from the file
- `*;*`: delete all objects from memory and from the file
- `T*;*`: delete all objects from memory and from the file including all subdirectories

Streamers

To follow the discussion on `Streamer`, you need to know what a *simple* data type is. A variable is of a simple data type if it cannot be decomposed into other types. Examples of simple data types are longs, shorts, floats, and chars. In contrast, a variable is of a *composite* data type if it can be decomposed. For example, classes, structures, and arrays are composite types. Simple types are also called primitive types, basic types, and CINT sometimes calls them fundamental types.

When we say, "writing an object to a file", we actually mean writing the current values of the data members. The most common way to do this is to decompose (also called the serialization of) the object into its data members and write them to disk. The decomposition is the job of the `Streamer`. Every class with ambitions to be stored in a file has a `Streamer` that decomposes it and "streams" its members into a buffer.

The methods of the class are not written to the file, it contains only the persistent data members.

To decompose the parent classes, the `Streamer` calls the `Streamer` of the parent classes. It moves up the inheritance tree until it reaches an ancestor without a parent.

To serialize the object data members it calls their `Streamer`. They in turn move up their own inheritance tree and so forth.

The simple data members are written to the buffer directly. Eventually the buffer contains all simple data members of all the classes that make up this particular object.

Streaming Pointers

An object pointer data member presents a challenge to the streaming software. If the object pointed to is saved every time it could create circular dependencies and consume large amounts of disk space. The network of references must be preserved on disk and recreated upon reading the file.

When ROOT encounters a pointer data member it calls the `Streamer` of the object and labels it with a unique object identifier. The object identifier is unique for one I/O operation. If there is another reference to the object in the same I/O operation, the first object only referenced by its ID, it is not saved again. When reading the file, the object is rebuilt and the references recalculated. In this way, the network of pointers and their objects is rebuilt and ready to use the same way it was used before it was persistent.

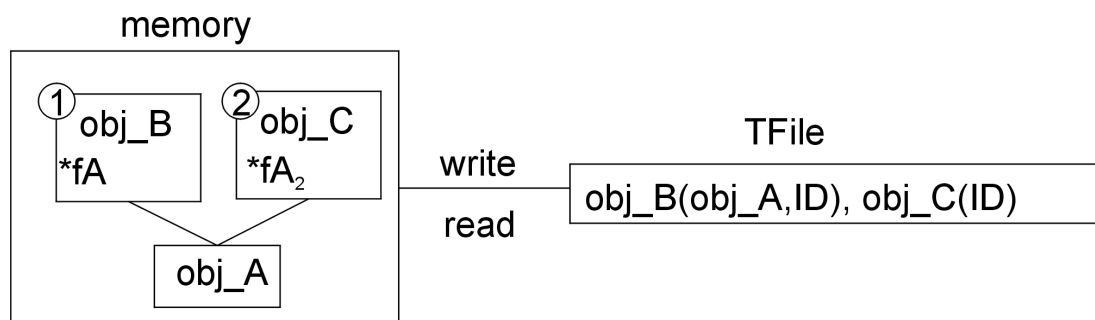

Automatically Generated Streamers

A `Streamer` usually calls other `Streamers`: the `Streamer` of its parents and data members. This architecture depends on all classes having `Streamers`, because eventually they will be called. To ensure that a class has a `Streamer`, `rootcint` automatically creates one in the `ClassDef` macro which is defined in `$ROOTSYS/include/Rtypes.h`. `ClassDef` defines several methods for any class, and one of them is the `Streamer`. The automatically generated `Streamer` is complete and can be used as long as no customization is needed.

The `Event` class is defined in `$ROOTSYS/test/Event.h`. Looking at the class definition, we find that it inherits from `TObject`. It is a simple example of a class with diverse data members.

```
class Event : public TObject {
private:
    TDirectory      *fTransient;          ///! current directory
    Float_t         fPt;                  ///! transient value
    char            fType[20];
    Int_t           fNtrack;
    Int_t           fNseg;
    Int_t           fNvertex;
    UInt_t          fFlag;
    Float_t         fTemperature;
    EventHeader     fEvtHdr;              ///|| don't split
    TClonesArray    *fTracks;            ///->
    TH1F            *fH;                  ///->
    Int_t           fMeasures[10];
    Float_t         fMatrix[4][4];
    Float_t         *fClosestDistance;    ///[fNvertex]
    ...
}
```

The `Event` class is added to the CINT dictionary by the `rootcint` utility. This is the `rootcint` statement in the `$ROOTSYS/test/Makefile`:

```
@rootcint -f EventDict.cxx -c Event.h EventLinkDef.h
```

The `EventDict.cxx` file contains the automatically generated Streamer for `Event`:

```
void Event::Streamer(TBuffer &R__b)
{
    // Stream an object of class Event.
    if (R__b.IsReading()) {
        Event::Class()->ReadBuffer(R__b, this);
    } else {
        Event::Class()->WriteBuffer(R__b, this);
    }
}
```

When writing an `Event` object, `TClass::WriteBuffer` is called. `WriteBuffer` writes the current version number of the `Event` class, and its contents into the buffer `R__b`. The Streamer calls `TClass::ReadBuffer` when reading an `Event` object. The `ReadBuffer` method reads the information from buffer `R__b` into the `Event` object.

Transient Data Members (///)

To prevent a data member from being written to the file, insert a `///` as the first character after the comment marks. For example, in this version of `Event`, the `fPt` and `fTransient` data members are not persistent.

```
class Event : public TObject {
private:
    TDirectory      *fTransient;          ///! current directory
    Float_t         fPt;                  ///! transient value
    ...
}
```

The Pointer to Objects (//->)

The string "->" in the comment field of the members `*fH` and `*fTracks` instruct the automatic `Streamer` to assume these will point to valid objects and the `Streamer` of the objects can be called rather than the more expensive `R__b << fH`.

```
TClonesArray *fTracks;          //->
TH1F         *fH;              //->
```

Variable Length Array

When the `Streamer` comes across a pointer to a simple type, it assumes it is an array. Somehow, it has to know how many elements are in the array to reserve enough space in the buffer and write out the appropriate number of elements. This is done in the class definition. For example:

```
class Event : public TObject {
private:
    char          fType[20];
    Int_t         fNtrack;
    Int_t         fNseg;
    Int_t         fNvertex;
    ...
    Float_t       *fClosestDistance;  //[fNvertex]
```

The array `fClosestDistance` is defined as a pointer of floating point numbers. A comment mark (`//`), and the number in square brackets tell the `Streamer` the length of the array for this object. In general the syntax is:

```
<simple type>    *<name>    //[<length>]
```

The length cannot be an expression. If a variable is used, it needs to be an integer data member of the class. It must be defined ahead of its use, or in a base class.

Prevent Splitting (//|)

If you want to prevent a data member from being split when writing it to a tree, append the characters `|` right after the comment string. This only makes sense for object data members. For example:

```
EventHeader    fEvtHdr;          //| do not split the header
```

Streamers with Special Additions

Most of the time you can let `rootcint` generate a `Streamer` for you. However if you want to write your own `Streamer` you can do so.

For some classes, it may be necessary to execute some code before or after the read or write block in the automatic `Streamer`. For example after the execution of the read block, one can initialize some non persistent members.

There are two reasons why you would need to write your own `Streamer`. If you have a complex STL container type data member that is not yet supported by `ROOT`, or if you have a non-persistent data member that you want to initialize to a value depending on the read data members. In addition, the automatic `Streamer` does not support C-structures. It is best to convert the structure to a class definition.

First, you need to tell `rootcint` not to build a `Streamer` for you. The input to the `rootcint` command (in the `makefile`) is a list of classes in a `LinkDef.h` file. For example, the list of classes for `Event` is listed in `$ROOTSYS/test/EventLinkDef.h`. The "-" at the end of the class name tells `rootcint` not to generate a `Streamer`.

In the example, you can see the `Event` class is the only one for which `rootcint` is instructed not to generate a `Streamer` .

```
#ifndef __CINT__

#pragma link off all globals;
#pragma link off all classes;
#pragma link off all functions;

#pragma link C++ class EventHeader+;
#pragma link C++ class Event-;
#pragma link C++ class HistogramManager+;
#pragma link C++ class Track+;

#endif
#pragma link C++ class EventHeader+;
```

The "+" sign tells `rootcint` to use the new `Streamer` system introduced in ROOT 3.0. The following is an example of a customized `Streamer` for `Event`. The `Streamer` takes a `TBuffer` as a parameter, and first checks to see if this is a case of reading or writing the buffer.

```
void Event::Streamer(TBuffer &R__b)
{
    if (R__b.IsReading()) {
        Event::Class()->ReadBuffer(R__b, this);
        fTransient = gDirectory; //save current directory
        fPt= TMath::Sqrt(fPx*fPx + fPy*fPy + fPz*fPz);
    } else {
        Event::Class()->WriteBuffer(R__b, this);
    }
}
```

Writing Objects

The `Streamer` decomposes the objects into data members and writes them to a buffer. It does not write the buffer to a file, it simply populates a buffer with bytes representing the object. This allows us to write the buffer to a file or do anything else we could do with the buffer. For example, we can write it to a socket to send it over the network. This is beyond the scope of this chapter, but it is worthwhile to emphasize the need and advantage of separating the creation of the buffer from its use. Let's look how a buffer is written to a file.

A class needs to inherit from `TObject` or use `TDirectory->Write(obj)` to be saved to disk. However, a class that is a data member of another class does not have to inherit from `TObject`; it only has to have a `Streamer`. `EventHeader` is an example of such a case.

The `TObject::Write` method does the following:

1. Creates a `TKey` object in the current directory
2. Creates a `TBuffer` object which is part of the newly created `TKey`
3. Fills the `TBuffer` with a call to the `class::Streamer` method
4. Creates a second buffer for compression, if needed
5. Reserves space by scanning the `TFree` list. At this point, the size of the buffer is known.
6. Writes the buffer to the file
7. Releases the `TBuffer` part of the key

In other words, the `TObject::Write` calls the `Streamer` method of the class to build the buffer. The buffer is in the key and the key is written to disk. Once written to disk the memory consumed by the buffer part is released. The key part of the `TKey` is kept. The

key consumes about 60 bytes, where the buffer since it contains the object data can be very large. This is a diagram of a streamed **TH1F** in the buffer:

(TH1F (TH1 (TNamed) (TAttLine) (TAttMarker) (TAxis (TNamed) (TAttAxis)) (TAxis (TNamed) (TAttAxis)) (TAxis (TNamed) (TAttAxis)))(TArrayF)

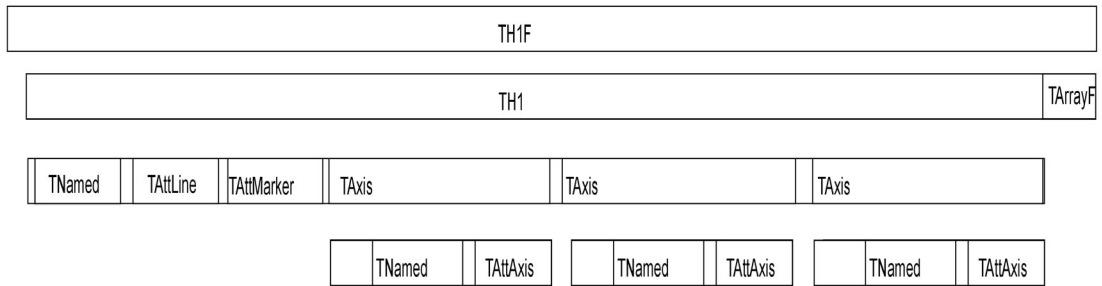

Ignore Object Streamers

You can instruct your class to ignore the **TObject** Streamer with the `MyClass->Class::IgnoreObjectStreamer` method. When the class `kIgnoreTObjectStreamer` bit is set (by calling the `IgnoreTObjectStreamer` method), the automatically generated Streamer will not call `TObject::Streamer`, and the **TObject** part of the class is not streamed to the file. This is useful in case you do not use the **TObject** `fBits` and `fUniqueID` data members. You gain space on the file, and you do not lose functionality if you do not use the `fBits` and `fUniqueID` (see the section on **TObject** on the use of `fBits` and `fUniqueID`).

Streaming a TClonesArray

When writing a **TClonesArray** it bypasses by default the Streamer of the member class and uses a more efficient internal mechanism to write the members to the file. You can override the default and specify that the member class Streamer is used by setting the `TClonesArray::BypassStreamer` bit to false:

```
TClonesArray *fTracks;
fTracks->BypassStreamer(kFALSE); // use the member Streamer
```

When the `kBypassStreamer` bit is set, the automatically generated Streamer can call `TClass::WriteBuffer` directly. Bypassing the Streamer improves the performance when writing/reading the objects in the **TClonesArray**. However, the drawback is: when a **TClonesArray** is written with `split=0` bypassing the Streamer, the `StreamerInfo` of the class in the array being optimized, one cannot later use the **TClonesArray** with `split>0`.

For example, there is a problem with the following scenario:

- 1- a class `Foo` has a **TClonesArray** of `Bar` objects
- 2- the `Foo` object is written with `split=0` to `Tree T1`.
In this case the `StreamerInfo` for the class `Bar` is created in optimized mode in such a way that data members of the same type are written as an array improving the I/O performance.
- 3- in a new program, `T1` is read and a new `Tree T2` is created with the object `Foo` in `split>1`.

When the `T2` branch is created, the `StreamerInfo` for the class `Bar` is created with no optimization (mandatory for the `split` mode). The optimized `Bar` `StreamerInfo` is going to be used to read the **TClonesArray** in `T1`. The result will be `Bar` objects with data member values not in the right sequence. The solution to this problem is to call `BypassStreamer(kFALSE)` for the **TClonesArray**. In this case, the normal `Bar::Streamer` function will be called. The `Bar::Streamer` function works OK independently if the `Bar` `StreamerInfo` had been generated in optimized mode or not.

Pointers and References in Persistency

An object pointer data member presents a challenge to the streaming software. If the object pointed to is saved every time, it could create circular dependencies and consume a large amount of disk space. The network of references must be preserved on disk and recreated upon reading the file.

If you use independent I/O operations for pointers and their referenced object you can use the `TRef` class. Later in this section is an example that compares disk space, memory usage, and I/O times of C++ pointers and `TRefs`. In general, a `TRef` is faster than C++ but the advantage of a C++ pointer is that it is already C++.

Streaming C++ Pointers

When ROOT encounters a pointer data member it calls the `Streamer` of the object and labels it with a unique object identifier. The object identifier is unique for one I/O operation. If there is another pointer to the object in the same I/O operation, the first object is referenced i.e. it is not saved again. When reading the file, the object is rebuilt and the references recalculated.

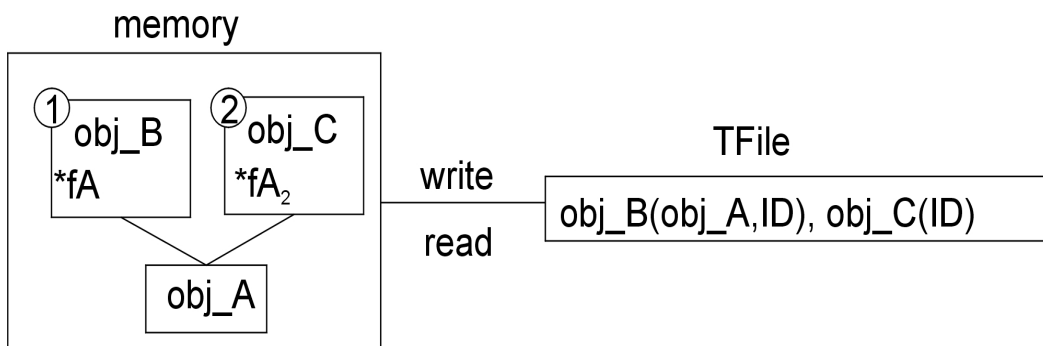

In this way, the network of pointers and their objects is rebuilt and ready to use the same way it was used before it was persistent.

Motivation for the TRef Class

If the object is split into several files or into several branches of one or more `TTrees`, standard C++ pointers cannot be used because each I/O operation will write the referenced objects, and multiple copies will exist. In addition, if the pointer is read before the referenced object, it is null and may cause a run time system error.

To address these limitations, ROOT offers the `TRef` class. `TRef` allows referencing an object in a different branch and/or in a different file. `TRef` also supports the complex situation where a `TFile` is updated multiple times on the same machine or a different machine.

When a `TRef` is read before its referenced object, it is null. As soon as the referenced object is read, the `TRef` points to it. In addition, one can specify an action to be taken by `TRef` in the case it is read before its reference object (see Action on Demand below).

Using TRef

A `TRef` is a lightweight object pointing to any `TObject`. This object can be used instead of normal C++ pointers in case

- The referenced object R and the pointer P are not written to the same file
- P is read before R
- R and P are written to different Tree branches

Below is a line from the example in \$ROOTSYS/test/Event.cxx.

```
TRef fLastTrack; //pointer to last track
...
Track *track = new(tracks[fNtrack++])Track(random);
// Save reference to last Track in the collection of Tracks
fLastTrack = track;
```

The `track` and its reference `fLastTrack` can be written with two separate I/O calls in the same or in different files, in the same or in different branches of a **TTree**. If the **TRef** is read and the referenced object has not yet been read, **TRef** will return a null pointer. As soon as the referenced object will be read, **TRef** will point to it.

How Does It Work?

A **TRef** is itself a **TObject** with an additional transient pointer `fPID`. When a **TRef** is used to point to a **TObject** *R, for example in a class with

```
TRef P;
```

one can do:

```
P = R; //to set the pointer
```

When the statement `P = R` is executed, the following happens:

- The pointer `fPID` is set to the current **TProcessID** (see below).
- The current `ObjectNumber` (see below) is incremented by one.
- `R.fUniqueID` is set to `ObjectNumber`.
- In the `fPID` object, the element `fObjects[ObjectNumber]` is set to `P`
- `P.fUniqueID` is also set to `ObjectNumber`.

After having set `P`, one can immediately return the value of `R` using `P.GetObject()`. This function returns the `fObjects[fUniqueID]` from the `fPID` object.

When the **TRef** is written, the process id number `pidf` of `fPID` is written in addition to the **TObject** part of **TRef** (`fBits`, `fUniqueID`).

When the **TRef** is read, its pointer `fPID` is set to the value stored in the **TObjArray** of **TFile::fProcessIDs** (`fProcessIDs[pidf]`).

When a referenced object is written, **TObject::Streamer** writes the `pidf` in addition to the standard `fBits` and `fUniqueID`.

When **TObject::Streamer** reads a reference object, the `pidf` is read. At this point, the referenced object is entered into the table of objects of the **TProcessID** corresponding to `pidf`.

WARNING: If `MyClass` is the class of the referenced object, The **TObject** part of `MyClass` must be streamed. One should not call `MyClass::Class()->IgnoreTObjectStreamer()`

TProcessID and TUUID

A **TProcessID** uniquely identifies a ROOT job. The **TProcessID** title consists of a **TUUID** object, which provides a globally unique identifier.

The **TUUID** class implements the UUID (Universally Unique Identifier), also known as GUID (Globally Unique Identifier). A UUID is 128 bits long, and if generated according to this algorithm, is either guaranteed to be different from all other UUID generated until 3400 A.D. or extremely likely to be different.

The **TROOT** constructor automatically creates a **TProcessID**. When a **TFile** contains referenced objects, the **TProcessID** object is written to the file. If a file has been

written in multiple sessions (same machine or not), a **TProcessID** is written for each session. The **TProcessID** objects are used by **TRef** to uniquely identify the referenced **TObject**.

When a referenced object is read from a file (its bit `kIsReferenced` is set), this object is entered into the objects table of the corresponding **TProcessID**. Each **TFile** has a list of **TProcessIDs** (see **TFile::fProcessIDs**) also accessible via **TProcessID::fgPIDs** (for all files). When this object is deleted, it is removed from the table via the cleanup mechanism invoked by the **TObject** destructor. Each **TProcessID** has a table (**TObjArray *fObjects**) that keeps track of all referenced objects. If a referenced object has a `fUniqueID`, a pointer to this unique object may be found via `fObjects->At(fUniqueID)`. In the same way, when a **TRef::GetObject** is called, `GetObject` uses its own `fUniqueID` to find the pointer to the referenced object. See **TProcessID::GetObjectWithID** and **PutObjectWithID**.

Object Number

When an object is referenced, a unique identifier is computed and stored in both the `fUniqueID` of the referenced and referencing object. This `uniqueID` is computed by incrementing by one the static global in **TProcessID::fgNumber**. `fUniqueID` is some sort of serial object number in the current session. One can retrieve at any time the current value of `fgNumber` by calling the static function **TProcessID::GetObjectCount** or set this number via **TProcessID::SetObjectCount**. To avoid a growing table of `fObjects` in **TProcessID**, in case, for example, one processes many events in a loop, it might be necessary to reset the `ObjectNumber` at the end of processing of one event. See an example in `$ROOTSYS/test/Event.cxx` (look at function `Build`).

The value of `ObjectNumber` may be saved at the beginning of one event and reset to this original value at the end of the event. These actions may be nested.

```
saveNumber = TProcessID::GetObjectCount();
...
TProcessID::SetObjectCount(savedNumber);
```

Action on Demand

The normal behavior of a **TRef** has been described above. In addition, **TRef** supports "Actions on Demand". It may happen that the object referenced is not yet in memory, on a separate file or not yet computed. In this case, **TRef** is able to automatically execute an action:

- Call to a compiled function (static function of member function)
- Call to an interpreted function
- Execution of a CINT script

How to select this option?

In the definition of the **TRef** data member in the original class, do:

```
TRef fRef; //EXEC:execName points to something
```

When the special keyword "EXEC:" is found in the comment field of the member, the next string is assumed to be the name of a **TExec** object. When a file is connected, the dictionary of the classes on the file is read in memory (see **TFile::ReadStreamInfo**). When the **TStreamerElement** object is read, a **TExec** object is automatically created with the name specified after the keyword "EXEC:" in case a **TExec** with a same name does not already exist.

The action to be executed via this **TExec** can be specified with:

- A call to the **TExec** constructor, if the constructor is called before
- Opening the file.
- A call to **TExec::SetAction** at any time.

One can compute a pointer to an existing **TExec** with a name with:

```
TExec *myExec = gROOT->GetExec(execName);
myExec->SetAction(actionCommand);
```

`actionCommand` is a string containing a CINT instruction.

Examples:

```
myExec->SetAction("LoadHits()");
myExec->SetAction(".x script.C");
```

When a **TRef** is de-referenced via **TRef::GetObject**, its **TExec** is automatically executed. The **TExec** function/script can do one or more of the following:

- Load a file containing the referenced object. This function typically looks in the file catalog (GRID).
- Compute a pointer to the referenced object and communicate this pointer back to the calling function **TRef::SetObject** via:

```
TRef::SetObject(object)
```

As soon as an object is returned to `GetObject`, the `fUniqueID` of the **TRef** is set to the `fUniqueID` of the referenced object. At the next call to `GetObject`, the pointer stored in `fPid:fObjects[fUniqueID]` will be returned directly. An example of action on demand is in `$ROOTSYS/test/Event.h`:

```
TRef fWebHistogram; //EXEC:GetWebHistogram
```

When calling `fWebHistogram.GetObject()`, the function `GetObject` will automatically invoke the script `GetWebHistogram.C` via the interpreter. An example of a `GetWebHistogram.C` script is shown below:

```
void GetWebHistogram() {
    TFile *f=TFile::Open("http://root.cern.ch/files/pippa.root");
    f->cd("DM/CJ");
    TH1 *h6 = (TH1*)gDirectory->Get("h6");
    h6->SetDirectory(0);
    delete f;
    TRef::SetObject(h6);
}
```

In the above example, a call to `fWebHistogram.GetObject()` executes the script with the function `GetWebHistogram`. This script connects a file with histograms: `pippa.root` on the ROOT Web site and returns the object `h6` to **TRef::GetObject**.

```
TRef fWebHistogram; //EXEC:GetWebHistogram()
```

Note that if the definition of the **TRef** `fWebHistogram` had been changed the compiled or interpreted function `GetWebHistogram()` would have been called instead of the CINT script `GetWebHistogram.C`.

Array of TRef

When storing multiple **TRef**(s), it is more efficient to use a **TRefArray**. The efficiency is due to having a single pointer `fPID` for all **TRef**s in the array. It has a dynamic compact table of `fUniqueIDs`. We recommend that you use a **TRefArray** rather than a collection of **TRef**s.

Example:

- Suppose a **TObjArray** `*mytracks` containing a list of `Track` objects.
- Suppose a **TRefArray** `*pions` containing pointers to the pion tracks in `mytracks`. This list is created with statements like: `pions->Add(track);`
- Suppose a **TRefArray** `*muons` containing pointers to the muon tracks in `mytracks`.

The 3 arrays `mytracks`, `pions` and `muons` may be written separately.

Schema Evolution

Schema evolution is a problem faced by long-lived data. When a schema changes, existing persistent data can become inaccessible unless the system provides a mechanism to access data created with previous versions of the schema.

In the lifetime of collaboration, the class definitions (i.e. the schema) are likely to change frequently. Not only can the class itself change, but any of its parent classes or data member classes can change also. This makes the support for schema evolution necessary.

ROOT fully supports schema evolution. The diagram below illustrates some of the scenarios.

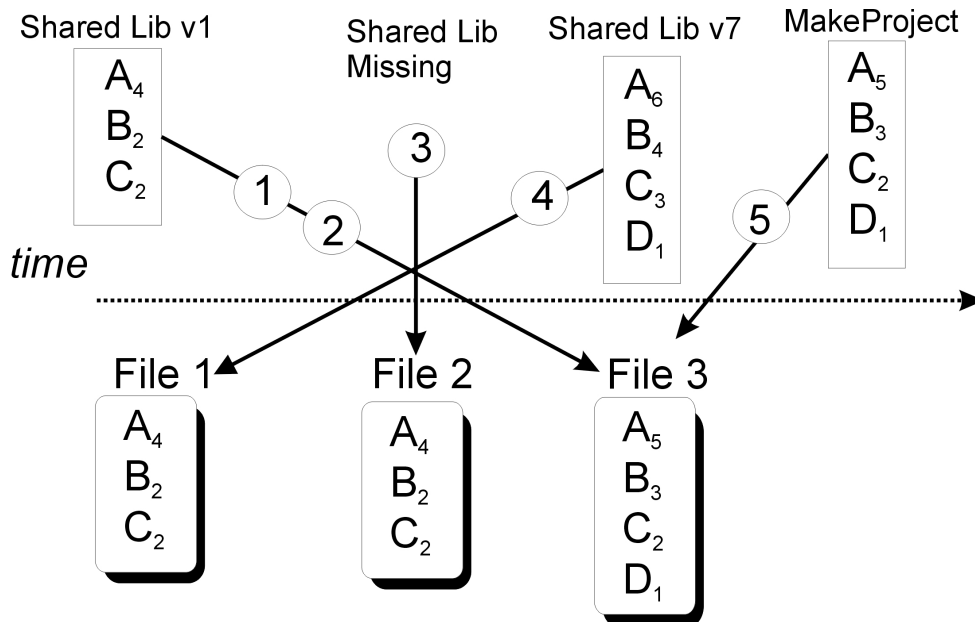

The top half represents different versions of the shared library with the class definitions. These are the in-memory class versions. The bottom half represents data files that contain different versions of the classes.

- 1) An old version of a shared library and a file with new class definitions. This can be the case when someone has not updated the library and is reading a new file.
- 2) Reading a file with a shared library that is missing a class definition (i.e. missing class D).
- 3) Reading a file without any class definitions. This can be the case where the class definition is lost, or unavailable.
- 4) The current version of a shared library and an old file with old class versions (backward compatibility). This is often the case when reading old data.
- 5) Reading a file with a shared library built with `MakeProject`. This is the case when someone has already read the data without a shared library and has used ROOT `MakeProject` feature to reconstruct the class definitions and shared library (`MakeProject` is explained in detail later on).

In case of a mismatch between the in-memory version and the persistent version of a class, ROOT maps the persistent one to the one in memory. This allows you to change the class definition at will, for example:

- 1) Change the order of data members in the class.
- 2) Add new data members. By default the value of the missing member will be 0 or in case of an object it will be set to null.
- 3) Remove data members.
- 4) Move a data member to a base class or vice –versa.
- 5) Change the type of a member if it is a simple type or a pointer to a simple type. If a loss of precision occurs, a warning is given.
- 6) Add or remove a base class

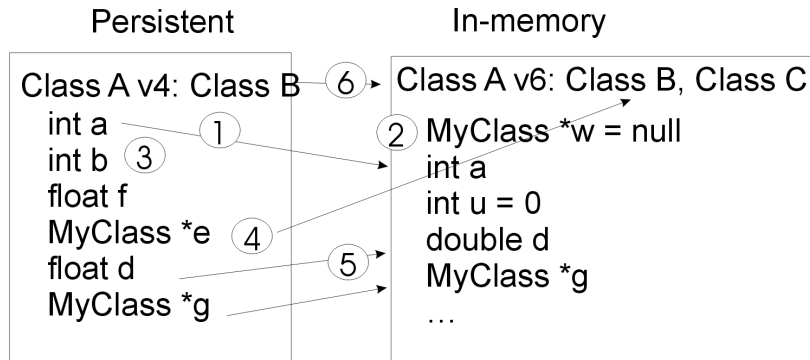

ROOT supports schema evolution by keeping a class description of each version of the class that was ever written to disk, with the class. When it writes an object to file, it also writes the description of the current class version along with it. This description is implemented in the `StreamerInfo` class.

The TStreamerInfo Class

Each class has a list of `StreamerInfo` objects, one for each version of the class if that version was written to disk at least once. When reading an object from a file, the system uses the `StreamerInfo` list to decode an object into the current version. The `StreamerInfo` is made up of `TStreamerElements`. Each describes one persistent data member of the class. By default all data members of a class are persistent. To exclude a data member (i.e. make it not persistent), add a "!" after the comment marks. For example the pointer `*fPainter` of a `TH1` is not persistent:

```
TVirtualHistPainter* fPainter //!pointer to histogram painter
```

The TStreamerElement Class

A `TStreamerElement` describes a data member of a simple type, object, array, pointer, or container. The offset in the `TStreamerElement` is the starting address of the data for that data member.

BASE	TNamed	offset= 0	type=67	The basis for a named object
BASE	TAttLine	offset= 28	type= 0	Line attributes

In this example, the `TNamed` data starts at byte 0, and `TAttLine` starts at byte 28. The offset is machine and compiler dependent and is computed when the `StreamerInfo` is analyzed. The `TClass::GetStreamerInfo` method analyzes the `StreamerInfo` the same way it would be analyzed by referring to the class. While analyzing the `StreamerInfo`, it computes the offsets. The type field is the type of the `TStreamerElement`. It is specific to the `StreamerInfo` definition.

The types are defined in the file `TStreamerInfo.h` and listed here:

```
enum EReadWrite {
    kBase=0,          kChar=1,          kShort=2,          kInt=3,           kLong=4,
    kFloat=5,        kCounter=6,       kCharStar=7,      kDouble=8,       kUChar=11,
    kUShort=12,      kUInt=13,         kULong=14,        kBits=15,        kOffsetL=20,
    kOffsetP=40,     kObject=61,       kAny=62,          kObjectp=63,     kObjectP=64,
    kTString=65,     kTObject=66,      kTNamed=67,       kSkip=100,       kSkipL=120,
    kSkipP=140,     kConv=200,        kConvL=220,       kConvP=240,     kStreamer=500,
    kStreamLoop=501, kMissing=99999
};
```

Example: TH1 StreamerInfo

In the `StreamerInfo` of the **TH1** class we see the four base classes: **TNamed**, **TAttLine**, **TAttFill**, and **TAttMarker**. These are followed by a list of the data members. Each data member is implemented by a **TStreamerElement** object.

```
root[] TH1::Class()->GetStreamerInfo()->ls()
StreamerInfo for class: TH1, version=3
BASE      TNamed      offset= 0 type=67 The basis for a named object
BASE      TAttLine   offset= 28 type= 0 Line attributes
BASE      TAttFill  offset= 40 type= 0 Fill area attributes
BASE      TAttMarker offset= 48 type= 0 Marker attributes
Int_t     fNcells   offset= 60 type= 3 number of bins(1D
TAxis     fXaxis    offset= 64 type=61 X axis descriptor
TAxis     fYaxis    offset=192 type=61 Y axis descriptor
TAxis     fZaxis    offset=320 type=61 Z axis descriptor
Short_t   fBarOffset offset=448 type= 2(1000*offset)for bar charts or legos
Short_t   fBarWidth  offset=450 type= 2 (1000*width)for bar charts or legos
Stat_t    fEntries   offset=452 type= 8 Number of entries
Stat_t    fTsumw     offset=460 type= 8 Total Sum of weights
Stat_t    fTsumw2    offset=468 type= 8 Total Sum of squares of weights
Stat_t    fTsumwx    offset=476 type= 8 Total Sum of weight*X
Stat_t    fTsumwx2   offset=484 type= 8 Total Sum of weight*X*X
Double_t  fMaximum   offset=492 type= 8 Maximum value for plotting
Double_t  fMinimum   offset=500 type= 8 Minimum value for plotting
Double_t  fNormFactor offset=508 type= 8 Normalization factor
TArrayD   fContour   offset=516 type=62 Array to display contour levels
TArrayD   fSumw2     offset=528 type=62 Array of sum of squares of weights
TString   fOption    offset=540 type=65 histogram options
TList*    fFunctions  offset=548 type=63 ->Pointer to list of functions
i= 0, TNamed      type= 67, offset= 0, len=1, method=0
i= 1, TAttLine    type= 0, offset= 28, len=1, method=142484480
i= 2, TAttFill    type= 0, offset= 40, len=1, method=142496992
i= 3, TAttMarker  type= 0, offset= 48, len=1, method=142509704
i= 4, fNcells     type= 3, offset= 60, len=1, method=0
i= 5, fXaxis      type= 61, offset= 64, len=1, method=1081287424
i= 6, fYaxis      type= 61, offset=192, len=1, method=1081287548
i= 7, fZaxis      type= 61, offset=320, len=1, method=1081287676
i= 8, fBarOffset  type= 22, offset=448, len=2, method=0
i= 9, fEntries    type= 28, offset=452, len=8, method=0
i=10, fContour    type= 62, offset=516, len=1, method=1081287804
i=11, fSumw2     type= 62, offset=528, len=1, method=1081287924
i=12, fOption     type= 65, offset=540, len=1, method=1081288044
i=13, fFunctions  type= 63, offset=548, len=1, method=1081288164
```

Optimized StreamerInfo

The entries starting with "i = 0" is the optimized format of the `StreamerInfo`. Consecutive data members of the same simple type and size are collapsed and read at once into an array for performance optimization.

```
i= 0, TNamed      type= 67, offset= 0, len=1, method=0
i= 1, TAttLine   type= 0, offset= 28, len=1, method=142484480
i= 2, TAttFill   type= 0, offset= 40, len=1, method=142496992
i= 3, TAttMarker type= 0, offset= 48, len=1, method=142509704
```

For example, the five data members beginning with `fEntries` and the three data members beginning with `fMaximum`, are put into an array called `fEntries` (i = 9) with the length 8.

```
i= 9, fEntries   type= 28, offset=452, len=8, method=0
```

Only simple type data members are combined, object data members are not combined. For example the three axis data members remain separate. The "method" is a handle to the method that reads the object.

Automatic Schema Evolution

When a class is defined in ROOT, it must include the `ClassDef` macro as the last line in the header file inside the class definition. The syntax is:

```
ClassDef (<ClassName>, <VersionNumber>)
```

The version number identifies this particular version of the class. The version number is written to the file in the Streamer by the call `TBuffer::WriteVersion`. You, as the designer of the class, do not need to do any manual modification in the Streamer. ROOT schema evolution mechanism is automatic and handled by the `StreamerInfo`.

Manual Schema Evolution

If you have written your own Streamer as described in the section "Streamers with Special Additions", you will have to manually add code for each version and manage the evolution of your class. When you add or remove data members, you must modify the Streamer by hand. ROOT assumes that you have increased the class version number in the `ClassDef` statement and introduced the relevant test in the read part of the Streamer. For example, if a new version of the Event class above includes a new member: `Int_t fNew` the `ClassDef` statement should be changed to `ClassDef (Event, 2)` and the following lines should be added to the read part of the Streamer:

```
if (R__v > 1) {
    R__b >> fNew;
} else {
    fNew = 0;           // set to some default value
}
```

If, in the same new version 2 you remove the member `fH`, you must add the following code to read the histogram object into some temporary object and delete it:

```
if (R__v) < 2 {
    TH1F *dummy = 0;
    R__b >> dummy;
    delete dummy;
}
```

Our experience with manual schema evolution shows that it is easy to make and mismatches between Streamer writers and readers are frequent and increase as the number of classes increase. We recommend you use `rootcint` generated Streamers whenever you can, and profit from the automatic schema evolution.

Building Class Definitions with the StreamerInfo

A ROOT file's `StreamerInfo` list contains the description of all versions of all classes in the file. When a file is opened the `StreamerInfo` is read into memory and it provides enough information to make the file browsable. The `TStreamerInfo` enables us to recreate a header file for the class in case the compiled class is not available. This is done with the `TFile::MakeProject` method. It creates a directory with the header files for the named classes and a `makefile` to compile a shared library with the class definitions.

Example: MakeProject

To explain the details, we use the example of the `ATLFast` project which is a fast simulation for the ATLAS experiment. The complete source for `ATLFast` can be downloaded at: <ftp://root.cern.ch/root/atlfast.tar.gz>. Once we compile and run `ATLFast` we get a ROOT file called `atlfast.root`, containing the `ATLFast` objects. When we open the file, we get a warning that the file contains classes that are not in the CINT dictionary. This is correct since we did not load the class definitions.

```
root[] TFile f("atlfast.root")
Warning in <TClass::TClass>: no dictionary for class TMCParticle is available
Warning in <TClass::TClass>: no dictionary for class ATLFMuon available
```

We can see the `StreamerInfo` for the classes:

```
root[] f.ShowStreamerInfo()
...
StreamerInfo for class: ATLFMuon, version=1
BASE  TObject      offset= 0 type=66 Basic ROOT object
BASE  TAtt3D       offset= 0 type= 0 3D attributes
Int_t m_KFcode     offset= 0 type= 3 Muon KF-code
Int_t m_MCParticle offset= 0 type= 3 Muon position in MCParticles list
Int_t m_KFmother   offset= 0 type= 3 Muon mother KF-code
Int_t m_UseFlag    offset= 0 type= 3 Muon energy usage flag
Int_t m_Isolated   offset= 0 type= 3 Muon isolation (1 for isolated)
Float_t m_Eta      offset= 0 type= 5 Eta coordinate
Float_t m_Phi      offset= 0 type= 5 Phi coordinate
Float_t m_PT       offset= 0 type= 5 Transverse energy
Int_t  m_Trigger   offset= 0 type= 3 Result of trigger...
```

However, when we try to use a specific class we get a warning because the class is not in the CINT dictionary. We can create a class using `gROOT->GetClass()` which makes a fake class from the `StreamerInfo`.

```
// Build a 'fake' class
root[] gROOT->GetClass ("ATLFMuon")
(const class TClass*)0x87e5c08
// The fake class has a StreamerInfo
root[] gROOT->GetClass ("ATLFMuon")->GetStreamerInfo ()->ls ()
StreamerInfo for class: ATLFMuon, version=1
BASE      TObject      offset= 0 type=66 Basic ROOT object
BASE      TAtt3D       offset= 0 type= 0 3D attributes
Int_t     m_KFcode     offset= 16 type= 3 Muon KF-code
Int_t     m_MCParticle offset= 20 type= 3 Muon position in MCParticles list
Int_t     m_KFmother   offset= 24 type= 3 Muon mother KF-code
Int_t     m_UseFlag    offset= 28 type= 3 Muon energy usage flag
Int_t     m_Isolated   offset= 32 type= 3 Muon isolation
Float_t   m_Eta        offset= 36 type= 5 Eta coordinate
Float_t   m_Phi        offset= 40 type= 5 Phi coordinate
Float_t   m_PT         offset= 44 type= 5 Transverse energy
Int_t     m_Trigger    offset= 48 type= 3 Result of trigger
i= 0, TObject      type= 66, offset= 0, len=1, method=0
i= 1, TAtt3D       type= 0, offset= 0, len=1, method=142684688
i= 2, m_KFcode     type= 23, offset= 16, len=5, method=0
i= 3, m_Eta        type= 25, offset= 36, len=3, method=0
i= 4, m_Trigger    type= 3, offset= 48, len=1, method=0
```

MakeProject has three parameters:

```
MakeProject(const char *dirname,const char *classes,Option_t *option)
```

The first is the directory name in which to place the generated header files. The second parameter is the name of the classes to include in the project. By default all classes are included. It recognizes the wild card character *, for example: "ATLF*" includes all classes beginning with ATLF. The third parameter is an option with the following values:

- "new" If the directory does not exist, it is created.
- "recreate" If the directory does not exist, it is creates as in "new", in addition if the directory does exist, all existing files are deleted before creating the new files.
- "update" The new classes are added to the existing directory and the existing classes are replaced with the new definition. If the directory does not exist, it creates it as in "new".
- "+": This option can be used in combination with the other three. It will create the necessary files to easily build a shared library containing the class definitions. Specifically it will:
 - Generate a script called MAKE that builds the shared library containing the definition of all classes in the directory.
 - Generate a LinkDef.h files to use with rootcint in MAKE.
 - Run rootcint to generate a <dirname>ProjectDict.cxx file
 - Compile the <dirname>ProjectDict.cxx with the current options in compiledata.h.
 - Build a shared library <dirname>.so.
- "++": This option can be used instead of the single "+". It does everything the single "+" does, and dynamically loads the shared library <dirname>.so.

This example makes a directory called MyProject that will contain all class definition from the atlfast.root file. The necessary makefile to build a shared library are also created, and since the '++' is appended, the shared library is also loaded.

```
root[] f.MakeProject("MyProject","*", "recreate++")
MakeProject has generated 0 classes in MyProject
MyProject/MAKE file has been generated
Shared lib MyProject/MyProject.so has been generated
Shared lib MyProject/MyProject.so has been dynamically linked
```

The contents of MyProject:

```
root[] .! ls MyProject
ATLFCluster.h   ATLFJet.h           ATLFMiscMaker.h   ATLFTrack.h   MAKE
TMCParticle.h  ATLFClusterMaker.h ATLFJetMaker.h    ATLFMuon.h
ATLFElectron.h ATLFMCMaker.h       ATLFMuonMaker.h   ATLFElectronMaker.h
ATLFMaker.h    ATLFPhoton.h        ATLFHistBrowser.h ATLFMisc.h
ATLFPhotonMaker.h ATLFTrackMaker.h ATLFTrigger.h     ATLFTriggerMaker.h
LinkDef.h      MyProject.so        MyProjectProjectDict.cxx
MyProjectProjectDict.h MyProjectProjectDict.o
```

Now you can load the shared library in any consecutive root session to use the atlfast classes.

```
root[] gSystem->Load("MyProject/MyProject")
root[] ATLFMuon muon
```

This is an example of a generated header file:

```
////////////////////////////////////
// This class has been generated by TFile::MakeProject
// (Thu Apr 5 10:18:37 2001 by ROOT version 3.00/06)
// from the TStreamerInfo in file atlfast.root
////////////////////////////////////
#ifndef ATLFMuon_h
#define ATLFMuon_h
#include "TObject.h"
#include "TAtt3D.h"
class ATLFMuon : public TObject , public TAtt3D {
public:
    Int_t      m_KFcode;           //Muon KF-code
    Int_t      m_MCParticle;       //Muon position in MCParticles list
    Int_t      m_KFmother;         //Muon mother KF-code
    Int_t      m_UseFlag;          //Muon energy usage flag
    Int_t      m_Isolated;         //Muon isolation (1 for isolated)
    Float_t    m_Eta;              //Eta coordinate
    Float_t    m_Phi;              //Phi coordinate
    Float_t    m_PT;              //Transverse energy
    Int_t      m_Trigger;          //Result of trigger
    ATLFMuon() {}
    virtual ~ATLFMuon() {}
    ClassDef(ATLFMuon,1) //
};
    ClassImp(ATLFMuon)
#endif
```

Migrating to ROOT 3

We will distinguish the following cases:

Case A: You have your own `Streamer` method in your class implementation file. This also means that you have specified `MyClass` in the `LinkDef.h` file.

- Keep `MyClass` - unchanged.
- Increment your class version id in `ClassDef` by 1, e.g. `ClassDef(MyClass, 2)`
- Change your `Streamer` function in the following way:
The old write block can be replaced by the new standard `Write`. Change the read block to use the new scheme for the new versions and the old code for the old versions.

```

void MyClass::Streamer(TBuffer &R__b)
{
    // Stream an object of class MyClass.

    if (R__b.IsReading()) {
        UInt_t R__s, R__c;
        Version_t R__v = R__b.ReadVersion(&R__s, &R__c);
        if (R__v > 1) {
            MyClass::Class()->ReadBuffer(R__b, this, R__v, R__s, R__c);
            return;
        }
        // process old versions before automatic schema evolution
        R__b >> xxxx;
        R__b >> .. etc
        R__b.CheckByteCount(R__s, R__c, MyClass::IsA());
        // end of old versions
    } else {
        MyClass::Class()->WriteBuffer(R__b, this);
    }
}

```

Case B: You use the automatic `Streamer` in the dictionary file.

- Move the old `Streamer` from the file generated by `rootcint` to your class implementation file, then modify the `Streamer` function as in Case A above.
- Increment your class version id in `ClassDef` by 1, i.e. `ClassDef(MyClass, 2)`
- Add option "-" in the pragma line of `LinkDef`.

Case C: You use the automatic `Streamer` in the dictionary file and you already use the option "+" in the `LinkDef` file. If the old automatic `Streamer` does not contain any statement using the function `WriteArray`, you have nothing to do, except running `rootcint` again to regenerate the new form of the `Streamer` function, otherwise proceed like for case B.

Compression and Performance

ROOT uses a compression algorithm based on the well-known `gzip` algorithm. It supports nine levels of compression. The default for ROOT is one. The compression level can be set with the method `TFile::SetCompressionLevel`. The experience with this algorithm shows that a compression level of 1.3 for raw data files and around two on most DST files is the optimum. The choice of one for the default is a compromise between the time it takes to read and write the object vs. the disk space savings.

To specify no compression, set the level to zero.

We recommend using compression when the time spent in I/O is small compared to the total processing time. If the I/O operation is increased by a factor of 5 it is still a small percentage of the total time and it may compress the data by a factor of 10. On the other hand if the time spend on I/O is large, compression may have a large impact on the program's performance.

The compression factor, i.e. the savings of disk space, varies with the type of data. A buffer with a same value array is compressed so that the value is only written once. For example a track has the mass of a pion which it is always the same, and the charge of the pion which is either positive or negative. For 1000 pions, the mass will be written only once, and the charge only twice (positive and negative).

When the data is sparse, i.e. when there are many zeros, the compression factor is also high.

Compression level	Bytes	Write Time (sec)	Read Time (sec.)
0	1,004,998	4.77	0.07
1	438,366	6.67	0.05
5	429,871	7.03	0.06
9	426,899	8.47	0.05

The time to uncompress an object is small compared to the compression time and is independent of the selected compression level. Note that the compression level may be changed at any time, but the new compression level will only apply to newly written objects. Consequently, a ROOT file may contain objects with different compression levels. This table shows four runs of the demo script that creates 15 histograms with different compression parameters. To make the numbers more significant, the macro was modified to create 1000 histograms. We have included two more examples to show the impact of compression on Trees in the next chapter.

Remotely Access to ROOT Files via a rootd

Reading and writing ROOT files over the net can be done by creating a `TNetFile` object instead of a `TFile` object. Since the `TNetFile` class inherits from the `TFile` class, it has exactly the same interface and behavior. The only difference is that it reads and writes to a remote `rootd` daemon.

TNetFile URL

`TNetFile` file names are in standard URL format with protocol "`root`". The following are valid `TNetFile` URL's:

```
root://hpsalo/files/aap.root
root://hpbrun.cern.ch/root/hsimple.root
root://pcna49a:5151/~na49/data/run821.root
root://pcna49d.cern.ch:5050//v1/data/run810.root
```

The only difference with the well-known http URL's is that the root of the remote file tree is the remote user's home directory. Therefore an absolute pathname requires a `//` after the host or port (as shown in the last example above). Further the expansion of the standard shell characters, like `~`, `$`, `..`, etc. is handled as expected. The default port on which the remote `rootd` listens is 1094 and this default port is assumed by `TNetFile` (actually by `TUrl` which is used by `TNetFile`). The port number has been allocated by the IANA and is reserved for ROOT.

Remote Authentication

Connecting to a `rootd` daemon requires a remote user id and password. `TNetFile` supports several ways for you to provide your login information:

- Setting it globally via the static `TNetFile` functions `TNetFile::SetUser()` and `TNetFile::SetPasswd()`
- Via the `~/.netrc` file (same format and file as used by `ftp`)
- Via command line prompt
- Setting the SPR password file via the option `-P FILE`, i.e. the next line will start the `rootd` daemon using the files `$HOME/.srootdpass2.conf` and `$HOME/.srootdpass2` for SPR authentication: **`rootd -P $HOME/.srootdpass2`**

A Simple Session

```
root[] TFile *f1 = TFile::Open("local/file.root", "update")
root[] TFile *f2 =
    TFile::Open("root://pcna49a.cern.ch/data/file.root", "new")
Name (pcna49a:rdm):
Password:
root[] TFile *f3 =
    TFile::Open("http://root.cern.ch/~rdm/hsimple.root")
root[] f3.ls()
TWebFile** http://root.cern.ch/~rdm/hsimple.root
TWebFile* http://root.cern.ch/~rdm/hsimple.root
KEY: TH1F hpx;1 This is the px distribution
KEY: TH2F hpypy;1 py vs px
KEY: TProfile hprof;1 Profile of pz versus px
KEY: TNtuple ntuple;1 Demo ntuple
root[] hpx.Draw()
```

The rootd Daemon

The `rootd` daemon works with the `TNetFile` class. It allows remote access to ROOT database files in read or read/write mode. The `rootd` daemon can be found in the directory `$ROOTSYS/bin`. It can be started either via `inetd` or by hand from the command line (no need to be super user). Its performance is comparable with NFS but while NFS requires all kind of system permissions to setup, `rootd` can be started by any user. The simplest way to start `rootd` is by starting it from the command line while being logged in to the remote machine. Once started `rootd` goes immediately in the background (does not need `&`) and you can log out from the remote node. The only required argument is the range of ports `-p port1-port2` that will be searched for the first available port on which your private `rootd` will listen. You can also specify `-p 0-N` for search relative to the service port specified in `/etc/services`. If a single port is specified as before via `rootd -p 1094`, then no search is made. Unless started by `inetd` (`rootd -i`), it prints information about the found port, something like: `ROOTD_PORT=5151, ROOTD_PID=14433` before spawning the daemon. This way the user knows what was used (`eval `rootd`` will set these as variables in Bourne-shells). Also, `rootd` shows an error message (as well as the `syslog` message it always sent) if there is any problem binding the port or forking the daemon.

Using `TNetFile` you can now read and write files on the remote machine.

In the example below, `rootd` runs on the remote node under user id `minuser` and searches for an available port into the range `1094÷1098`. It finds and listens to port `1094`. When creating a `TNetFile` object you have to specify the same port number `1094` and use `minuser` (and corresponding password) as login id. When `rootd` is started in this way, you can only login with the user id under which `rootd` was started on the remote machine.

```
hpsalo[] telnet fsgi02.fnal.gov
login: minuser
Password:
<fsgi02> rootd -p 1094-1098
ROOTD_PORT=1094
ROOTD_PID=14433
<fsgi02> exit
hpsalo[] root
root[] TFile *f = TFile::Open
    ("root://fsgi02.fnal.gov:1094/file.root", "new")
Name (fsgi02.fnal.gov:rdm): minuser
Password:
root[] f.ls()
```

However, you can make many connections since the original `rootd` will fork (spawn) a new `rootd` that will service the requests from the `TNetFile`. The original `rootd` keeps listening on the specified port for other connections. Each time a `TNetFile` makes a connection; it gets a new private `rootd` that will handle its requests. At the end of a ROOT session when all `TNetFiles` are closed only the original `rootd` will stay alive ready to service future `TNetFile(s)`.

Starting rootd via inetd

If you expect to often connect via `TNetFile` to a remote machine, it is more efficient to install `rootd` as a service of the `inetd` super daemon. In this way, it is not necessary for each user to run a private `rootd`. However, this requires a one-time modification of two system files (and super user privileges to do so). Add to `/etc/services` the line:

```
rootd 1094/tcp
```

To `/etc/inetd.conf` the line:

```
rootd stream tcp nowait root /usr/local/root/bin/rootd rootd -i
```

After these changes force `inetd` to reread its configuration file with:
"kill -HUP <pid inetd>".

It is not necessary to specify a port number in the URL given to `TNetFile` when the setup done this way. `TNetFile` assumes the default port to be 1094 as specified above in the `/etc/services` file.

Command Line Arguments for rootd

`rootd` supports the following arguments:

<code>-i</code>	says that <code>rootd</code> is started by <code>inetd</code>
<code>-p port#-port#</code>	specifies the range of ports to be searched
<code>-p 0-N</code>	the service ports range in <code>/etc/services</code>
<code>-d level</code>	level of debug info written to <code>syslogd</code>
	0 = no debug (default)
	1 = minimum
	2 = medium
	3 = maximum

Reading ROOT Files via Apache Web Server

By adding one ROOT specific module to your Apache web server, you can distribute ROOT files to any ROOT user. There is no longer a need to send your files via FTP and risking (out of date) histograms or other objects. Your latest up-to-date results are always accessible to all your colleagues.

To access ROOT files via a web server, create a `TWebFile` object instead of a `TFile` object with a standard URL as file name. For example:

```
root[] TWebFile f("http://root.cern.ch/~rdm/hsimple.root")
root[] f.ls()
TWebFile** http://root.cern.ch/~rdm/hsimple.root
TWebFile* http://root.cern.ch/~rdm/hsimple.root
KEY: TH1F hpx;1 This is the px distribution
KEY: TH2F hpxpy;1 py vs px
KEY: TProfile hprof;1 Profile of pz versus px
KEY: TTuple ntuple;1 Demo tuple
root[] hpx.Draw()
```

Since `TWebFile` inherits from `TFile` all `TFile` operations work as expected. However, due to the nature of a web server a `TWebFile` is a read-only file.

A **TWebFile** is ideally suited to read relatively small objects (like histograms or other data analysis results). Although possible, you don't want to analyze large **TTree**'s via a **TWebFile**.

Here follows a step-by-step recipe for making your Apache 1.1 or 1.2 web server ROOT aware:

1. Go to your Apache source directory and add the file ftp://root.cern.ch/root/mod_root.c or ftp://root.cern.ch/root/mod_root133.c when your Apache server is > 1.2 (rename the file `mod_root.c`).
2. Add to the end of the Configuration file the line:
`Module root_module mod_root.o`
3. Run the Configure script
4. Type `make`
5. Copy the new `httpd` to its expected place
6. Go to the `conf` directory and add at the end of the `srm.conf` file the line:
`AddHandler root-action root`
7. Restart the `httpd` server

Using the General `Open()` Function of `TFile`

To make life simple we provide a general function to open any type of file (except shared memory files of class **TMapFile**). This functionality is provided by the static **TFile::Open()** function:

```
TFile *TFile::Open(const Text_t *name, Option_t *option="",
                  const Text_t *title="", Int_t compress, Int_t netopt)
```

Depending on the `name` argument, the function returns a **TFile**, a **TNetFile** or a **TWebFile** object. In case a **TNetFile** URL specifies a local file, a **TFile** object will be returned (and of course no login information is needed). The arguments of the `Open()` function are the same as the ones for the **TFile** constructor.

Using `ReOpen()` method it is possible to reopen a file with a different access mode, like from `READ` to `UPDATE` or from `NEW`, `CREATE`, `RECREATE`, `UPDATE` to `READ`. Thus the mode argument can be either `"READ"` or `"UPDATE"`. The method returns:

- 0 in case the mode was successfully modified;
- 1 in case the mode did not change (it was already as requested or there were wrong input arguments);
- -1 in case of failure. In the last case the file cannot be used anymore.

12 Trees

Why Should You Use a Tree?

In the [Input/Output](#) chapter, we saw how objects can be saved in ROOT files. In case you want to store large quantities of same-class objects, ROOT has designed the **TTree** and **TNtuple** classes specifically for that purpose. The **TTree** class is optimized to reduce disk space and enhance access speed. A **TNtuple** is a **TTree** that is limited to only hold floating-point numbers; a **TTree** on the other hand can hold all kind of data, such as objects or arrays in addition to all the simple types.

When using a **TTree**, we fill its branch buffers with leaf data and the buffers are written to file when it is full. Branches, buffers, and leaves, are explained a little later in this chapter, but for now, it is important to realize that not each object is written individually, but rather collected and written a bunch at a time.

This is where the **TTree** takes advantage of compression and will produce a much smaller file than if the objects were written individually. Since the unit to be compressed is a buffer, and the **TTree** contains many same-class objects, the header of the objects can be compressed.

The **TTree** reduces the header of each object, but it still contains the class name. Using compression, the class name of each same-class object has a good chance of being compressed, since the compression algorithm recognizes the bit pattern representing the class name. Using a **TTree** and compression the header is reduced to about 4 bytes compared to the original 60 bytes. However, if compression is turned off, you will not see these large savings.

The **TTree** is also used to optimize the data access. A tree uses a hierarchy of branches, and each branch can be read independently from any other branch. Now, assume that P_x and P_y are data members of the event, and we would like to compute $P_x^2 + P_y^2$ for every event and histogram the result.

If we had saved the million events without a **TTree** we would have to:

- read each event in its entirety into memory
- extract the P_x and P_y from the event
- compute the sum of the squares
- fill a histogram

We would have to do that a million times! This is very time consuming, and we really do not need to read the entire event, every time. All we need are two little data members (P_x and P_y). On the other hand, if we use a tree with one branch containing P_x and another branch containing P_y , we can read all values of P_x and P_y by only reading the P_x and P_y branches. This makes the use of the **TTree** very attractive.

A Simple TTree

This script builds a **TTree** from an ASCII file containing statistics about the staff at CERN.

This script, `staff.C` and its input file `staff.dat` are in `$ROOTSYS/tutorials`.

```
{
// example of macro to read data from an ascii file and
// create a root file with an histogram and a TTree.
gROOT->Reset();

// the structure to hold the variables for the branch
struct staff_t {
    Int_t cat;
    Int_t division;
    Int_t flag;
    Int_t age;
    Int_t service;
    Int_t children;
    Int_t grade;
    Int_t step;
    Int_t nation;
    Int_t hrweek;
    Int_t cost;
};
staff_t staff;

// open the ASCII file
FILE *fp = fopen("staff.dat","r");
char line[81];
// create a new ROOT file
TFile *f = new TFile("staff.root","RECREATE");
// create a TTree
TTree *tree = new TTree("tree","staff data from ascii file");
// create one branch with all information from the stucture
tree->Branch("staff",&staff.cat,"cat/I:division:flag:age:service:
            children:grade:step:nation:hrweek:cost");
// fill the tree from the values in ASCII file
while (fgets(&line,80,fp)) {
    sscanf(&line[0],"%d%d%d%d",
        &staff.cat,&staff.division,&staff.flag,&staff.age);
    sscanf(&line[13],"%d%d%d%d",&staff.service,
        &staff.children, &staff.grade,&staff.step);
    sscanf(&line[24],"%d%d%d",&staff.nation,
        &staff.hrweek, &staff.cost);
    tree->Fill();
}
// check what the tree looks like
tree->Print();
fclose(fp);
f->Write();
}
```

The script declares a structured called `staff_t`, with several integers representing the relevant attribute of a staff member. It opens the ASCII file, creates a ROOT file and a **TTree**. Then it creates one branch with the **TTree**: `Branch` method. The first parameter of the `Branch` method is the branch name. The second parameter is the address from which the first leaf is to be read. In this example it is the address of the structure `staff`. Once the branch is defined, the script reads the data from the ASCII file into the `staff_t` structure and fills the `tree`.

The ASCII file is closed, and the ROOT file is written to disk saving the `tree`. Remember, trees and histograms are created in the current directory, which is the file in our example. Hence an `f->Write()` saves the `tree`.

Show an Entry with TTree::Show

An easy way to access one entry of a tree is the use the `TTree::Show` method. For example to look at the 10th entry in the `staff.root` tree:

```
root[] TFile f("staff.root")
root[] tree->Show(10)
=====> EVENT:10
  cat          = 361
  division     = 9
  flag         = 15
  age          = 51
  service      = 29
  children     = 0
  grade        = 7
  step         = 13
  nation       = 7
  hrweek       = 40
  cost         = 7599
```

Print the Tree Structure with TTree::Print

A helpful command to see the tree structure meaning the number of entries, the branches and the leaves, is `TTree::Print`.

```
root[] tree->Print()
*****
*Tree      :tree      : staff data from ascii file
*Entries   :3354      : Total = 134680 bytes  File  Size = 46302
*
*          Tree compression factor = 3.24
*****
*Br       0 :staff:cat/I:division:flag:age:service:children:grade:step:
*          nation:hrweek:cost
*Entries   :3354 : Total Size = 127856 bytes  File Size = 39478
*Baskets   : 4 : Basket Size = 32000 bytes  Compression= 3.24
```

Scan a Variable the Tree with TTree::Scan

The `TTree::Scan` method shows all values of the list of leaves separated by a colon.

```
root [11] tree->Scan("cost:age:children")
*****
*      Row      *      cost *      age *      children *
*****
*          0 *      11975 *      58 *          0 *
*          1 *      10228 *      63 *          0 *
*          2 *      10730 *      56 *          2 *
*          3 *      9311 *      61 *          0 *
*          4 *      9966 *      52 *          2 *
*          5 *      7599 *      60 *          0 *
*          6 *      9868 *      53 *          1 *
*          7 *      8012 *      60 *          1 *
*          ...
```

The Tree Viewer

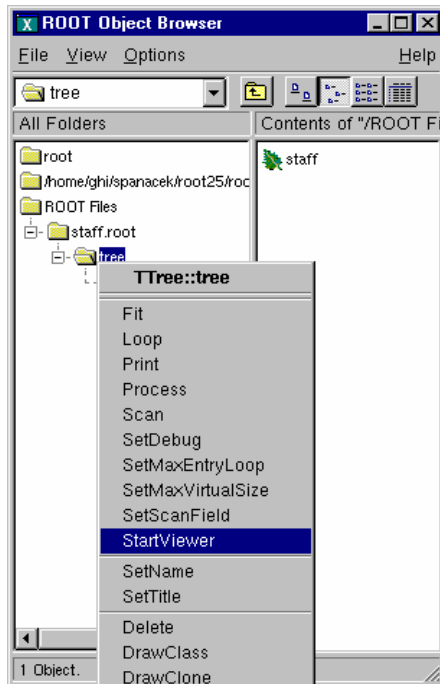

The tree viewer is a quick and easy way to examine a tree. To start the tree viewer, open a file and object browser. Right click on a `TTree` and select `StartViewer`. You can also start the tree viewer from the command line. First load the viewer library.

```
root [] TFile f("staff.root")
root [] tree->StartViewer()
```

If you want to start a tree viewer without a tree, you need to load the tree player library first:

```
root [] gSystem->Load("libTreePlayer.so")
root [] new TTreeView()
```

Below is what the tree viewer looks like for the example file `staff.root`. The left panel contains the list of trees and their branches; in this case there is only one tree. You can add more trees with the File-Open command to open the file containing the new tree, then use the context menu on the right panel, select `SetTreeName` and enter the name of the tree to add. On the right are the leaves

or variables in the tree. You can double click on any leaf to a histogram it.

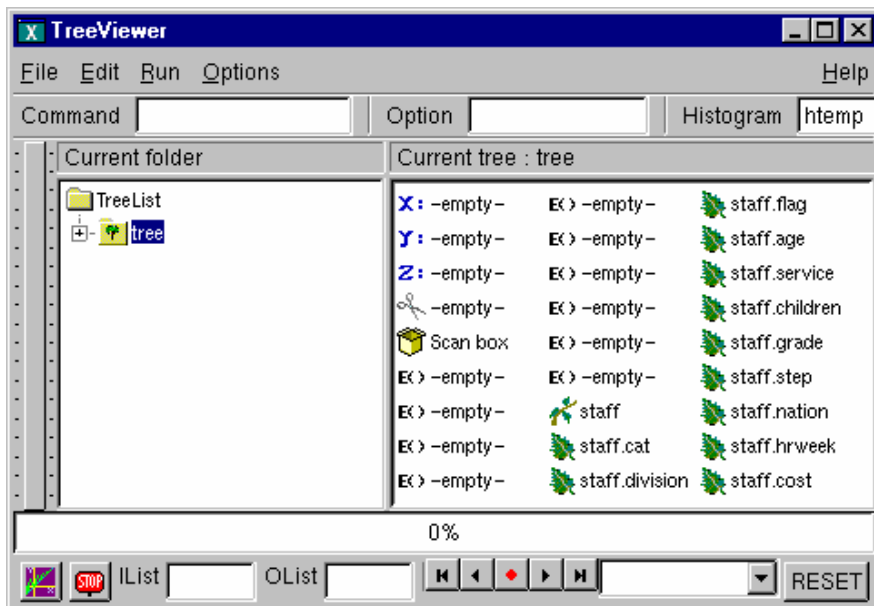

To draw more than one dimension you can drag and drop any leaf to the `X`, `Y`, `Z` "boxes". Then push the Draw button, which is marked with the purple icon on the bottom left.

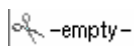

To add a cut/weight to the histogram, enter an expression in the "cut box". The cut box is the one with the scissor icon.

You can create a new expression by right clicking on any of the `E()` boxes. The expression can be dragged and dropped into any of the boxes (`X`, `Y`, `Z`, `Cut`, or `Scan`).

To scan one or more variables, drop them into the Scan box, then double click on the box. You can also redirect the result of the scan to a file by checking the Scan box on top.

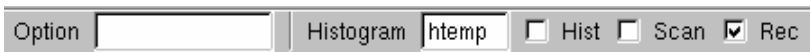

When the "Rec" box is checked, the `Draw` and `Scan` commands are recorded in the history file and echoed on the command line.

The "Histogram" text box contains the name of the resulting histogram. By default it is `htemp`. You can type any name, if the histogram does not exist it will create one.

The Option text box contains the list of Draw options (see [Draw Options](#) in the Histogram Chapter). You can select the options with the Options menu.

The Command box lets you enter any command that you could also enter on the command line.

The vertical slider on the far left side can be used to select the minimum and maximum of an event range. The actual start and end index are shown in on the bottom in the status window.

There is an extensive help utility accessible with the Help menu.

The `IList` and `OList` are to specify an input list of entry indices and a name for the output list respectively. Both need to be of type `TList` and contain integers of entry indices. These lists are described below in the paragraph "Creating an Event List".

Here are a couple of graphs. The first is a plot of the age distribution, the second a scatter plot of the cost vs. age. The second one was generated by dragging the age leaf into the Y-box and the cost leaf into the X-box, and pressing the Draw button. By default this will generate a scatter plot. Select a different option, for example "lego" to create a 2D histogram.

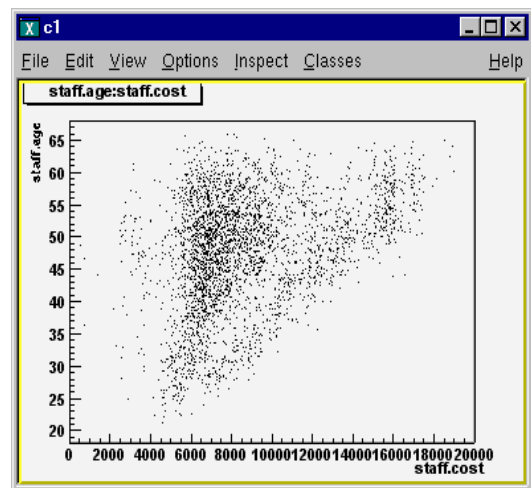
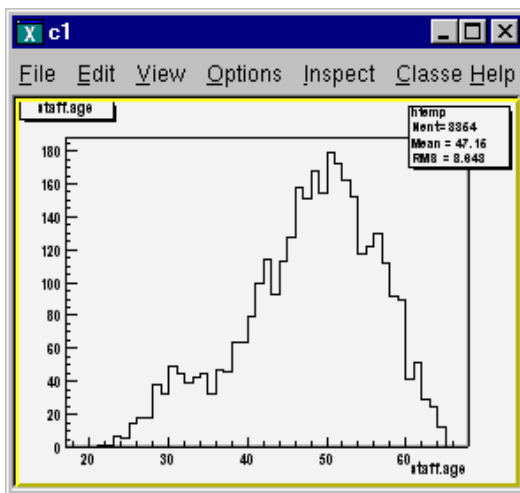

Creating and Saving Trees

This picture shows the `TTree` class:

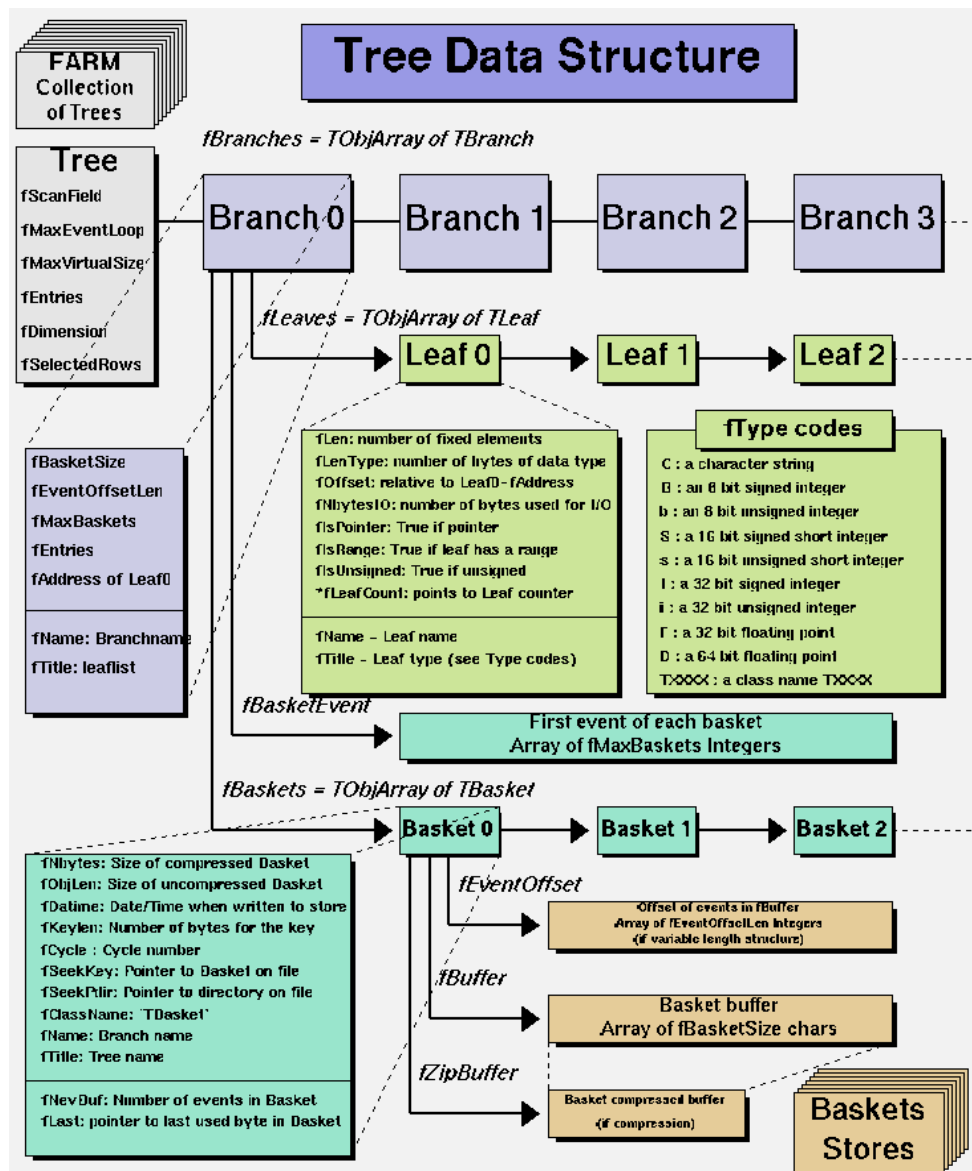

To create a `TTree` we use its constructor. Then we design our data layout and add the branches. A tree can be created by giving a name and title:

```
TTree t("MyTree", "Example Tree")
```

Creating a Tree from a Folder Hierarchy

An alternative way to create a tree and organize it, is to use folders. You can build a folder structure (see the chapter on [Folders and Tasks](#)), and create a tree with branches for each of the sub-folders:

```
TTree folder_tree("MyFolderTree", "/MyFolder")
```

The second argument `"/MyFolder"` is the top folder, and the `"` signals the `TTree` constructor that this is a folder not just the title. You fill the tree by placing the data into the folder structure and calling `TTree::Fill`. The reverse is also true; one can recreate the folder hierarchy from the tree with the `TTree::SetFolder` method.

Autosave

`Autosave` gives the option to save all branch buffers every `n` byte. We recommend using `Autosave` for large acquisitions. If the acquisition fails to complete, you can recover the file and all the contents since the last `Autosave`. To set the number of bytes between `Autosave` you can use the `TTree::SetAutosave()` method. You can also call `TTree::Autosave` in the acquisition loop every `n` entry.

Branches

The class for a branch is called `TBranch`. The organization of branches allows the designer to optimize the data for the anticipated use.

If two variables are independent, and the designer knows the variables will not be used together, she would place them on separate branches. If, however, the variables are related, such as the coordinates of a point, it is most efficient to create one branch with both coordinates on it. A variable on a `TBranch` is called a leaf (yes - `TLeaf`).

Another point to keep in mind when designing trees is the branches of the same `TTree` can be written to separate files. To add a `TBranch` to a `TTree` we call the `TTree::Branch()` method. Note that we DO NOT use the `TBranch` constructor.

The `TTree::Branch` method has several signatures. The branch type differs by what is stored in it. A branch can hold an entire object, a list of simple variables, contents of a folder, contents of a `TList`, or an array of objects. Let's see some examples. To follow along you will need the shared library `libEvent.so`. First, check if it is in `$ROOTSYS/test`. If it is, copy it to your own area. If it is not there, you have to build it.

Adding a Branch to Hold a List of Variables

As in the very first example (`staff.root`) the data we want to save is a list of simple variables, such as integers or floats. In this case, we use the following `TTree::Branch` signature:

```
tree->Branch("Ev_Branch", &event, "temp/F:ntrack/I:nseg:nvtex:flag/i ");
```



The first parameter is the branch name.

The second parameter is the address from which the first variable is to be read. In the code above, "event" is a structure with one float and three integers and one unsigned integer.

You should not assume that the compiler aligns the elements of a structure without gaps. To avoid alignment problems, you need to use structures with same length members. If your structure does not qualify, you need to create one branch for each element of the structure.

The leaf name is NOT used to pick the variable out of the structure, but is only used the name for the leaf. This means that the list of variables needs to be in a structure in the order described in the third parameter.

This third parameter is a string describing the leaf list. Each leaf has a name and a type separated by a "/" and it is separated from the next leaf by a ":".

```
<Variable>/<type>:<Variable>/<type>
```

The example on the next line has two leaves: a floating-point number called `temp` and an integer named `ntrack`.

```
"temp/F:ntrack/I:"
```

The type can be omitted and if no type is given, the same type as the previous variable is assumed. This leaf list has three integers called `ntrack`, `nseg`, and `nvtx`.

```
"ntrack/I:nseg:nvtx"
```

There is one more rule: when no type is given for the very first leaf, it becomes a `float` (F). This leaf list has three floats called `temp`, `mass`, and `px`.

```
"temp:mass:px"
```

The symbols used for the type are:

C:	a character string terminated by the 0 character
B:	an 8 bit signed integer
b:	an 8 bit unsigned integer
S:	a 16 bit signed integer
s:	a 16 bit unsigned integer
I:	a 32 bit signed integer
i:	a 32 bit unsigned integer
F:	a 32 bit floating point
D:	a 64 bit floating point

The type is used for a byte count to decide how much space to allocate. The variable written is simply the block of bytes starting at the starting address given in the second parameter. It may or may not match the leaf list depending on whether or not the programmer is being careful when choosing the leaf address, name, and type.

By default, a variable will be copied with the number of bytes specified in the type descriptor symbol. However, if the type consists of two characters, the number specifies the number of bytes to be used when copying the variable to the output buffer. The line below describes `ntrack` to be written as a 16-bit integer (rather than a 32-bit integer).

```
"ntrack/I2"
```

With this Branch method, you can also add a leaf that holds an entire array of variables. To add an array of floats use the `f[n]` notation when describing the leaf.

```
Float_t f[10];  
tree->Branch("fBranch",&f,"f[10]/F");
```

You can also add an array of variable length:

```
{  
  TFile *f = new TFile("peter.root","recreate");  
  Int_t nPhot;  
  Float_t E[500];  
  
  TTree* nEmcPhotons = new TTree("nEmcPhotons","EMC Photons");  
  nEmcPhotons->Branch("nPhot",&nPhot,"nPhot/I");  
  nEmcPhotons->Branch("E",E,"E[nPhot]/F");  
}
```

For an example see Example 2 below (`$ROOTSYS/tutorials/tree2.C`) and `staff.C` at the beginning of this chapter.

Adding a TBranch to Hold an Object

To write a branch to hold an event object, we need to load the definition of the `Event` class, which is in `$ROOTSYS/test/libEvent.so`. An object can be in a tree if its class definition includes the `ClassDef/ClassImp` macros. We expect to remove this restriction in the near future.

```
root[] .L libEvent.so
```

First, we need to open a file and create a tree.

```
root[] TFile *f = new TFile("AFile.root", "RECREATE")
root[] TTree *tree = new TTree("T", "A Root Tree")
```

We need to create a pointer to an `Event` object that will be used as a reference in the `TTree::Branch` method. Then we create a branch with the `TTree::Branch` method.

```
root[] Event *event = new Event()
root[] tree->Branch("EventBranch", "Event", &event, 32000, 99)
```

To add a branch to hold an object we use the signature above. The first parameter is the name of the branch. The second parameter is the name of the class of the object to be stored. The third parameter is the address of a pointer to the object to be stored.

Note that it is an address of a pointer to the object, not just a pointer to the object.

The fourth parameter is the buffer size and is by default 32000 bytes. It is the number of bytes of data for that branch to save to a buffer until it is saved to the file. The last parameter is the split-level, which is the topic of the next section. Static class members are not part of an object and thus not written with the object. You could store them separately by collecting these values in a special "status" object and write it to the file outside of the tree. If it makes sense to store them for each object, make them a regular data member.

Setting the Split-level

To split a branch means to create a sub-branch for each data member in the object. The split-level can be set to 0 to disable splitting or it can be set to a number between 1 and 99 indicating the depth of splitting.

If the split-level is set to zero, the whole object is written in its entirety to one branch. The `TTree` will look like the one on the right, with one branch and one leaf holding the entire event object.



A tree that is split



A tree that is not split

When the split level is 1, an object data member is assigned a branch. If the split level is 2, the data member objects will be split also, and a split level of 3 its data members objects, will be split. As the split level increases so does the splitting depth. The ROOT default for the split level is 99. This means the object will be split to the maximum.

Memory Considerations when Splitting a Branch

Splitting a branch can quickly generate many branches. Each branch has its own buffer in memory. In case of many branches (say more than 100), you should adjust the buffer size accordingly. A recommended buffer size is 32000 bytes if you have less than 50 branches. Around 16000 bytes if you have less than 100 branches and 4000 bytes if you have more than 500 branches. These numbers are recommended for computers with memory size ranging from 32MB to 256MB. If you have more memory, you should specify larger buffer sizes. However, in this case, do not forget that your file might be used on another machine with a smaller memory configuration.

Performance Considerations when Splitting a Branch

A split branch is faster to read, but slightly slower to write. The reading is quicker because variables of the same type are stored consecutively and the type does not have to be read each time. It is slower to write because of the large number of buffers as described above. See Performance Benchmarks for performance impact of split and non-split mode.

Rules for Splitting

When splitting a branch, variables of different types are handled differently. Here are the rules that apply when splitting a branch.

- If a data member is a basic type, it becomes one branch of class **TBranchElement**.
- A data member can be an array of basic types. In this case, one single branch is created for the array.
- A data member can be a pointer to an array of basic types. The length can vary, and must be specified in the comment field of the data member in the class definition. (see [Input/Output](#) chapter).
- Pointer data member are not split, except for pointers to a **TClonesArray**. The **TClonesArray** (pointed to) is split if the split level is greater than two. When the split level is one, the **TClonesArray** is not split.
- If a data member is a pointer to an object, a special branch is created. The branch will be filled by calling the class `Streamer` function to serialize the object into the branch buffer.
- If a data member is an object, the data members of this object are split into branches according to the split level (i.e. split level > 2).
- Base classes are split when the object is split.
- Abstract base classes are never split
- Most STL containers are supported except for some extreme cases. These examples are not supported:

```
// STL vector of vectors of TAxis*
vector<vector<TAxis *> > fVectAxis;

// STL map of string/vector
map<string,vector<int> > fMapString;

// STL deque of pair
deque<pair<float,float> > fDequePair;
```

- C-structure data members are not supported in split mode.
- An object that is not split may be slow to browse.
- An STL container that is not split will not be accessible in the browser.

Exempt a Data Member from Splitting

If you are creating a branch with an object and in general you want the data members to be split, but you want to exempt a data member from the split. You can specify this in the comment field of the data member:

```
class Event : public TObject {
private:
    EventHeader    fEvtHdr;        /// Don't split the header
```

Adding a Branch to Hold a TClonesArray

ROOT has two classes to manage arrays of objects. The `TObjArray` can manage objects of different classes, and the `TClonesArray` that specializes in managing objects of the same class (hence the name Clones Array). `TClonesArray` takes advantage of the constant size of each element when adding the elements to the array. Instead of allocating memory for each new object as it is added, it reuses the memory. Here is an example of the time a `TClonesArray` can save over a `TObjArray`.

We have 100,000 events, and each has 10,000 tracks, which gives 1,000,000,000 tracks. If we use a `TObjArray` for the tracks, we implicitly make a call to `new` and a corresponding call to `delete` for each track. The time it takes to make a pair of `new/delete` calls is about 7 μs (10^{-6}). If we multiply the number of tracks by 7 μs , ($1,000,000,000 * 7 * 10^{-6}$) we calculate that the time allocating and freeing memory is about 2 hours. This is the chunk of time saved when a `TClonesArray` is used rather than a `TObjArray`. If you don't want to wait 2 hours for your tracks (or equivalent objects), be sure to use a `TClonesArray` for same-class objects arrays.

Branches with `TClonesArrays` use the same method (`TTree::Branch`) as any other object described above. If `splitting` is specified the objects in the `TClonesArray` are split, not the `TClonesArray` itself.

Identical Branch Names

When a top-level object (say `event`), has two data members of the same class the sub branches end up with identical names. To distinguish the sub branch we must associate them with the master branch by including a "." (a dot) at the end of the master branch name. This will force the name of the sub branch to be `master.sub` branch instead of simply `sub` branch. For example, a tree has two branches `Trigger` and `MuonTrigger`, each containing an object of the same class (`Trigger`). To uniquely identify the sub branches we add the dot:

```
tree->Branch("Trigger.", "Trigger", &b1, 8000, 1);
tree->Branch("MuonTrigger.", "Trigger", &b2, 8000, 1);
```

If `Trigger` has three members, `T1`, `T2`, `T3`, the two instructions above will generate sub branches called: `Trigger.T1`, `Trigger.T2`, `Trigger.T3`, `MuonTrigger.T1`, `MuonTrigger.T2`, `MuonTrigger.T3`.

Adding a Branch with a Folder

Use the syntax below to add a branch from a folder:

```
tree->Branch("/aFolder");
```

This method creates one branch for each element in the folder. The method returns the total number of branches created.

Adding a Branch with a Collection

This `Branch` method creates one branch for each element in the collection.

```
tree->Branch(*aCollection, 8000, 99);
// Int_t TTree::Branch(TCollection *list, Int_t bufsize,
// Int_t splitlevel, const char *name)
```

The method returns the total number of branches created. Each entry in the collection becomes a top level branch if the corresponding class is not a collection. If it is a collection, the entry in the collection becomes in turn top level branches, etc. The split level is decreased by 1 every time a new collection is found.

For example if list is a **TObjArray***

- If `splitlevel = 1`, one top level branch is created for each element of the **TObjArray**.
- If `splitlevel = 2`, one top level branch is created for each array element. If, in turn, one of the array elements is a **TCollection**, one top level branch will be created for each element of this collection.

In case a collection element is a **TClonesArray**, the special Tree constructor for **TClonesArray** is called. The collection itself cannot be a **TClonesArray**.

If `name` is given, all branch names will be prefixed with `name_`.

IMPORTANT NOTE1: This function should not be called if `splitlevel < 1`.

IMPORTANT NOTE2: The branches created by this function will have names corresponding to the collection or object names. It is important to give names to collections to avoid misleading branch names or identical branch names. By default collections have a name equal to the corresponding class name, e.g. the default name of **TList** is "TList".

Examples for Writing and Reading Trees

The following sections are examples of writing and reading trees increasing in complexity from a simple tree with a few variables to a tree containing folders and complex Event objects.

Each example has a named script in the `$ROOTSYS/tutorials` directory. They are called `tree1.C` to `tree4.C`. The examples are:

- `tree1.C`: A tree with several simple (integers and floating point) variables.
- `tree2.C`: A tree built from a C structure (`struct`). This example uses the `Geant3 C` wrapper as an example of a FORTRAN common block ported to C with a C structure.
- `tree3.C`: In this example we will show how to extend a tree with a branch from another tree with the Friends feature. These trees have branches with variable length arrays. Each entry has a variable number of tracks, and each track has several variables.
- `tree4.C`: A tree with a class (`Event`). The class `Event` is defined in `$ROOTSYS/test`. In this example we first encounter the impact of splitting a branch.

Each script contains the main function, with the same name as the file (i.e. `tree1`), the function to write - `tree1w`, and the function to read - `tree1r`. If the script is not run in batch mode, it displays the tree in the browser and tree viewer. To study the example scripts, you can either execute the main script, or load the script and execute a specific function. For example:

```
// execute the function that writes, reads, shows the tree
root[] .x tree1.C
// use ACLiC to build shared library, check syntax, execute
root[] .x tree1.C++
// Load the script and select a function to execute
root[] .L tree1.C
root[] tree1w()
root[] tree1r()
```

Example 1: A Tree with Simple Variables

This example shows how to write, view, and read a tree with several simple (integers and floating point) variables.

Writing the Tree

Below is the function that writes the tree (`tree1w`). First, the variables are defined (`px`, `py`, `pz`, `random` and `ev`). Then we add a branch for each of the variables to the tree, by calling the `TTree::Branch` method for each variable.

```
void tree1w()
{
    //create a Tree file tree1.root
    //create the file, the Tree and a few branches
    TFile f("tree1.root","recreate");
    TTree t1("t1","a simple Tree with simple variables");
    Float_t px, py, pz;
    Double_t random;
    Int_t ev;
    t1.Branch("px",&px,"px/F");
    t1.Branch("py",&py,"py/F");
    t1.Branch("pz",&pz,"pz/F");
    t1.Branch("ev",&ev,"ev/I");

    //fill the tree
    for (Int_t i=0; i<10000; i++) {
        gRandom->Rannor(px,py);
        pz = px*px + py*py;
        random = gRandom->Rndm();
        ev = i;
        t1.Fill();
    }

    //save the Tree heade; the file will be automatically closed
    //when going out of the function scope
    t1.Write();
}
```

Creating Branches with A single Variable

This is the signature of `TTree::Branch` to create a branch with a list of variables:

```
TBranch* TTree::Branch(const char* name,void* address,
                      const char* leaflist,Int_t bufsize = 32000)
```

The first parameter is the branch name. The second parameter is the address from which to read the value. The third parameter is the leaf list with the name and type of each leaf.

In this example each branch has only one leaf. In the box below, the branch is named `px` and has one floating point type leaf also called `px`.

```
t1.Branch("px",&px,"px/F");
```

Filling the Tree

First we find some random values for the variables. We assign `px` and `py` a Gaussian with mean = 0 and sigma = 1 by calling `gRandom->Rannor(px, py)`, and calculate `pz`. Then we call the `TTree::Fill` method. The call `t1.Fill()` fills all branches in the tree because we have already organized the tree into branches and told each branch where to get the value from. After this script is executed we have a ROOT file called `tree1.root` with a tree called `t1`.

Viewing the Tree

This is the `tree1.root` file and its tree in the browser.

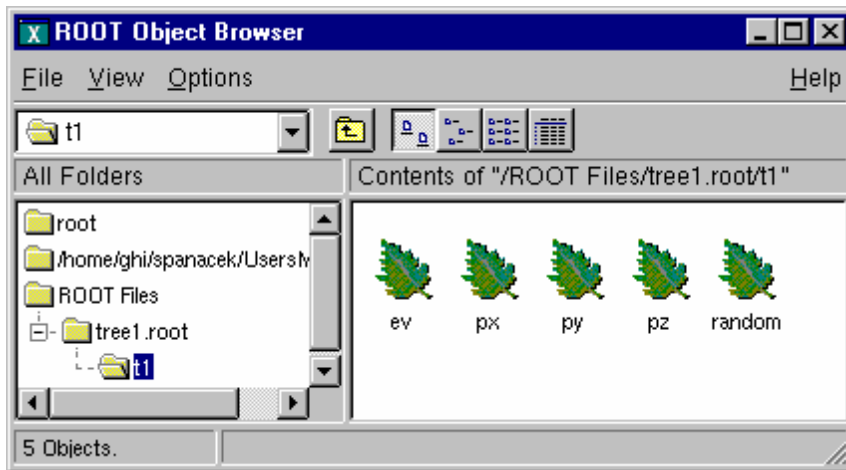

In the right panel are the branches: `ev`, `px`, `py`, `pz`, and `random`. Note that these are shown as leaves because they are "end" branches with only one leaf.

To histogram a leaf we can simply double click on it in the browser:

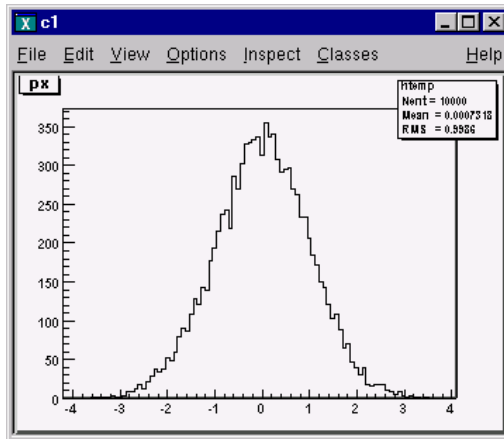

This is how the tree `t1` looks in the Tree Viewer. Here we can add a cut and add other operations for histogramming the leaves (see the section on Tree Viewer). For example, we can plot a two dimensional histogram.

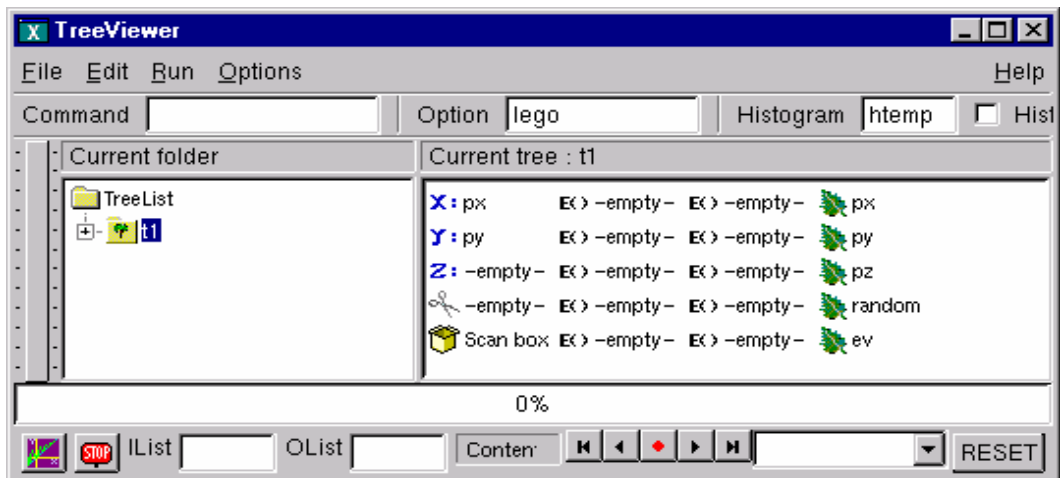

Reading the Tree

The `tree1r` function shows how to read the tree and access each entry and each leaf. We first define the variables to hold the read values.

```
Float_t px, py, pz;
```

Then we tell the tree to populate these variables when reading an entry. We do this with the `TTree::SetBranchAddresses` method. The first parameter is the branch name, and the second is the address of the variable where the branch data is to be placed.

In this example the branch name is `px`. This name was given when the tree was written (see `tree1w`). The second parameter is the address of the variable `px`.

```
t1->SetBranchAddresses("px", &px);
```

GetEntry

Once the branches have been given the address, a specific entry can be read into the variables with the method `TTree::GetEntry(n)`. It reads all the branches for entry (`n`) and populates the given address accordingly.

By default, `GetEntry()` reuses the space allocated by the previous object for each branch. You can force the previous object to be automatically deleted if you call `mybranch.SetAutoDelete(kTRUE)` (default is `kFALSE`).

Example:

Consider the example in `$ROOTSYS/test/Event.h`. The top level branch in the tree `T` is declared with:

```
Event *event = 0;
//event must be null or point to a valid object
//it must be initialized
T.SetBranchAddress("event", &event);
```

When reading the Tree, one can choose one of these 3 options:

Option 1:

```
for (Int_t i = 0; i<nentries; i++) {
  T.GetEntry(i);
  //the object event has been filled at this point
}
```

This is the default and recommended way to create an object of the class `Event`. It will be pointed by `event`.

At the following entries, `event` will be overwritten by the new data. All internal members that are `TObject*` are automatically deleted. It is important that these members be in a valid state when `GetEntry` is called. Pointers must be correctly initialized.

However these internal members will not be deleted if the characters `"->"` are specified as the first characters in the comment field of the data member declaration.

The pointer member is read via `pointer->Streamer(buf)` if `"->"` is specified. In this case, it is assumed that the pointer is never null (see pointer `TClonesArray *fTracks` in the `$ROOTSYS/test/Event` example). If `"->"` is not specified, the pointer member is read via `buf >> pointer`. In this case the pointer may be null. Note that the option with `"->"` is faster to read or write and it also consumes less space in the file.

Option 2:

The option `AutoDelete` is set:

```
TBranch *branch = T.GetBranch("event");
branch->SetAddress(&event);
branch->SetAutoDelete(kTRUE);
for (Int_t i=0; i<nentries; i++) {
    T.GetEntry(i);    // the object event has been filled at this point
}
```

In this case, at any iteration, the object `event` is deleted by `GetEntry` and a new instance of `Event` is created and filled.

Option 3:

Same as option 1, but you delete yourself the event:

```
for (Int_t i=0; i<nentries; i++) {
    delete event;
    event = 0;    EXTREMELY IMPORTANT
    T.GetEntry(i);
    the object event has been filled at this point
}
```

It is strongly recommended to use the default option 1. It has the additional advantage that functions like `TTree::Draw` (internally calling `TTree::GetEntry`) will be functional even when the classes in the file are not available. Reading selected branches is quicker than reading an entire entry. If you are interested in only one branch, you can use the `TBranch::GetEntry` method and only that branch is read. Here is the script `tree1r`:

```
void tree1r()
{
    //read the Tree generated by tree1w and fill two histograms
    //note that we use "new" to create the TFile and TTree objects,
    //to keep them alive after leaving this function.
    TFile *f = new TFile("tree1.root");
    TTree *t1 = (TTree*)f->Get("t1");
    Float_t px, py, pz;
    Double_t random;
    Int_t ev;
    t1->SetBranchAddresses("px", &px);
    t1->SetBranchAddresses("py", &py);
    t1->SetBranchAddresses("pz", &pz);
    t1->SetBranchAddresses("random", &random);
    t1->SetBranchAddresses("ev", &ev);
    //create two histograms
    TH1F *hpx = new TH1F("hpx", "px distribution", 100, -3, 3);
    TH2F *hpxpy = new TH2F("hpxpy", "py vs px", 30, -3, 3, 30, -3, 3);
    //read all entries and fill the histograms
    Int_t nentries = (Int_t)t1->GetEntries();
    for (Int_t i=0; i<nentries; i++) {
        t1->GetEntry(i);
        hpx->Fill(px);
        hpxpy->Fill(px, py);
    }
    //We do not close the file. We want to keep the generated histograms
    //we open a browser and the TreeViewer
    if (gROOT->IsBatch()) return;
    new TBrowser ();
    t1->StartViewer();
    //In the browser, click on "ROOT Files", then on "tree1.root"
    //You can click on the histogram icons in the right panel to draw
    //them in the TreeViewer, follow the instructions in the Help.
}
```

Example 2: A Tree with a C Structure

The executable script for this example is `$ROOTSYS/tutorials/tree2.C`. In this example we show:

- how to build branches from a C structure
- how to make a branch with a fixed length array
- how to make a branch with a variable length array
- how to read selective branches
- how to fill a histogram from a branch
- how to use `TTree::Draw` to show a 3D plot

A C structure (`struct`) is used to build a ROOT tree. In general we discourage the use of C structures, we recommend using a class instead. However, we do support them for legacy applications written in C or FORTRAN.

The example `struct` holds simple variables and arrays. It maps to a Geant3 common block `/gctrak/`. This is the definition of the common block/structure:

```
const Int_t MAXMEC = 30;
// PARAMETER (MAXMEC=30)
// COMMON/GCTRAK/VECT(7),GETOT,GEKIN,VOUT(7)
//   + ,NMEC,LMEC(MAXMEC)
//   + ,NAMEC(MAXMEC),NSTEP
//   + ,PID,DESTSTEP,DESTSEL,SAFETY,SLENG
//   + ,STEP,SNEXT,SFIELD,TOFG,GEKRAT,UPWGHT

typedef struct {
  Float_t vect[7];
  Float_t getot;
  Float_t gekin;
  Float_t vout[7];
  Int_t nmec;
  Int_t lmec[MAXMEC];
  Int_t namec[MAXMEC];
  Int_t nstep;
  Int_t pid;
  Float_t destep;
  Float_t destel;
  Float_t safety;
  Float_t sleng;
  Float_t step;
  Float_t snext;
  Float_t sfield;
  Float_t tofg;
  Float_t gekrat;
  Float_t upwght;
} Gctrak_t;
```

When using Geant3, the common block is filled by Geant3 routines at each step and only the `TTree::Fill` method needs to be called. In this example we emulate the Geant3 step routine with the `helixStep` function. We also emulate the filling of the particle values. The calls to the `Branch` methods are the same as if Geant3 were used.

```

void helixStep(Float_t step, Float_t *vect, Float_t *vout)
{
    // extrapolate track in constant field
    Float_t field = 20;           // field in kilogauss
    enum Evect {kX,kY,kZ,kPX,kPY,kPZ,kPP};
    vout[kPP] = vect[kPP];
    Float_t h4      = field*2.99792e-4;
    Float_t rho     = -h4/vect[kPP];
    Float_t tet     = rho*step;
    Float_t tsint  = tet*tet/6;
    Float_t sintt  = 1 - tsint;
    Float_t sint   = tet*sintt;
    Float_t coslt  = tet/2;
    Float_t f1     = step*sintt;
    Float_t f2     = step*coslt;
    Float_t f3     = step*tsint*vect[kPZ];
    Float_t f4     = -tet*coslt;
    Float_t f5     = sint;
    Float_t f6     = tet*coslt*vect[kPZ];
    vout[kX] = vect[kX] + (f1*vect[kPX] - f2*vect[kPY]);
    vout[kY] = vect[kY] + (f1*vect[kPY] + f2*vect[kPX]);
    vout[kZ] = vect[kZ] + (f1*vect[kPZ] + f3);
    vout[kPX] = vect[kPX] + (f4*vect[kPX] - f5*vect[kPY]);
    vout[kPY] = vect[kPY] + (f4*vect[kPY] + f5*vect[kPX]);
    vout[kPZ] = vect[kPZ] + (f4*vect[kPZ] + f6);
}

```

Writing the Tree

```

void tree2w() // write tree2 example
{
    //create a Tree file tree2.root
    TFile f("tree2.root","recreate");

    //create the file, the Tree
    TTree t2("t2","a Tree with data from a fake Geant3");

    // declare a variable of the C structure type
    Gctrak_t gstep;

    // add the branches for a subset of gstep
    t2.Branch("vect",gstep.vect,"vect[7]/F");
    t2.Branch("getot",&gstep.getot,"getot/F");
    t2.Branch("gekin",&gstep.gekin,"gekin/F");
    t2.Branch("nmec",&gstep.nmec,"nmec/I");
    t2.Branch("lmec",gstep.lmec,"lmec[nmec]/I");
    t2.Branch("destep",&gstep.destep,"destep/F");
    t2.Branch("pid",&gstep.pid,"pid/I");

    //Initialize particle parameters at first point
    Float_t px,py,pz,p,charge=0;
    Float_t vout[7];
    Float_t mass = 0.137;
    Bool_t newParticle = kTRUE;
    gstep.step = 0.1;
    gstep.destep = 0;
    gstep.nmec = 0;
    gstep.pid = 0;
}
//continued...

```

```

//transport particles
for (Int_t i=0; i<10000; i++) {
  //generate a new particle if necessary (Geant3 emulation)
  if (newParticle) {
    px = gRandom->Gaus(0, .02);
    py = gRandom->Gaus(0, .02);
    pz = gRandom->Gaus(0, .02);
    p = TMath::Sqrt(px*px+py*py+pz*pz);
    charge = 1;
    if (gRandom->Rndm() < 0.5) charge = -1;
    gstep.pid += 1;
    gstep.vect[0] = 0;
    gstep.vect[1] = 0;
    gstep.vect[2] = 0;
    gstep.vect[3] = px/p;
    gstep.vect[4] = py/p;
    gstep.vect[5] = pz/p;
    gstep.vect[6] = p*charge;
    gstep.getot = TMath::Sqrt(p*p + mass*mass);
    gstep.gekin = gstep.getot - mass;
    newParticle = kFALSE;
  }
  // fill the Tree with current step parameters
  t2.Fill();

  //transport particle in magnetic field (Geant3 emulation)
  helixStep(gstep.step, gstep.vect, vout); //make one step

  //apply energy loss
  gstep.destep = gstep.step*gRandom->Gaus(0.0002,0.00001);
  gstep.gekin -= gstep.destep;
  gstep.getot = gstep.gekin + mass;
  gstep.vect[6]= charge*TMath::Sqrt(gstep.getot*gstep.getot - mass*mass);
  gstep.vect[0] = vout[0];
  gstep.vect[1] = vout[1];
  gstep.vect[2] = vout[2];
  gstep.vect[3] = vout[3];
  gstep.vect[4] = vout[4];
  gstep.vect[5] = vout[5];
  gstep.nmec = (Int_t) (5*gRandom->Rndm());
  for (Int_t l=0; l<gstep.nmec; l++) gstep.lmec[l] = 1;
  if (gstep.gekin < 0.001) newParticle = kTRUE;
  if (TMath::Abs(gstep.vect[2]) > 30)
    newParticle = kTRUE;
}
//save the Tree header. The file will be automatically
// closed when going out of the function scope
t2.Write();
}

```

Adding a Branch with a Fixed Length Array

At first, we create a tree and create branches for a subset of variables in the C structure `Gctrak_t`. Then we add several types of branches.

The first branch reads seven floating point values beginning at the address of `'gstep.vect'`. You do not need to specify `&gstep.vect`, because in C and C++ the array variable holds the address of the first element.

```

t2.Branch("vect", gstep.vect, "vect[7]/F");
t2.Branch("getot", &gstep.getot, "getot/F");
t2.Branch("gekin", &gstep.gekin, "gekin/F");

```

Adding a Branch with a Variable Length Array

The next two branches are dependent on each other. The first holds the length of the variable length array and the second holds the variable length array. The `lmec` branch reads `nmec` number of integers beginning at the address `gstep.destep`.

```
t2.Branch("nmec",&gstep.nmec,"nmec/I");
t2.Branch("lmec",gstep.lmec,"lmec[nmec]/I");
```

The variable `nmec` is a random number and is reset for each entry.

```
gstep.nmec = (Int_t)(5*gRandom->Rndm());
```

Filling the Tree

In this emulation of Geant3, we generate and transport particles in a magnetic field and store the particle parameters at each tracking step in a ROOT tree.

Analysis

In this analysis we do not read the entire entry, we only read one branch. First we set the address for the branch to the file `dstep`, and then we use the `TBranch::GetEntry` method.

Then we fill a histogram with the `dstep` branch entries, draw it and fit it with a Gaussian.

In addition we draw the particle's path using the three values in the vector. Here we use the `TTree::Draw` method. It automatically creates a histogram and plots the 3 expressions (see Using Trees in Analysis).

```
void tree2r()
{
    // read the Tree generated by tree2w and fill one histogram
    // we are only interested by the destep branch

    // note that we use "new" to create the TFile and TTree objects because we want
    // to keep these objects alive when we leave this function

    TFile *f = new TFile("tree2.root");
    TTree *t2 = (TTree*)f->Get("t2");
    static Float_t destep;
    TBranch *b_destep = t2->GetBranch("destep");
    b_destep->SetAddress(&destep);

    //create one histogram
    TH1F *hdestep = new TH1F("hdestep","destep in Mev",100,1e-5,3e-5);

    //read only the destep branch for all entries
    Int_t nentries = (Int_t)t2->GetEntries();
    for (Int_t i=0;i<nentries;i++) {
        b_destep->GetEntry(i);

        // fill the histogram with the destep entry
        hdestep->Fill(destep);
    }
}
```

//continued...

```

// we do not close the file; we want to keep the generated histograms;
// we fill a 3-d scatter plot with the particle step coordinates

TCanvas *c1 = new TCanvas("c1","c1",600,800);
c1->SetFillColor(42);
c1->Divide(1,2);

c1->cd(1);
hdestep->SetFillColor(45);
hdestep->Fit("gaus");

c1->cd(2);
gPad->SetFillColor(37);
t2->SetMarkerColor(kRed);
t2->Draw("vect[0]:vect[1]:vect[2]");
if (gROOT->IsBatch()) return;

// invoke the x3d viewer
gPad->x3d();
}

```

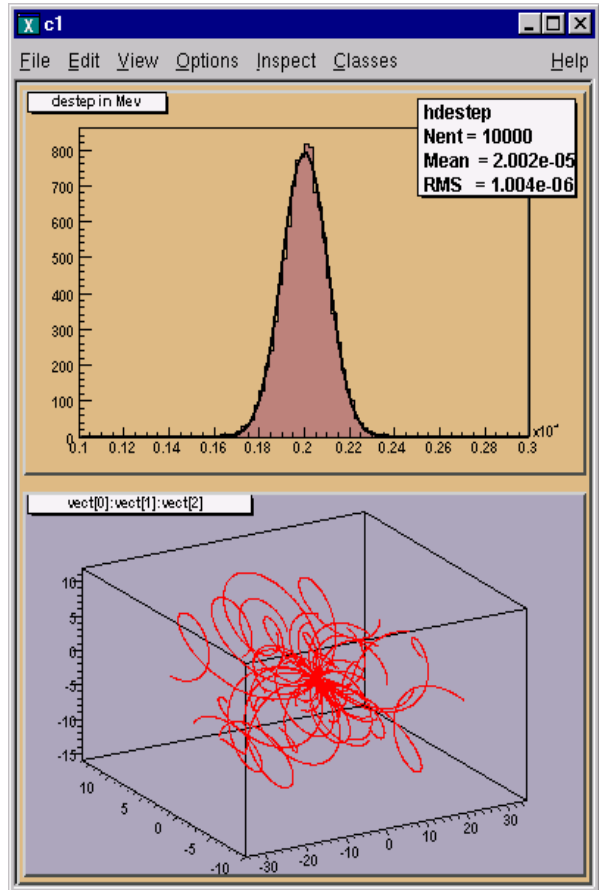
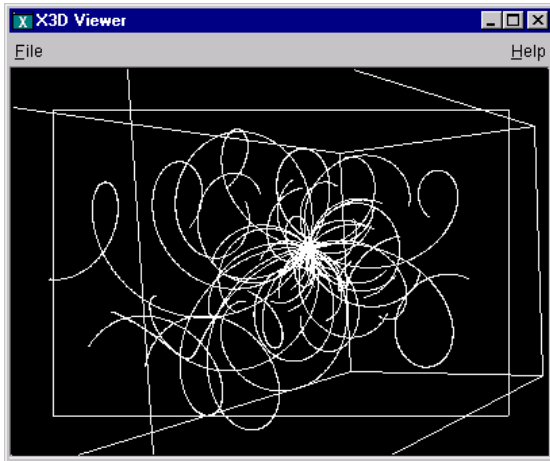

Example 3: Adding Friends to Trees

In this example we will show how to extend a tree with a branch from another tree with the Friends feature.

Adding a Branch to an Existing Tree

You may want to add a branch to an existing tree. For example, if one variable in the tree was computed with a certain algorithm, you may want to try another algorithm and compare the results. One solution is to add a new branch, fill it, and save the tree. The code below adds a simple branch to an existing tree. Note the `kOverwrite` option in the `Write` method, it overwrites the existing tree. If it is not specified, two copies of the tree headers are saved.

```
void tree3AddBranch()
{
    TFile f("tree3.root","update");

    Float_t new_v;
    TTree *t3 = (TTree*)f->Get("t3");
    TBranch *newBranch = t3->Branch("new_v",&new_v,"new_v/F");
    //read the number of entries in the t3
    Int_t nentries = (Int_t)t3->GetEntries();
    for (Int_t i = 0; i < nentries; i++){
        new_v= gRandom->Gaus(0,1);
        newBranch->Fill();
    }
    // save only the new version of the tree
    t3->Write("",TObject::kOverwrite);
}
```

Adding a branch is often not possible because the tree is in a read-only file and you do not have permission to save the modified tree with the new branch. Even if you do have the permission, you risk losing the original tree with an unsuccessful attempt to save the modification. Since trees are usually large, adding a branch could extend it over the 2GB limit. In this case, the attempt to write the tree fails, and the original data is may also be corrupted. In addition, adding a branch to a tree enlarges the tree and increases the amount of memory needed to read an entry, and therefore decreases the performance. For these reasons, ROOT offers the concept of friends for trees (and chains). We encourage you to use `TTree::AddFriend` rather than adding a branch manually.

TTree::AddFriend

A tree keeps a list of friends. In the context of a tree (or a chain), friendship means unrestricted access to the friends data. In this way it is much like adding another branch to the tree without taking the risk of damaging it. To add a friend to the list, you can use the `TTree::AddFriend` method. The `TTree(tree)` below has two friends (`ft1` and `ft2`) and now has access to the variables `a,b,c,i,j,k,l` and `m`.

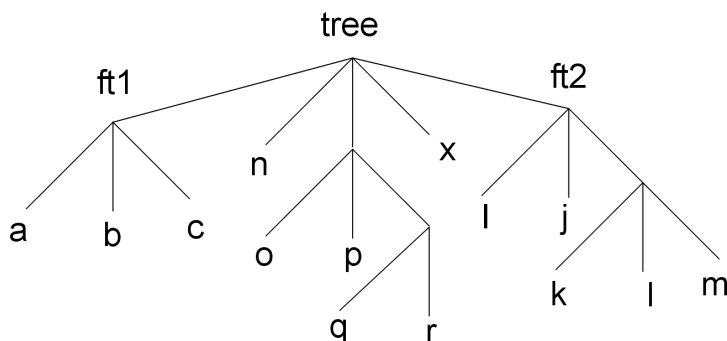

The `AddFriend` method has two parameters, the first is the tree name and the second is the name of the ROOT file where the friend tree is saved. `AddFriend` automatically opens

the friend file. If no file name is given, the tree called `ft1` is assumed to be in the same file as the original tree.

```
tree.AddFriend("ft1","friendfile1.root");
```

If the friend tree has the same name as the original tree, you can give it an alias in the context of the friendship:

```
tree.AddFriend("tree1 = tree","friendfile1.root");
```

Once the tree has friends, we can use `TTree::Draw` as if the friend's variables were in the original tree. To specify which tree to use in the `Draw` method, use the syntax:

```
<treeName>.<branchname>.<varname>
```

If the `variablename` is enough to uniquely identify the variable, you can leave out the tree and/or branch name.

For example, these commands generate a 3-d scatter plot of variable "var" in the `TTree` tree versus variable `v1` in `TTree` `ft1` versus variable `v2` in `TTree` `ft2`.

```
tree.AddFriend("ft1","friendfile1.root");
tree.AddFriend("ft2","friendfile2.root");
tree.Draw("var:ft1.v1:ft2.v2");
```

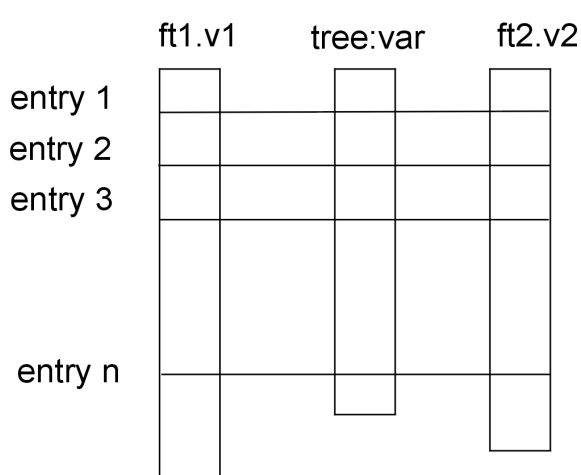

The picture illustrates the access of the tree and its friends with a `Draw` command.

When `AddFriend` is called, the `ROOT` file is automatically opened and the friend tree (`ft1`) header is read into memory. The new friend (`ft1`) is added to the list of friends of `tree`.

The number of entries in the friend must be equal or greater to the number of entries of the original tree. If the friend tree has fewer entries a warning is given and the missing entries are not included in the histogram.

To retrieve the list of friends from a tree use `TTree::GetListOfFriends`.

When the tree is written to file (`TTree::Write`), the friends list is saved with it. And when the tree is retrieved, the trees on the friends list are also retrieved and the friendship restored. When a tree is deleted, the elements of the friend list are also deleted. It is possible to declare a friend tree that has the same internal structure (same branches and leaves) as the original tree, and compare the same values by specifying the tree.

```
tree.Draw("var:ft1.var:ft2.var")
```

The example code is in `$ROOTSYS/tutorials/tree3.C`.

Here is the script:

```
void tree3w() {
// Example of a Tree where branches are variable length arrays
// A second Tree is created and filled in parallel.
// Run this script with
//     .x tree3.C
// In the function treer, the first Tree is open.
// The second Tree is declared friend of the first tree.
// TTree::Draw is called with variables from both Trees.

const Int_t kMaxTrack = 500;
Int_t ntrack;
Int_t stat[kMaxTrack];
Int_t sign[kMaxTrack];
Float_t px[kMaxTrack];
Float_t py[kMaxTrack];
Float_t pz[kMaxTrack];
Float_t pt[kMaxTrack];
Float_t zv[kMaxTrack];
Float_t chi2[kMaxTrack];
Double_t sumstat;

// create the first root file with a tree
TFile f("tree3.root","recreate");
TTree *t3 = new TTree("t3","Reconst ntuple");
t3->Branch("ntrack",&ntrack,"ntrack/I");
t3->Branch("stat",stat,"stat[ntrack]/I");
t3->Branch("sign",sign,"sign[ntrack]/I");
t3->Branch("px",px,"px[ntrack]/F");
t3->Branch("py",py,"py[ntrack]/F");
t3->Branch("pz",pz,"pz[ntrack]/F");
t3->Branch("zv",zv,"zv[ntrack]/F");
t3->Branch("chi2",chi2,"chi2[ntrack]/F");

// create the second root file with a different tree
TFile fr("tree3f.root","recreate");
TTree *t3f = new TTree("t3f","a friend Tree");
t3f->Branch("ntrack",&ntrack,"ntrack/I");
t3f->Branch("sumstat",&sumstat,"sumstat/D");
t3f->Branch("pt",pt,"pt[ntrack]/F");

// Fill the trees
for (Int_t i=0;i<1000;i++) {
    Int_t nt = gRandom->Rndm()*(kMaxTrack-1);
    ntrack = nt;
    sumstat = 0;
    // set the values in each track
    for (Int_t n=0;n<nt;n++) {
        stat[n] = n%3;
        sign[n] = i%2;
        px[n] = gRandom->Gaus(0,1);
        py[n] = gRandom->Gaus(0,2);
        pz[n] = gRandom->Gaus(10,5);
        zv[n] = gRandom->Gaus(100,2);
        chi2[n] = gRandom->Gaus(0,.01);
        sumstat += chi2[n];
        pt[n] = TMath::Sqrt(px[n]*px[n] + py[n]*py[n]);
    }
    t3->Fill();
    t3f->Fill();
}
//continued...
```



```

    // Write the two files
    t3->Print();
    f.cd();
    t3->Write();
    fr.cd();
    t3f->Write();
}

// Function to read the two files and add the friend
void tree3r()
{
    TFile *f = new TFile("tree3.root");
    TTree *t3 = (TTree*)f->Get("t3");

    // Add the second tree to the first tree as a friend
    t3->AddFriend("t3f", "tree3f.root");

    // Draw pz which is in the first tree and use pt
    // in the condition. pt is in the friend tree.
    t3->Draw("pz", "pt>3");
}

// This is executed when typing .x tree3.C
void tree3()
{
    tree3w();
    tree3r();
}

```

Example 4: A Tree with an Event Class

This example is a simplified version of `$ROOTSYS/test/MainEvent.cxx` and where Event objects are saved in a tree. The full definition of `Event` is in `$ROOTSYS/test/Event.h`. To execute this macro, you will need the library `$ROOTSYS/test/libEvent.so`. If it does not exist you can build the test directory applications by following the instruction in the `$ROOTSYS/test/README` file.

In this example we will show

- the difference in splitting or not splitting a branch
- how to read selected branches of the tree,
- how to print a selected entry

The Event Class

`Event` is a descendent of `TObject`. As such it inherits the data members of `TObject` and its methods such as `Dump()` and `Inspect()` and `Write()`. Also, because it inherits from `TObject` it can be a member of a collection.

To summarize, the advantages of inheriting from a `TObject` are:

- Inherit the `Write`, `Inspect`, and `Dump` methods
- Enables a class to be a member of a ROOT collection
- Enables RTTI

Below is the list of the `Event` data members. It contains a character array, several integers, a floating point number, and an `EventHeader` object. The `EventHeader` class is described in the following paragraph. `Event` also has two pointers, one to a `TClonesArray` of tracks and one to a histogram. The string `"->"` in the comment field of the members `*fTracks` and `*fH` instructs the automatic `Streamer` to assume that the objects `*fTracks` and `*fH` are never null pointers and that `fTracks->Streamer` can be used instead of the more time consuming form `R__b << fTracks`.

```

class Event : public TObject {

private:
    char                fType[20];
    Int_t               fNtrack;
    Int_t               fNseg;
    Int_t               fNvertex;
    UInt_t              fFlag;
    Float_t             fTemperature;
    EventHeader         fEvtHdr;
    TClonesArray        *fTracks;           //->
    TH1F                *fH;              //->
    Int_t               fMeasures[10];
    Float_t             fMatrix[4][4];
    Float_t             *fClosestDistance; // [fNvertex]
    static TClonesArray *fgTracks;
    static TH1F         *fgHist;
// ... list of methods
...
    ClassDef(Event,1) //Event structure
};

```

The EventHeader Class

The `EventHeader` class (also defined in `Event.h`) does not inherit from `TObject`. Beginning with ROOT 3.0, an object can be placed on a branch even though it does not inherit from `TObject`. In previous releases branches were restricted to objects inheriting from the `TObject`. However, it has always been possible to write a class not inheriting from `TObject` to a tree by encapsulating it in a `TObject` descending class as is the case in `EventHeader` and `Event`.

```

class EventHeader {

private:
    Int_t   fEvtNum;
    Int_t   fRun;
    Int_t   fDate;
// ... list of methods
    ClassDef(EventHeader,1) //Event Header
};

```

The Track Class

The `Track` class descends from `TObject` since tracks are in a `TClonesArray` (i.e. a ROOT collection class) and contains a selection of basic types and an array of vertices. It's `TObject` inheritance, enables `Track` to be in a collection, and in `Event` is a `TClonesArray` of `Tracks`.

```

class Track : public TObject {
private:
  Float_t  fPx;           //X component of the momentum
  Float_t  fPy;           //Y component of the momentum
  Float_t  fPz;           //Z component of the momentum
  Float_t  fRandom;       //A random track quantity
  Float_t  fMass2;        //The mass square of this particle
  Float_t  fBx;           //X intercept at the vertex
  Float_t  fBy;           //Y intercept at the vertex
  Float_t  fMeanCharge;   //Mean charge deposition of all hits
  Float_t  fXfirst;       //X coordinate of the first point
  Float_t  fXlast;        //X coordinate of the last point
  Float_t  fYfirst;       //Y coordinate of the first point
  Float_t  fYlast;        //Y coordinate of the last point
  Float_t  fZfirst;       //Z coordinate of the first point
  Float_t  fZlast;        //Z coordinate of the last point
  Float_t  fCharge;       //Charge of this track
  Float_t  fVertex[3];    //Track vertex position
  Int_t    fNpoint;       //Number of points for this track
  Short_t  fValid;        //Validity criterion

// method definitions ...
  ClassDef(Track,1)       //A track segment
};

```

Writing the Tree

We create a simple tree with two branches both holding `Event` objects. One is split and the other is not. We also create a pointer to an `Event` object (`event`).

```

void tree4w()
{
  // check to see if the event class is in the dictionary
  // if it is not load the definition in libEvent.so
  if (!TClassTable::GetDict("Event")) {
    gSystem->Load("$ROOTSYS/test/libEvent.so");
  }
  // create a Tree file tree4.root
  TFile f("tree4.root","RECREATE");

  // create a ROOT Tree
  TTree t4("t4","A Tree with Events");

  // create a pointer to an Event object
  Event *event = new Event();

  // create two branches, split one
  t4.Branch("event_branch", "Event", &event,16000,2);
  t4.Branch("event_not_split", "Event", &event,16000,0);

  // a local variable for the event type
  char etype[20];

  // fill the tree
  for (Int_t ev = 0; ev <100; ev++) {
    Float_t sigmat, sigmas;
    gRandom->Rannor(sigmat,sigmas);
    Int_t ntrack = Int_t(600 + 600 *sigmat/120.);
    Float_t random = gRandom->Rndm(1);
    sprintf(etype,"type%d",ev%5);

```

//continued ...

```

event->SetType(etype);
event->SetHeader(ev, 200, 960312, random);
event->SetNseg(Int_t(10*ntrack+20*sigmas));
event->SetNvertex(Int_t(1+20*gRandom->Rndm()));
event->SetFlag(UInt_t(random+0.5));
event->SetTemperature(random+20.);

for(UChar_t m = 0; m < 10; m++) {
    event->SetMeasure(m, Int_t(gRandom->Gaus(m,m+1)));
}

// fill the matrix
for(UChar_t i0 = 0; i0 < 4; i0++) {
    for(UChar_t i1 = 0; i1 < 4; i1++) {
        event->SetMatrix(i0,i1,gRandom->Gaus(i0*i1,1));
    }
}
// create and fill the Track objects
for (Int_t t = 0; t < ntrack; t++) event->AddTrack(random);
    t4.Fill(); // Fill the tree
    event->Clear(); // Clear before reloading event
}
f.Write(); // Write the file header
t4.Print(); // Print the tree contents
}

```

Reading the Tree

First, we check if the shared library with the class definitions is loaded. If not we load it. Then we read two branches, one for the number of tracks and one for the entire event. We check the number of tracks first, and if it meets our condition we read the entire event. We show the first entry that meets the condition.

```

void tree4r()
{
    // check to see if the event class is in the dictionary
    // if it is not load the definition in libEvent.so
    if (!TClassTable::GetDict("Event")) {
        gSystem->Load("$ROOTSYS/test/libEvent.so");
    }

    // read the tree generated with tree4w

    // note that we use "new" to create the TFile and
    // TTree objects, because we want to keep these
    // objects alive when we leave this function.
    TFile *f = new TFile("tree4.root");
    TTree *t4 = (TTree*)f->Get("t4");

    // create a pointer to an event object. This will be used
    // to read the branch values.
    Event *event = new Event();

    // get two branches and set the branch address
    TBranch *bntrack = t4->GetBranch("fNtrack");
    TBranch *branch = t4->GetBranch("event_split");
    branch->SetAddress(&event);

    Int_t nevent = t4->GetEntries();
    Int_t nselected = 0;
    Int_t nb = 0;
}
//continued ...

```

```

for (Int_t i=0; i<nevent; i++) {
  //read branch "fNtrack"only
  bntrack->GetEntry(i);

  //reject events with more than 587 tracks
  if (event->GetNtrack() > 587)continue;

  //read complete accepted event in memory
  nb += t4->GetEntry(i);
  nselected++;

  //print the first accepted event
  if (nselected == 1) t4->Show();

  //clear tracks array
  event->Clear();
}

if (gROOT->IsBatch()) return;
new TBrowser();
t4->StartViewer();
}

```

Now, let's see what the tree looks like in the tree viewer.

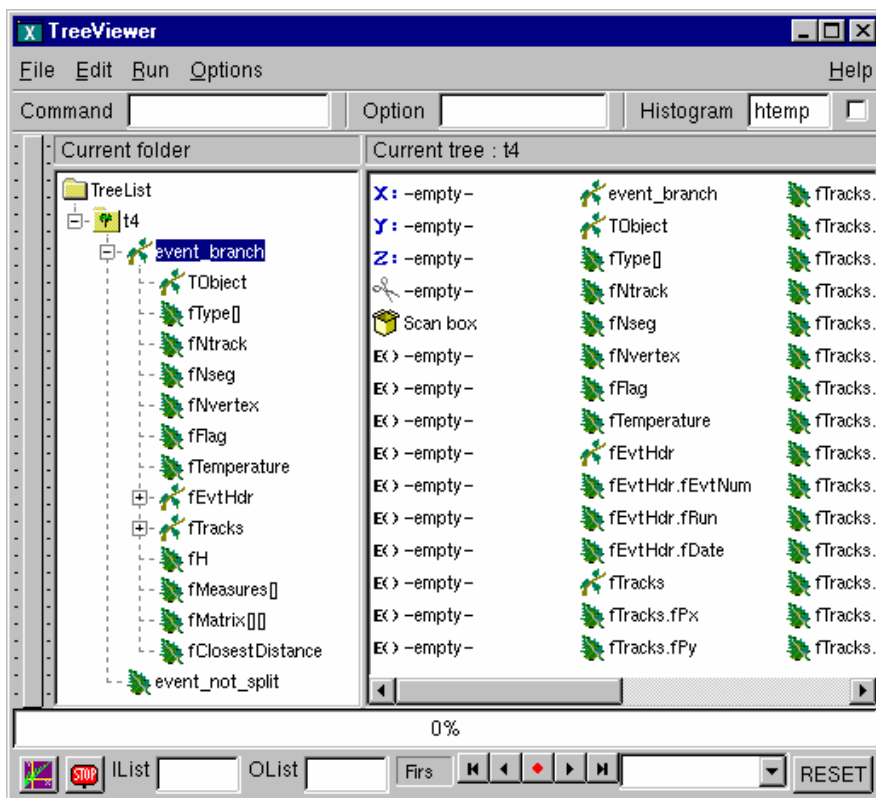

You can see the two branches in the tree in the left panel: the `event_branch` is split and hence expands when clicked on. The other branch `event_not_split` is not expandable and we can not browse the data members.

The `TClonesArray` of tracks `fTracks` is also split because we set the split level to 2.

The output on the command line is the result of `tree4->Show`. It shows the first entry with more than 587 tracks:

```
=====> EVENT:26
event_split      =
fUniqueID       = 0
fBits           = 50331648
fType[20]       = 116 121 112 101 49 0 0 0 0 0 0 0 0 0 0 0 0 0 0 0
fNtrack         = 585
fNseg           = 5834
fNvertex        = 17
fFlag           = 0
fTemperature    = 20.044315
fEvtHdr.fEvtNum = 26
fEvtHdr.fRun    = 200
fEvtHdr.fDate   = 960312
fTracks         = 585
fTracks.fUniqueID = 0, 0, 0, 0, 0, 0, 0, 0, 0, 0, 0
...
```

Trees in Analysis

The methods `TTree::Draw`, `TTree::MakeClass` and `TTree::MakeSelector` are available for data analysis using trees.

The `TTree::Draw` method is a powerful yet simple way to look and draw the trees contents. It enables you to plot a variable (a leaf) with just one line of code. However, the Draw method falls short once you want to look at each entry and design more sophisticated acceptance criteria for your analysis. For these cases, you can use `TTree::MakeClass`. It creates a class that loops over the trees entries one by one. You can then expand it to do the logic of your analysis.

The `TTree::MakeSelector` is the recommended method for ROOT data analysis. It is especially important for large data set in a parallel processing configuration where the analysis is distributed over several processors and you can specify which entries to send to each processor. With `MakeClass` the user has control over the event loop, with `MakeSelector` the tree is in control of the event loop.

Simple Analysis Using TTree::Draw

We will use the tree in `staff.root` which was made by the macro in `$ROOTSYS/tutorials/staff.C`.

First, open the file and lists its contents.

```
root[] TFile f ("staff.root")
root[] f.ls()
TFile**      staff.root
TFile*       staff.root
KEY: TTree   tree;1  staff data from ascii file
```

We can see the `TTree`"tree" in the file. We will use it to experiment with the `TTree::Draw` method, so let's create a pointer to it:

```
root[] TTree *MyTree = tree
```

CINT allows us to simply get the object by using it. Here we define a pointer to a `TTree` object and assign it the value of "tree", the `TTree` in the file. CINT looks for "tree" and returns it. To show the different Draw options, we create a canvas with four sub-pads. We will use one sub-pad for each Draw command.

```
root[] TCanvas *myCanvas = new TCanvas ()
root[] myCanvas->Divide(2,2)
```

We activate the first pad with the `TCanvas::cd` statement:

```
root[] myCanvas->cd(1)
```

We then draw the variable `cost`:

```
root[] MyTree->Draw("cost")
```

As you can see, the last call `TTree::Draw` has only one parameter. It is a string containing the leaf name. A histogram is automatically created as a result of a `TTree::Draw`. The style of the histogram is inherited from the `TTree` attributes and the current style (`gStyle`) is ignored. The `TTree` gets its attributes from the current `TStyle` at the time it was created. You can call the method `TTree::UseCurrentStyle` to change to the current style rather than the `TTree` style. (See `gStyle`; see also Graphics and Graphic User Interface)

In this next segment we activate the second pad and draw a scatter plot variables:

```
root[] myCanvas->cd(2)
root[] MyTree->Draw("cost:age")
```

This signature still only has one parameter, but it now has two dimensions separated by a colon ("`x:y`"). The item to be plotted can be an expression not just a simple variable. In general, this parameter is a string that contains up to three expressions, one for each dimension, separated by a colon ("`e1:e2:e3`"). A list of examples follows this introduction.

Using Selection with `TTree::Draw`

Change the active pad to 3, and add a selection to the list of parameters of the draw command.

```
root[] myCanvas->cd(3)
root[] MyTree->Draw("cost:age","nation == 3");
```

This will draw the `cost` vs. `age` for the entries where the nation is equal to 3. You can use any C++ operator, plus some functions defined in `TFormula`, in the selection parameter.

The value of the selection is used as a weight when filling the histogram. If the expression includes only Boolean operations as in the example above, the result is 0 or 1. If the result is 0, the histogram is not filled. In general, the expression is:

```
Selection = "weight *(boolean expression) "
```

If the Boolean expression evaluates to true, the histogram is filled with a weight. If the weight is not explicitly specified it is assumed to be 1.

For example, this selection will add 1 to the histogram if `x` is less than `y` and the square root of `z` is less than 3.2.

```
"x<y && sqrt(z)>3.2"
```

On the other hand, this selection will add `x+y` to the histogram if the square root of `z` is larger than 3.2.

```
"(x+y) *(sqrt(z)>3.2) "
```

The `Draw` method has its own parser, and it only looks in the current tree for variables. This means that any variable used in the selection must be defined in the tree. You cannot use an arbitrary global variable in the `TTree::Draw` method.

Using TCut Objects in TTree::Draw

The `TTree::Draw` method also accepts `TCut` objects. A `TCut` is a specialized string object used for `TTree` selections. A `TCut` object has a name and a title. It does not have any data members in addition to what it inherits from `TNamed`. It only adds a set of operators to do logical string concatenation. For example, assume:

```
TCut cut1 = "x<1"
TCut cut2 = "y>2"
```

then

```
cut1 && cut2
//result is the string "(x<1)&&(y>2)"
```

Operators `=`, `+=`, `+`, `*`, `!`, `&&`, `||` are overloaded, here are some examples:

```
root[] TCut c1 = "x < 1"
root[] TCut c2 = "y < 0"
root[] TCut c3 = c1 && c2
root[] MyTree.Draw("x", c1)
root[] MyTree.Draw("x", c1 || "x>0")
root[] MyTree.Draw("x", c1 && c2)
root[] MyTree.Draw("x", "(x + y)" * (c1 && c2))
```

Accessing the Histogram in Batch Mode

The `TTree::Draw` method creates a histogram called `htemp` and puts it on the active pad. In a batch program, the histogram `htemp` created by default, is reachable from the current pad.

```
// draw the histogram
nt->Draw("x", "cuts");
// get the histogram from the current pad
TH1F htemp = (TH1F*)gPad->GetPrimitive("htemp");
// now we have full use of the histogram
htemp->GetEntries();
```

If you pipe the result of the `TTree::Draw` into a histogram, the histogram is also available in the current directory. You can do:

```
// Draw the histogram and fill hnew with it
nt->Draw("x>>hnew", "cuts");
// get hnew from the current directory
TH1F *hnew = (TH1F*)gDirectory->Get("hnew");
// or get hnew from the current Pad
TH1F *hnew = (TH1F*)gPad->GetPrimitive("hnew");
```

Using Draw Options in TTree::Draw

The next parameter is the draw option for the histogram:

```
root[] myCanvas->cd(4)
root[] MyTree->Draw("cost:age", "nation == 3", "surf2");
```

The draw options are the same as for `TH1::Draw`, and they are listed in the section: Draw Options in the chapter on [Histograms](#). In addition to the draw options defined in `TH1`, there are three more. The 'prof' and 'profs' draw a profile histogram (`TProfile`) rather than a regular 2D histogram (`TH2D`) from an expression with two variables. If the expression has three variables, a `TProfile2D` is generated.

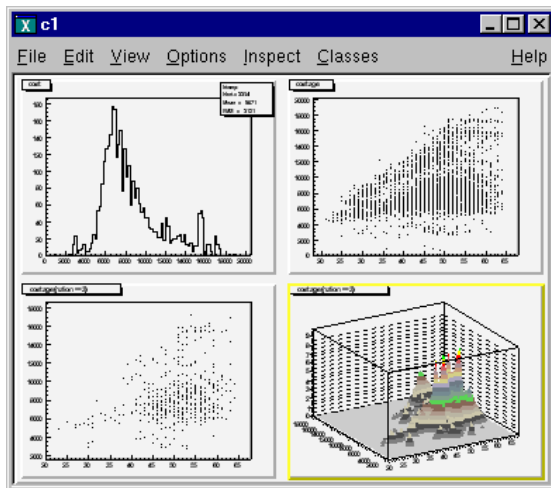

The 'profs' generates a **TProfile** with error on the spread. The 'prof' option generates a **TProfile** with error on the mean. The "goff" option suppresses generating the graphics. You can combine the draw options in a list separated by commas. After typing the lines above, you should now have a canvas that looks like this.

Superimposing Two Histograms

When superimposing two 2-D histograms inside a script with **TTree::Draw** and using the "same" option, you will need to update the pad between **Draw** commands.

```
// superimpose two 2D scatter plots
{
  // Create a 2D histogram and fill it with random numbers
  TH2 *h2 = new TH2D ("h2", "2D histo", 100, 0, 70, 100, 0, 20000);
  for (Int_t i = 0; i < 10000; i++)
    h2->Fill(gRandom->Gaus(40,10), gRandom->Gaus(10000, 3000));

  // set the color to differentiate it visually
  h2->SetMarkerColor(kGreen);
  h2->Draw();

  // Open the example file and get the tree
  TFile f("staff.root");
  TTree *myTree = (TTree*)f.Get("tree");

  // the update is needed for the next draw command to work properly
  gPad->Update();
  myTree->Draw("cost:age", "", "same");
}
```

In this example, `h2->Draw` is only adding the object `h2` to the pad's list of primitives. It does not paint the object on the screen. However, **TTree::Draw** when called with option "same" gets the current pad coordinates to build an intermediate histogram with the right limits. Since nothing has been painted in the pad yet, the pad limits have not been computed. Calling `pad->Update` forces the painting of the pad and allows **TTree::Draw** to compute the right limits for the intermediate histogram.

Setting the Range in TTree::Draw

There are two more optional parameters to the **TTree::Draw** method: one is the number of entries and the second one is the entry to start with. For example this command draws 1000 entries starting with entry 100:

```
myTree->Draw("cost:age", "", "", 1000, 100);
```

TTree::Draw Examples

The examples below use the `Event.root` file generated by the `$ROOTSYS/test/Event` executable and the `Event`, `Track`, and `EventHeader` class definitions are in `$ROOTSYS/test/Event.h`.

The commands have been tested on the split levels 0, 1, and 9. Each command is numbered and referenced by the explanations immediately following the examples.

```
// Data members and methods
1  tree->Draw("fNtrack");
2  tree->Draw("event.GetNtrack()");
3  tree->Draw("GetNtrack()");

4  tree->Draw("fH.fXaxis.fXmax");
5  tree->Draw("fH.fXaxis.GetXmax()");
6  tree->Draw("fH.GetAxis().fXmax");
7  tree->Draw("GetHistogram().GetXaxis().GetXmax()");

// expressions in the selection paramter
8  tree->Draw("fTracks.fPx","fEvtHdr.fEvtNum%10 == 0");
9  tree->Draw("fPx","fEvtHdr.fEvtNum%10 == 0");

// Two dimensional arrays
// fMatrix is defined as:
// Float_t fMatrix[4][4]; in Event class
10 tree->Draw("fMatrix");
11 tree->Draw("fMatrix[ ][ ]");
12 tree->Draw("fMatrix[2][2]");
13 tree->Draw("fMatrix[ ][0]");
14 tree->Draw("fMatrix[1][ ]");

// using two arrays...
// Float_t fVertex[3]; in Track class
15 tree->Draw("fMatrix - fVertex");
16 tree->Draw("fMatrix[2][1] - fVertex[5][1]");
17 tree->Draw("fMatrix[ ][1] - fVertex[5][1]");
18 tree->Draw("fMatrix[2][ ] - fVertex[5][ ]");
19 tree->Draw("fMatrix[ ][2] - fVertex[ ][1]");
20 tree->Draw("fMatrix[ ][2] - fVertex[ ][ ]");
21 tree->Draw("fMatrix[ ][ ] - fVertex[ ][ ]");
// Float_t fVertex[3]; in Track class
15 tree->Draw("fMatrix - fVertex");
16 tree->Draw("fMatrix[2][1] - fVertex[5][1]");
17 tree->Draw("fMatrix[ ][1] - fVertex[5][1]");
18 tree->Draw("fMatrix[2][ ] - fVertex[5][ ]");
19 tree->Draw("fMatrix[ ][2] - fVertex[ ][1]");
20 tree->Draw("fMatrix[ ][2] - fVertex[ ][ ]");
21 tree->Draw("fMatrix[ ][ ] - fVertex[ ][ ]");

// variable length arrays
22 tree->Draw("fClosestDistance");
23 tree->Draw("fClosestDistance[fNvertex/2]");

// mathematical expressions
24 tree->Draw("sqrt(fPx*fPx + fPy*fPy + fPz*fPz)");

// strings
25 tree->Draw("fEvtHdr.fEvtNum","fType==\"type1\" ");
26 tree->Draw("fEvtHdr.fEvtNum","strstr(fType,\"1\" ");

// continued...
```

```

// Where fPoints is defined in the track class:
//     Int_t fNpoint;
//     Int_t *fPoints; [fNpoint]
27 tree->Draw("fTracks.fPoints");
28 tree->Draw("fTracks.fPoints -
           fTracks.fPoints[][fAvgPoints]");
29 tree->Draw("fTracks.fPoints[2][]- fTracks.fPoints[][55]");
30 tree->Draw("fTracks.fPoints[][] - fTracks.fVertex[][]");

// Selections
31 tree->Draw("fValid&0x1","(fNvertex>10) && (fNseg<=6000)")
32 tree->Draw("fPx","(fBx>.4) || (fBy<=-.4)");
33 tree->Draw("fPx","fBx*fBx*(fBx>.4) + fBy*fBy*(fBy<=-.4)");
34 tree->Draw("fVertex","fVertex>10")
35 tree->Draw("fPx[600]")
36 tree->Draw("fPx[600]","fNtrack>600")

// Alphanumeric bin histogram
37 tree->Draw("Nation")

// where Nation and Division is a char* intended to be used
// as a string
38 tree->Draw("MyByte + 0")
// where MyByte is a char* intended to be used as a byte

```

Explanations:

1. `tree->Draw("fNtrack");`

It fills the histogram with the number of tracks for each entry. `fNtrack` is a member of event.

2. `tree->Draw("event.GetNtrack()");`

Same as case 1, but use the method of event to get the number of tracks. When using a method, you can include parameters for the method as long as the parameters are literals.

3. `tree->Draw("GetNtrack()");`

Same as case 2, the object of the method is not specified. The command uses the first instance of the `GetNtrack` method found in the objects stored in the tree. We recommend using this shortcut only if the method name is unique.

4. `tree->Draw("fH.fXaxis.fXmax");`

Draw the data member of a data member. In the tree, each entry has a histogram. This command draws the maximum value of the X-axis for each histogram.

5. `tree->Draw("fH.fXaxis.GetXmax()");`

Same as case 4, but use the method of a data member.

6. `tree->Draw("fH.GetXaxis().fXmax");`

The same as case 4: a data member of a data member retrieved by a method.

7. `tree->Draw("GetHistogram().GetXaxis().GetXmax()");`

Same as case 4, using only methods.

8. `tree->Draw("fTracks.fPx","fEvtHdr.fEvtNum%10 == 0");`

Use data members in the expression and in the selection parameter to plot `fPx` or all tracks in every 10th entry. Since `fTracks` is a `TClonesArray` of `Tracks`, there will be `d` values of `fPx` for each entry.

9. `tree->Draw("fPx","fEvtHdr.fEvtNum%10 == 0");`

Same as case 8, use the name of the data member directly.

10. `tree->Draw("fMatrix");`

When the index of the array is left out or when empty brackets are used [], all values of the array are selected. Draw all values of `fMatrix` for each entry in the tree. If `fMatrix` is defined as: `Float_t fMatrix[4][4]`, all 16 values are used for each entry.

11. `tree->Draw("fMatrix[][]");`

The same as case 10, all values of `fMatrix` are drawn for each entry.

12. `tree->Draw("fMatrix[2][2]");`

The single element at `fMatrix[2][2]` is drawn for each entry.

13. `tree->Draw("fMatrix[][0]");`

Four elements of `fMatrix` are used: `fMatrix[1][0]`, `fMatrix[2][0]`, `fMatrix[3][0]`, `fMatrix[4][0]`.

14. `tree->Draw("fMatrix[1][]");`

Four elements of `fMatrix` are used: `fMatrix[1][0]`, `fMatrix[1][2]`, `fMatrix[1][3]`, `fMatrix[1][4]`.

15. `tree->Draw("fMatrix - fVertex");`

With two arrays and unspecified element numbers, the number of selected values is the minimum of the first dimension times the minimum of the second dimension. In this case `fVertex` is also a two dimensional array since it is a data member of the tracks array. If `fVertex` is defined in the track class as: `Float_t *fVertex[3]`, it has `fNtracks x 3` elements. `fMatrix` has `4 x 4` elements. This case, draws 4 (the smaller of `fNtrack` and 4) times 3 (the smaller of 4 and 3), meaning 12 elements per entry. The selected values for each entry are:

```
fMatrix[0][0] - fVertex[0][0]
fMatrix[0][1] - fVertex[0][1]
fMatrix[0][2] - fVertex[0][2]
fMatrix[1][0] - fVertex[1][0]
fMatrix[1][1] - fVertex[1][1]
fMatrix[1][2] - fVertex[1][2]
fMatrix[2][0] - fVertex[2][0]
fMatrix[2][1] - fVertex[2][1]
fMatrix[2][2] - fVertex[2][2]
fMatrix[3][0] - fVertex[3][0]
fMatrix[3][1] - fVertex[3][1]
fMatrix[3][2] - fVertex[3][2]
```

16. `tree->Draw("fMatrix[2][1] - fVertex[5][1]");`

This command selects one value per entry.

17. `tree->Draw("fMatrix[][1] - fVertex[5][1]");`

The first dimension of the array is taken by the `fMatrix`.

```
fMatrix[0][1] - fVertex[5][1]
fMatrix[1][1] - fVertex[5][1]
fMatrix[2][1] - fVertex[5][1]
fMatrix[3][1] - fVertex[5][1]
```

18. `tree->Draw("fMatrix[2][] - fVertex[5][]");`

The first dimension minimum is 2, and the second dimension minimum is 3 (from `fVertex`). Three values are selected from each entry:

```
fMatrix[2][0] - fVertex[5][0]
fMatrix[2][1] - fVertex[5][1]
fMatrix[2][2] - fVertex[5][2]
```

19. `tree->Draw("fMatrix[][2] - fVertex[][1]")`

This is similar to case 18. Four values are selected from each entry:

```
fMatrix[0][2] - fVertex[0][1]
fMatrix[1][2] - fVertex[1][1]
fMatrix[2][2] - fVertex[2][1]
fMatrix[3][2] - fVertex[3][1]
```

20. `tree->Draw("fMatrix[][2] - fVertex[][]")`

This is similar to case 19. Twelve values are selected (4x3) from each entry:

```
fMatrix[0][2] - fVertex[0][0]
fMatrix[0][2] - fVertex[0][1]
fMatrix[0][2] - fVertex[0][2]
fMatrix[1][2] - fVertex[1][0]
fMatrix[1][2] - fVertex[1][1]
fMatrix[1][2] - fVertex[1][2]
fMatrix[2][2] - fVertex[2][0]
fMatrix[2][2] - fVertex[2][1]
fMatrix[2][2] - fVertex[2][2]
fMatrix[3][2] - fVertex[3][0]
fMatrix[3][2] - fVertex[3][1]
fMatrix[3][2] - fVertex[3][2]
```

21. `tree->Draw("fMatrix[][] - fVertex[][]")`

This is the same as case 15. The first dimension minimum is 4 (from `fMatrix`), and the second dimension minimum is 3 (from `fVertex`). Twelve values are selected from each entry.

22. `tree->Draw("fClosestDistance")`

This event data member `fClosestDistance` is a variable length array: `Float_t *fClosestDistance; // [fNvertex]`

This command selects all elements, but the number per entry depends on the number of vertices of that entry.

23. `tree->Draw("fClosestDistance[fNvertex/2]")`

With this command the element at `fNvertex/2` of the `fClosestDistance` array is selected. Only one per entry is selected.

24. `tree->Draw("sqrt(fPx*fPx + fPy*fPy + fPz*fPz)")`

This command shows the use of a mathematical expression. It draws the square root of the sum of the product.

25. `tree->Draw("fEvtHdr.fEvtNum", "fType=="type1" ")`

You can compare strings, using the symbols `==` and `!=`, in the first two parameters of the `Draw` command (`TTreeFormula`). In this case, the event number for 'type1' events is plotted.

26. `tree->Draw("fEvtHdr.fEvtNum", "strstr(fType,\"1\") ")`

To compare strings, you can also use `strstr`. In this case, events having a '1' in `fType` are selected.

27. `tree->Draw("fTracks.fPoints")`

If `fPoints` is a data member of the `Track` class declared as:

```
Int_t fNpoint;
Int_t *fPoints; [fNpoint]
```

The size of the array `fPoints` varies with each track of each event. This command draws all the value in the `fPoints` arrays.

28. tree->Draw("fTracks.fPoints - fTracks.fPoints[][fAvgPoints]");

When `fAvgPoints` is a data member of the `Event` class, this example selects:

```
fTracks[0].fPoints[0] - fTracks[0].fPoint[fAvgPoints]
fTracks[0].fPoints[1] - fTracks[0].fPoint[fAvgPoints]
fTracks[0].fPoints[2] - fTracks[0].fPoint[fAvgPoints]
fTracks[0].fPoints[3] - fTracks[0].fPoint[fAvgPoints]
fTracks[0].fPoints[4] - fTracks[0].fPoint[fAvgPoints]
...
fTracks[0].fPoints[max0] - fTracks[0].fPoint[fAvgPoints]

fTracks[1].fPoints[0] - fTracks[1].fPoint[fAvgPoints]
fTracks[1].fPoints[1] - fTracks[1].fPoint[fAvgPoints]
fTracks[1].fPoints[2] - fTracks[1].fPoint[fAvgPoints]
fTracks[1].fPoints[3] - fTracks[1].fPoint[fAvgPoints]
fTracks[1].fPoints[4] - fTracks[1].fPoint[fAvgPoints]
...
fTracks[1].fPoints[max1] - fTracks[1].fPoint[fAvgPoints]
...
fTracks[fNtrack-1].fPoints[0]
    - fTracks[fNtrack-1].fPoint[fAvgPoints]
fTracks[fNtrack-1].fPoints[1]
    - fTracks[fNtrack-1].fPoint[fAvgPoints]
fTracks[fNtrack-1].fPoints[2]
    - fTracks[fNtrack-1].fPoint[fAvgPoints]
fTracks[fNtrack-1].fPoints[3]
    - fTracks[fNtrack-1].fPoint[fAvgPoints]
fTracks[fNtrack-1].fPoints[4]
    - fTracks[fNtrack-1].fPoint[fAvgPoints]
...
fTracks[fNtrack-1].fPoints[maxn]
    - fTracks[fNtrack-1].fPoint[fAvgPoints]
```

Where `max0`, `max1`, ... `max n`, is the size of the `fPoints` array for the respective track.

29. tree->Draw("fTracks.fPoints[2][] - fTracks.fPoints[][55]");

For each event, this expression is selected:

```
fTracks[2].fPoints[0] - fTracks[0].fPoints[55]
fTracks[2].fPoints[1] - fTracks[1].fPoints[55]
fTracks[2].fPoints[2] - fTracks[2].fPoints[55]
fTracks[2].fPoints[3] - fTracks[3].fPoints[55]
...
fTracks[2].fPoints[max] - fTracks[max].fPoints[55]
```

where `max` is the minimum of `fNtrack` and `fTracks[2].fNpoint`.

30. tree->Draw("fTracks.fPoints[][] - fTracks.fVertex[][]");

For each event and each track, this expression is selected. It is the difference between `fPoints` and of `fVertex`. The number of elements used for each track is the minimum of `fNpoint` and 3 (the size of the `fVertex` array).

```
fTracks[0].fPoints[0] - fTracks[0].fVertex[0]
fTracks[0].fPoints[1] - fTracks[0].fVertex[1]
fTracks[0].fPoints[2] - fTracks[0].fVertex[2]
// with fTracks[1].fNpoint==7
```

```

fTracks[1].fPoints[0] - fTracks[1].fVertex[0]
fTracks[1].fPoints[1] - fTracks[1].fVertex[1]
fTracks[1].fPoints[2] - fTracks[1].fVertex[2]
// with fTracks[1].fNpoint==5

fTracks[2].fPoints[0] - fTracks[1].fVertex[0]
fTracks[2].fPoints[1] - fTracks[1].fVertex[1]
// with fTracks[2].fNpoint==2

fTracks[3].fPoints[0] - fTracks[3].fVertex[0]
// with fTracks[3].fNpoint==1

fTracks[4].fPoints[0] - fTracks[4].fVertex[0]
fTracks[4].fPoints[1] - fTracks[4].fVertex[1]
fTracks[4].fPoints[2] - fTracks[4].fVertex[2]
// with fTracks[4].fNpoint==3

```

31. `tree->Draw("fValid&0x1", "(fNvertex>10) && (fNseg<=6000)")`

You can use bit patterns (&, |, <<) or Boolean operation.

32. `tree->Draw("fPx", "(fBx>.4) || (fBy<=-.4)");`

33. `tree->Draw("fPx", "fBx*fBx*(fBx>.4) + fBy*fBy*(fBy<=-.4)");`

The selection argument is used as a weight. The expression returns a multiplier and in case of a Boolean the multiplier is either 0 (for false) or 1 (for true). The first command draws `fPx` for the range between 0.4 and -0.4, the second command draws `fPx` for the same range, but adds a weight using the result of the second expression.

34. `tree->Draw("fVertex", "fVertex>10")`

When using arrays in the selection and the expression, the selection is applied to each element of the array.

```

if (fVertex[0]>10) fVertex[0]
if (fVertex[1]>10) fVertex[1]
if (fVertex[2]>10) fVertex[2]

```

35. `tree->Draw("fPx[600]")`

36. `tree->Draw("fPx[600]", "fNtrack > 600")`

When using a specific element for a variable length array the entries with less elements are ignored. Thus these two commands are equivalent.

37. `tree->Draw("Nation")`

`Nation` is a `char*` branch. When drawing a `char*` it will plot an alphanumeric histogram, of the different value of the string `Nation`. The axis will have the `Nation` values (see [Alphanumeric Histograms](#) in the Histogram chapter).

38. `tree->Draw("MyChar +0")`

If you want to plot a `char*` variable as a byte rather than a string, you can use the syntax above.

Creating an Event List

The `TTree::Draw` method can also be used to build a list of the entries. When the first argument is preceded by ">>" ROOT knows that this command is not intended to draw anything, but to save the entries in a list with the name given by the first argument. The resulting list is a `TEventList`, and is added to the objects in the current directory.

For example, to create a `TEventList` of all entries with more than 600 tracks:

```

root[] TFile *f = new TFile("Event.root")
root[] T->Draw(">> myList", " fNtrack > 600")

```

This list contains the entry number of all entries with more than 600 tracks.

To see the entry numbers use the `Print("all")` command.

```
root[] myList->Print("all")
```

When using the ">>" whatever was in the `TEventList` is overwritten. The `TEventList` can be grown by using the ">>+" syntax.

For example to add the entries, with exactly 600 tracks:

```
root[] T->Draw(">>+ myList", " fNtrack == 600")
```

If the Draw command generates duplicate entries, they are not added to the list.

```
root[] T->Draw(">>+ myList", " fNtrack > 610")
```

This command does not add any new entries to the list because all entries with more than 610 tracks have already been found by the previous command for entries with more than 600 tracks.

Using an Event List

The `TEventList` can be used to limit the `TTree` to the events in the list. The `SetEventList` method tells the tree to use the event list and hence limits all subsequent `TTree` methods to the entries in the list. In this example, we create a list with all entries with more than 600 tracks and then set it so the Tree will use this list. To reset the `TTree` to use all events use `SetEventList(0)`.

1) Let's look at an example. First, open the file and draw the `fNtrack`.

```
root[] TFile *f = new TFile("Event.root")
root[] T->Draw("fNtrack ")
```

2) Now, put the entries with over 600 tracks into a `TEventList` called `myList`. We get the list from the current directory and assign it to a variable list.

```
root[] T->Draw(">>myList", " fNtrack > 600")
root[] TEventList *list=(TEventList*)gDirectory->Get("myList")
```

3) Instruct the tree T to use the new list and draw it again. Note that this is exactly the same Draw command. The list limits the entries.

```
root[] T->SetEventList(list)
root[] T->Draw("fNtrack ")
```

You should now see a canvas that looks like this one.

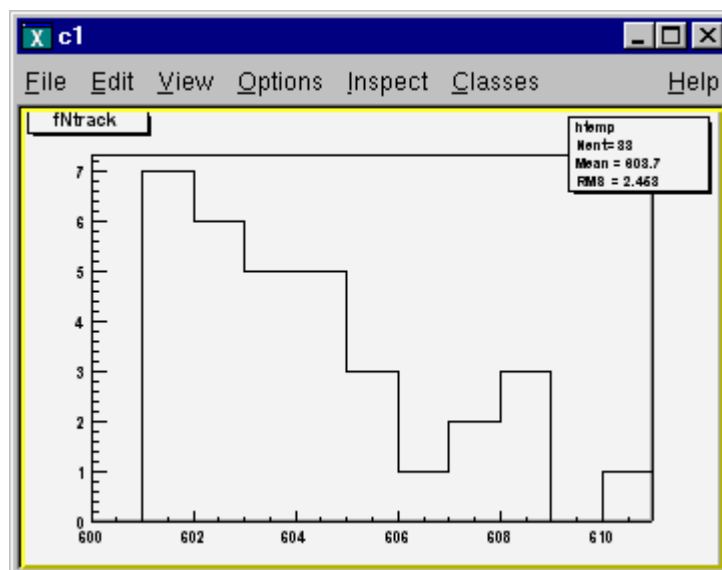

Filling a Histogram

The `TTree::Draw` method can also be used to fill a specific histogram. The syntax is:

```
root[] TFile *f = new TFile("Event.root")
root[] T->Draw("fNtrack >> myHisto")
root[] myHisto->Print()
TH1.Print Name= myHisto, Entries= 100, Total sum= 100
```

As we can see, this created a `TH1`, called `myHisto`. If you want to append more entries to the histogram, you can use this syntax:

```
root[] T->Draw("fNtrack >>+ myHisto")
```

If you do not create a histogram ahead of time, ROOT will create one at the time of the Draw command (as is the case above). If you would like to draw the variable into a specific histogram where you, for example, set the range and bin number, you can define the histogram ahead of time and use it in the Draw command. The histogram has to be in the same directory as the tree.

```
root[] TH1 *h1 = new TH1("h1", "h1", 50, 0., 150.);
root[] T->Draw("fNtrack>> h1");
```

When you project a `TTree` into a histogram, the histogram inherits the `TTree` attributes and not the current style attributes. This allows you to project two Trees with different attributes into the same picture. You can call the method `TTree::UseCurrentStyle` to change the histogram to use the current style (`gStyle`, see the Chapter [Graphics and Graphic User Interfaces](#)).

The binning of the newly created histogram can be specified in two ways. You can set a default in the `.rootrc` and/or you can add the binning information in the `TTree::Draw` command.

To set number of bins default for the 1-d,2-d,3-d histograms can be specified in the `.rootrc` file via the environment variables, e.g.:

```
# default binnings
Hist.Binning.1D.x: 100

Hist.Binning.2D.x: 40
Hist.Binning.2D.y: 40
Hist.Binning.2D.Prof: 100

Hist.Binning.3D.x: 20
Hist.Binning.3D.y: 20
Hist.Binning.3D.z: 20
Hist.Binning.3D.Profx: 100
Hist.Binning.3D.Profy: 100
```

To set the number of bins for a specific histogram when using `TTree::Draw`, add up to nine numbers following the histogram name. The numbers meaning is:

- 1 bins in x-direction
- 2 lower limit in x-direction
- 3 upper limit in x-direction
- 4-6 same for y-direction
- 7-9 same for z-direction

When a bin number is specified, the value becomes the default. Any of the numbers can be skipped.

For example:

```
tree.Draw("sqrt(x)>>hsqrt(500,10,20)";
// plot sqrt(x) between 10 and 20 using 500 bins

tree.Draw("sqrt(x):sin(y)>>hsqrt(100,10,,50,.1,.5)";
// plot sqrt(x) against sin(y)
// 100 bins in x-direction; lower limit on x-axis is 10;
// no upper limit
// 50 bins in y-direction; lower limit on y-axis is .1;
// upper limit is .5
```

When the name is followed by binning information, appending the histogram with a "+", will not reset `hsqrt`, but will continue to fill it.

```
tree.Draw("sqrt(x)>>+hsqrt","y>0");
```

This works for 1-D, 2-D and 3-D histograms.

Projecting a Histogram

If you would like to fill a histogram, but not draw it you can use the `TTree::Project()` method.

```
root[] T->Project("quietHisto","fNtrack")
```

Making a Profile Histogram

In case of a two dimensional expression, you can generate a `TProfile` histogram instead of a two dimensional histogram by specifying the 'prof' or 'profs' option. The `prof` option is automatically selected when the output is redirected into a `TProfile`. For example `y:x>>pf` where `pf` is an existing `TProfile` histogram.

Tree Information

Once we have drawn a tree, we can get information about the tree. These are the methods used to get information from a drawn tree `TTree`:

- `GetSelectedRows`: Returns the number of entries accepted by the selection expression. In case where no selection was specified, it returns the number of entries processed.
- `GetV1`: Returns a pointer to the float array of the first variable.
- `GetV2`: Returns a pointer to the float array of second variable
- `GetV3`: Returns a pointer to the float array of third variable.
- `GetW`: Returns a pointer to the float array of Weights where the weight equals the result of the selection expression.

To read the drawn values of `fNtrack` into an array, and loop through the entries follow the lines below. First, open the file and draw the `fNtrack` variable:

```
root[] TFile *f = new TFile("Event.root")
root[] T->Draw("fNtrack")
```

Then declare a pointer to a float and use the `GetV1` method to retrieve the first dimension of the tree. In this example we only drew one dimension (`fNtrack`) if we had drawn two, we could use `GetV2` to get the second one.

```
root[] Float_t *a
root[] a = T->GetV1()
```

Loop through the first 10 entries and print the values of `fNtrack`:

```
root[] for (int i = 0; i < 10; i++)
root[]     cout << a[i] << " "
root[]     cout << endl // need an endl to see the values
594 597 606 595 604 610 604 602 603 596
```

By default, `TTTree::Draw` creates these arrays with `fEstimate` words where `fEstimate` can be set via `TTTree::SetEstimate`. If you have more entries than `fEstimate` only the first `fEstimate` selected entries will be stored in the arrays. The arrays are used as buffers. When `fEstimate` entries have been processed, ROOT scans the buffers to compute the minimum and maximum of each coordinate and creates the corresponding histograms. You can use these lines to read all entries into these arrays:

```
root[] Int_t nestimate = (Int_t)T->GetEntries();
root[] T->SetEstimate(nestimate);
```

Obviously, this will not work if the number of entries is very large. This technique is useful in several cases, for example if you want to draw a graph connecting all the x, y (or z) points. Note that you may have a tree (or chain) with 1 billion entries, but only a few may survive the cuts and will fit without problems in these arrays.

Using TTree::MakeClass

The `TTTree::Draw` method is convenient and easy to use; however it falls short if you need to do some programming with the variable.

For example, for plotting the masses of all oppositely charged pairs of tracks, you would need to write a program that loops over all events, finds all pairs of tracks, and calculates the required quantities. We have shown how to retrieve the data arrays from the branches of the tree in the previous section, and you could just write that program from scratch. Since this is a very common task, ROOT provides a utility that generates a skeleton class designed to loop over the entries of the tree. This is the `TTTree::MakeClass` method

We will now go through the steps of using `MakeClass` with a simplified example. The methods used here obviously work for much more complex event loop calculations.

These are our assumptions: we would like to do selective plotting and loop through each entry of the tree and tracks. We chose a simple example: we want to plot `fPx` of the first 100 tracks of each entry. We have a ROOT tree with a branch for each data member in the "Event" object. To build this file and tree follow the instructions on how to build the examples in `$ROOTSYS/test`.

Execute `Event` and instruct it to split the object with this command (from the UNIX command line).

```
> $ROOTSYS/test/Event 400 1 2 1
```

This creates an `Event.root` file with 400 events, compressed, split, and filled. See `$ROOTSYS/test/MainEvent.Cxx` for more info.

The person who designed the tree makes a shared library available to you, which defines the classes needed. In this case, the classes are `Event`, `EventHeader`, and `Track` and they are defined in the shared library `libEvent.so`. The designer also gives you the `Event.h` file to see the definition of the classes. You can locate `Event.h` in `$ROOTSYS/test`, and if you have not yet built `libEvent.so`, please see the instructions of how to build it. If you have already built it, you can now use it again.

Creating a Class with MakeClass

First, we load the shared library and open `Event.root`.

```
root[] .L libEvent.so
root[] TFile *f = new TFile("Event.root");
root[] f->ls();
TFile**      Event.root      TTree benchmark ROOT file
TFile*       Event.root      TTree benchmark ROOT file
KEY: TH1F    htime;1 Real-Time to write versus time
KEY: TTree   T;1           An example of a ROOT tree
```

We can see there is a tree "T", and just to verify that we are working with the correct one, we print the tree, which will show us the header and branches.

```
root[] T->Print();
```

From the output of print we can see that the tree has one branch for each data member of `Event`, `Track`, and `EventHeader`.

Now we can use `TTree::MakeClass` on our tree "T". `MakeClass` takes one parameter, a string containing the name of the class to be made.

In the command below, the name of our class will be "MyClass".

```
root[] T->MakeClass("MyClass")
Files: MyClass.h and MyClass.C generated from Tree: T
```

CINT informs us that it has created two files. `MyClass.h` contains the class definition and `MyClass.C` contains the `MyClass::Loop` method. `MyClass` has more methods than just `Loop`. The other methods are: a constructor, a destructor, `GetEntry`, `LoadTree`, `Notify`, and `Show`. The implementations of these methods are in the `.h` file. This division of methods was done intentionally. The `.C` file is kept as short as possible, and contains only code that is intended for you to customize. The `.h` file contains all the other methods.

It is clear that you want to be as independent as possible of the header file (i.e. `MyClass.h`) generated by `MakeClass`. The solution is to implement a derived class, for example `MyRealClass` deriving from `MyClass` such that a change in your `Tree` or regeneration of `MyClass.h` does not force you to change `MyRealClass.h`. You can imagine deriving several classes from `MyClass.h`, each with a specific algorithm.

To start with, it helps to understand both files, so let's start with `MyClass.h` and the class definition:

MyClass.h

```
class MyClass {
public :
  //pointer to the analyzed TTree or TChain
  TTree      *fChain;
  //current Tree number in a TChain
  Int_t      fCurrent;
  //Declaration of leaves types
  UInt_t     fUniqueID;
  UInt_t     fBits;
  Char_t     fType[20];
  Int_t      fNtrack;
  Int_t      fNseg;
  Int_t      fNvertex;
  UInt_t     fFlag;
  Float_t    fTemperature;
  Int_t      fEvtHdr_fEvtNum;
}
```

//continued..

```

//List of branches
TBranch      *b_fUniqueID;
TBranch      *b_fBits;
TBranch      *b_fType;
TBranch      *b_fNtrack;
TBranch      *b_fNseg;
TBranch      *b_fNvertex;
TBranch      *b_fFlag;
TBranch      *b_fTemperature;
TBranch      *b_fEvtHdr_fEvtNum;
...
      MyClass(TTree *tree=0);
      ~MyClass();
      Int_t Cut(Int_t entry);
      Int_t GetEntry(Int_t entry);
      Int_t LoadTree(Int_t entry);
      void Init(TTree *tree);
      void Loop();
      Bool_t Notify();
      void Show(Int_t entry = -1);
};

```

We can see data members in the generated class. The first data member is `fChain`. Once this class is instantiated, `fChain` will point to the original tree or chain this class was made from. In our case, this is "T" in "Event.root". If the class is instantiated with a tree as a parameter to the constructor, `fChain` will point to the tree named in the parameter.

Next is `fCurrent`, which is also a pointer to the current tree/chain. Its role is only relevant when we have multiple trees chained together in a `TChain`.

The class definition shows us that this tree has one branch and one leaf per data member.

The methods of `MyClass` are:

- `MyClass(TTree *tree=0)` : This constructor has an optional tree for a parameter. If you pass a tree, `MyClass` will use it rather than the tree from which it was created.
- `void Init(TTree *tree)` : `Init` is called by the constructor to initialize the tree for reading. It associates each branch with the corresponding leaf data member.
- `~MyClass()` : This is the destructor, nothing special.
- `Int_t GetEntry(Int_t entry)` : This loads the class with the entry specified. Once you have executed `GetEntry`, the leaf data members in `MyClass` are set to the values of the entry. For example, `GetEntry(12)` loads the 13th event into the event data member of `MyClass` (note that the first entry is 0).
`GetEntry` returns the number of bytes read from the file. In case the same entry is read twice, `ROOT` does not have to do any I/O. In this case `GetEntry` returns 1. It does not return 0, because many people assume a return of 0 means an error has occurred while reading.
- `Int_t LoadTree(Int_t entry)` and `void Notify()` :
These two methods are related to chains. `LoadTree` will load the tree containing the specified entry from a chain of trees. `Notify` is called by `LoadTree` to adjust the branch addresses.
- `void Loop()` : This is the skeleton method that loops through each entry of the tree. This is interesting to us, because we will need to customize it for our analysis.

MyClass.C

`MyClass::Loop` consists of a for-loop calling `GetEntry` for each entry. In the template, the numbers of bytes are added up, but it does nothing else. If we were to execute it now, there would be no output.

```
void MyClass::Loop()
{
  if (fChain == 0) return;
  Int_t nentries = fChain->GetEntries();

  Int_t nbytes = 0, nb = 0;
  for (Int_t jentry=0; jentry<nentries;jentry++) {
    Int_t ientry = LoadTree(jentry);
    // in case of a TChain, ientry is the entry number
    // in the current file
    nb = fChain->GetEntry(jentry);   nbytes += nb;
    // if (Cut(ientry) < 0) continue;
  }
}
```

At the beginning of the file are instructions about reading selected branches. They are not reprinted here, but please read them from your own file

Modifying MyClass::Loop

Lets continue with the goal of going through the first 100 tracks of each entry and plot `Px`. To do this we change the `Loop` method.

```
...
if (fChain == 0) return;
Int_t nentries = fChain->GetEntries();
TH1F *myHisto = new TH1F("myHisto","fPx", 100, -5,5);
TH1F *smallHisto = new TH1F("small","fPx", 100, -5,5);
...
```

In the for-loop, we need to add another for-loop to go over all the tracks.
In the outer for-loop, we get the entry and the number of tracks.
In the inner for-loop, we fill the large histogram (`myHisto`) with all tracks and the small histogram (`smallHisto`) with the track if it is in the first 100.

```
...
for (Int_t jentry=0; jentry<nentries;jentry++) {
  GetEntry(jentry);
  for (Int_t j = 0; j < 100; j++){
    myHisto->Fill(fTracks_fPx[j]);
    if (j < 100){
      smallHisto->Fill(fTracks_fPx[j]);
    }
  }
}
...
```

Outside of the for-loop, we draw both histograms on the same canvas.

```
...
myHisto->Draw();
smallHisto->Draw("Same");
...
```

Save these changes to `MyClass.C` and start a fresh root session. We will now load `MyClass` and experiment with its methods.

Loading MyClass

The first step is to load the library and the class file. Then we can instantiate a `MyClass` object.

```
root[] .L libEvent.so
root[] .L MyClass.C
root[] MyClass m
```

Now we can get a specific entry and populate the event leaf. In the code snippet below, we get entry 0, and print the number of tracks (594). Then we get entry 1 and print the number of tracks (597).

```
root[] m.GetEntry(0)
(int)57503
root[] m.fNtrack()
(Int_t)594
root[] m.GetEntry(1)
(int)48045
root[] m.fNtrack()
(Int_t)597
```

Now we can call the `Loop` method, which will build and display the two histograms.

```
root[] m.Loop()
```

You should now see a canvas that looks like this.

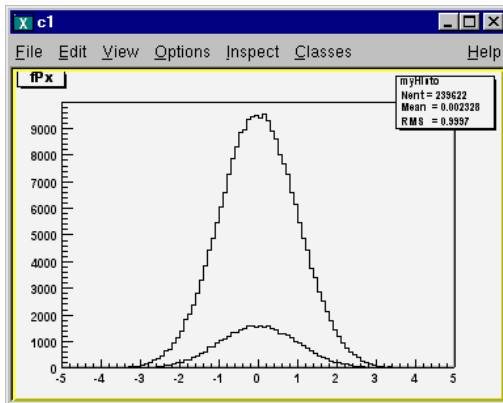

To conclude the discussion on `MakeClass` let's list the steps that got us here.

- Call `TTree::MakeClass`, which automatically creates a class to loop over the tree.
- Modify the `MyClass::Loop()` method in `MyClass.C` to fit your task.
- Load and instantiate `MyClass`, and run `MyClass::Loop()`.

Using TTree::MakeSelector

With a `TTree` we can make a selector and use it to process a limited set of entries. This is especially important in a parallel processing configuration where the analysis is distributed over several processors and we can specify which entries to send to each processor. The `TTree::Process` method is used to specify the selector and the entries.

Before we can use `TTree::Process` we need to make a selector. We can call the `TTree::MakeSelector` method. It creates two files similar to `TTree::MakeClass`.

In the resulting files is a class that is a descendent of `TSelector` and implements the following methods:

- `TSelector::Begin`: This function is called every time a loop over the tree starts. This is a convenient place to create your histograms.
- `TSelector::Notify()`: This function is called at the first entry of a new tree in a chain.
- `TSelector::ProcessCut`: This function is called at the beginning of each entry to return a flag true if the entry must be analyzed.
- `TSelector::ProcessFill`: This function is called in the entry loop for all entries accepted by `Select`.
- `TSelector::Terminate`: This function is called at the end of a loop on a `TTree`. This is a convenient place to draw and fit your histograms.

The `TSelector`, unlike the resulting class from `MakeClass`, separates the processing into a `ProcessCut` and `ProcessFill`, so that we can limit reading the branches to the ones we need.

To create a selector call:

```
root[] T->MakeSelector("MySelector");
```

Where `T` is the `TTree` and `MySelector` is the name of created class and the name of the `.h` and `.C` files.

The resulting `TSelector` is the argument to `TTree::Process`. The argument can be the file name or a pointer to the selector object.

```
root[] T->Process("MySelector.C", "", 1000, 100);
```

This call will interpret the class defined in `MySelector.C` and process 1000 entries beginning with entry 100. The file name can be appended with a "+" or a "++" to use `ACLiC`.

```
root[] T->Process("MySelector.C++", "", 1000, 100);
```

When appending a "++", the class will be compiled and dynamically loaded.

```
root[] T->Process("MySelector.C+", "", 1000, 100);
```

When appending a "+", the class will also be compiled and dynamically loaded. When it is called again, it recompiles only if the macro (`MySelector.C`) has changed since it was compiled last. If not it loads the existing library.

`TTree::Process` is aware of `PROOF`, `ROOT` parallel processing facility. If `PROOF` is setup, it divides the processing amongst the slave CPUs.

Performance Benchmarks

The program `$ROOTSYS/test/bench.cxx` compares the I/O performance of STL vectors to the `ROOT` native `TClonesArrays` collection class. It creates trees with and without compression for the following cases: `vector<THit>`, `vector<THit*>`, `TClonesArray(TObjHit)` not split `TClonesArray(TObjHit)` split.

The next graphs show the two columns on the right which represent the split and non-split `TClonesArray`, are significantly lower than the vectors. The most significant difference is in reading a file without compression.

The file size with compression, write times with and without compression and the read times with and without compression all favor the `TClonesArray`.

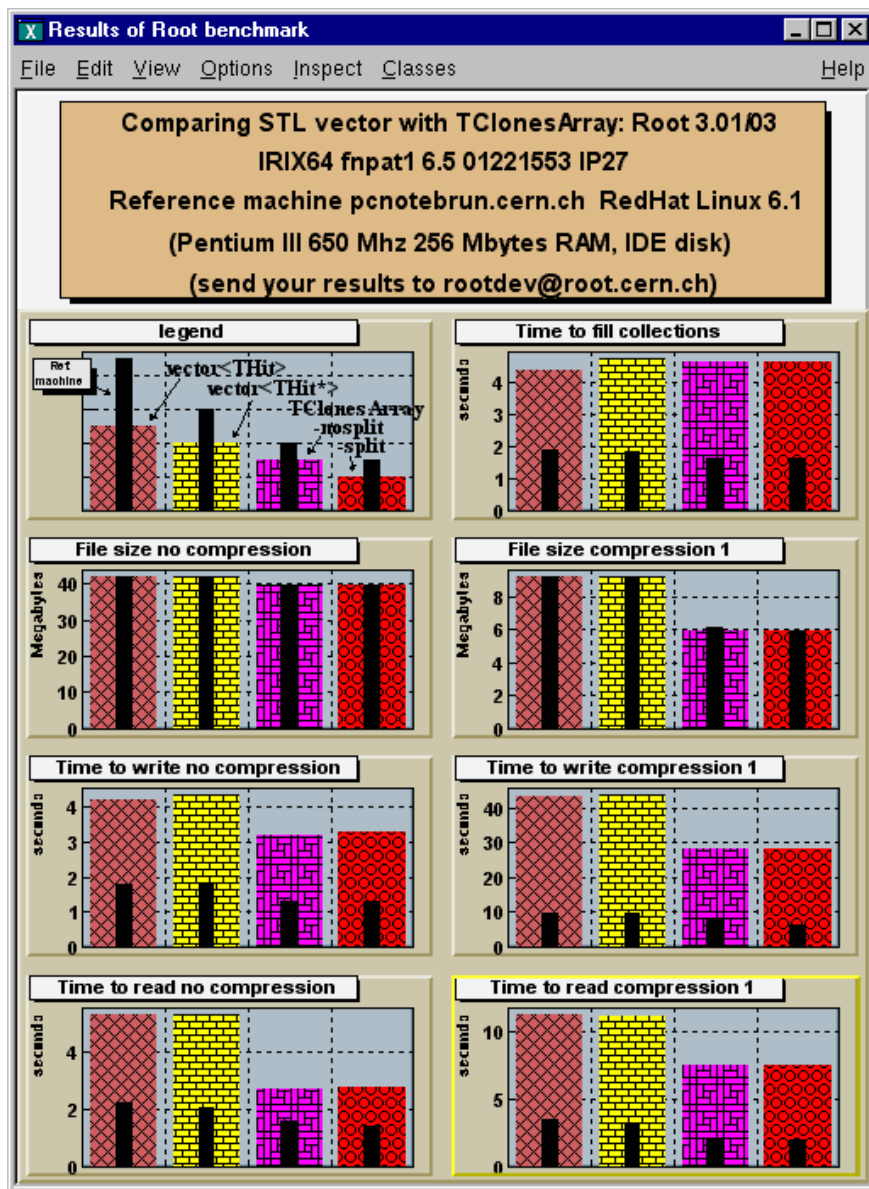

Impact of Compression on I/O

This benchmark illustrates the pros and cons of the compression option. We recommend using compression when the time spent in I/O is small compared to the total processing time. In this case, if the I/O operation is increased by a factor of 5 it is still a small percentage of the total time and it may very well save a factor of 10 on disk space. On the other hand if the time spend on I/O is large, compression may slow down the program's performance. The standard test program `$ROOTSYS/test/Event` was used in various configurations with 400 events. The data file contains a **TTree**. The program was invoked with:

```
Event 400 comp split
```

- `comp = 0` means: no compression at all.
- `comp = 1` means: compress everything if `split = 0`.
- `comp = 1` means: compress only the tree branches with integers if `split = 1`.
- `comp = 2` means: compress everything if `split=1`.
- `split = 0` : the full event is serialized into one single buffer.
- `split = 1` : the event is split into branches. One branch for each data member of the Event class. The list of tracks (a `TClonesArray`) has the data members of the Track class also split into individual buffers.

These tests were run on Pentium III CPU with 650 MHz.

Event Parameters	File Size	Total Time to Write (MB/sec)	Effective Time to Write (MB/sec)	Total Time to Read All (MB/sec)	Total Time to Read Sample (MB/sec)
Comp = 0 Split = 1	19.75 MB	6.84 s. (2.8 MB/s)	3.56 s. (5.4 MB/s)	0.79 s. (24.2 MB/s)	0.79 s. (24.2 MB/s)
Comp = 1 Split = 1	17.73 MB	6.44 s. (3.0 MB/s)	4.02 s. (4.8 MB/s)	0.90 s. (21.3 MB/s)	0.90 s. (21.3 MB/s)
Comp = 2 Split = 1	13.78 MB	11.34 s. (1.7 MB/s)	9.51 s. (2.0 MB/s)	2.17 s. (8.8 MB/s)	2.17 s. (8.8 MB/s)

The **Total Time** is the real time in seconds to run the program.

Effective time is the real time minus the time spent in non I/O operations (essentially the random number generator). The program `Event` generates in average 600 tracks per event. Each track has 17 data members. The read benchmark runs in the interactive version of ROOT. The **Total Time to read All** is the real time reported by the execution of the script `&ROOTSYS/test/eventa`. We did not correct this time for the overhead coming from the interpreter itself.

The **Total time to read sample** is the execution time of the script `&ROOTSYS/test/eventb`. This script loops on all events. For each event, the branch containing the number of tracks is read. In case the number of tracks is less than 585, the full event is read in memory. This test is obviously not possible in non-split mode. In non-split mode, the full event must be read in memory.

The times reported in the table correspond to complete I/O operations necessary to deal with **machine independent binary files**. On **Linux**, this also includes byte-swapping operations. The ROOT file allows for direct access to any event in the file and also direct access to any part of an event when `split=1`.

Note also that the uncompressed file generated with `split=0` is 48.7 Mbytes and only 47.17 Mbytes for the option `split=1`. The difference in size is due to the object identification mechanism overhead when the event is written to a single buffer. This overhead does not exist in split mode because the branch buffers are optimized for homogeneous data types.

You can run the test programs on your architecture. The program `Event` will report the write performance. You can measure the read performance by executing the scripts `eventa` and `eventb`. The performance depends not only of the processor type, but also of the disk devices (local, NFS, AFS, etc.).

Chains

A `TChain` object is a list of ROOT files containing the same tree. As an example, assume we have three files called `file1.root`, `file2.root`, `file3.root`. Each file contains one tree called "T". We can create a chain with the following statements:

```
TChain chain("T"); // name of the tree is the argument
chain.Add("file1.root");
chain.Add("file2.root");
chain.Add("file3.root");
```

The name of the `TChain` will be the same as the name of the tree; in this case it will be "T". Note that two objects can have the same name as long as they are not histograms in the same directory, because there, the histogram names are used to build a hash table. The class `TChain` is derived from the class `TTree`.

For example, to generate a histogram corresponding to the attribute "x" in tree "T" by processing sequentially the three files of this chain, we can use the `TChain::Draw` method.

```
chain.Draw("x");
```

When using a `TChain`, the branch address(es) must be set with:

```
chain.SetBranchAddress(branchname,...) // use this for TChain
```

rather than:

```
branch->SetAddress(...); // this will not work
```

The second form returns the pointer to the branch of the current `TTree` in the chain, typically the first one. The information is lost when the next `TTree` is loaded.

The following statements illustrate how to set the address of the object to be read and how to loop on all events of all files of the chain.

```
{
    TChain chain("T"); // create the chain with tree "T"
    chain.Add("file1.root"); // add the files
    chain.Add("file2.root");
    chain.Add("file3.root");

    TH1F *hnseg = new TH1F("hnseg",
                          "Number of segments for selected tracks",5000,0,5000);

    // create an object before setting the branch address
    Event *event = new Event();
    // Specify the address where to read the event object
    chain.SetBranchAddress("event", &event);

    // Start main loop on all events In case you want to read only a few
    // branches, use TChain::SetBranchStatus to activate a branch.
    Int_t nevent = chain.GetEntries();
    for (Int_t i=0;i<nevent;i++) {
        // read complete accepted event in memory
        chain.GetEvent(i);
        // Fill histogram with number of segments
        hnseg->Fill(event->GetNseg());
    }

    // Draw the histogram
    hnseg->Draw();
}
```

TChain::AddFriend

A `TChain` has a list of friends similar to a tree (see `TTree::AddFriend`). You can add a friend to a chain with the `TChain::AddFriend` method. You can retrieve the list of friends with `TChain::GetListOfFriends`.

This example has four chains each has 20 ROOT trees from 20 ROOT files.

```
TChain ch("t"); // a chain with 20 trees from 20 files
TChain ch1("t1");
TChain ch2("t2");
TChain ch3("t3");
```

Now we can add the friends to the first chain.

```
ch.AddFriend("t1")
ch.AddFriend("t2")
ch.AddFriend("t3")
```

The parameter is the name of friend chain (the name of a chain is always the name of the tree from which it was created).

The original chain has access to all variables in its friends. We can use the `TChain::Draw` method as if the values in the friends were in the original chain.

To specify the chain to use in the `Draw` method, use the syntax:

```
<chainname>.<branchname>.<varname>
```

If the variable name is enough to uniquely identify the variable, you can leave out the chain and/or branch name.

For example, this generates a 3-d scatter plot of variable "var" in the `TChain ch` versus variable `v1` in `TChain t1` versus variable `v2` in `TChain t2`.

```
ch.Draw("var:t1.v1:t2.v2");
```

When a `TChain::Draw` is executed, an automatic call to `TTree::AddFriend` connects the trees in the chain. When a chain is deleted, its friend elements are also deleted.

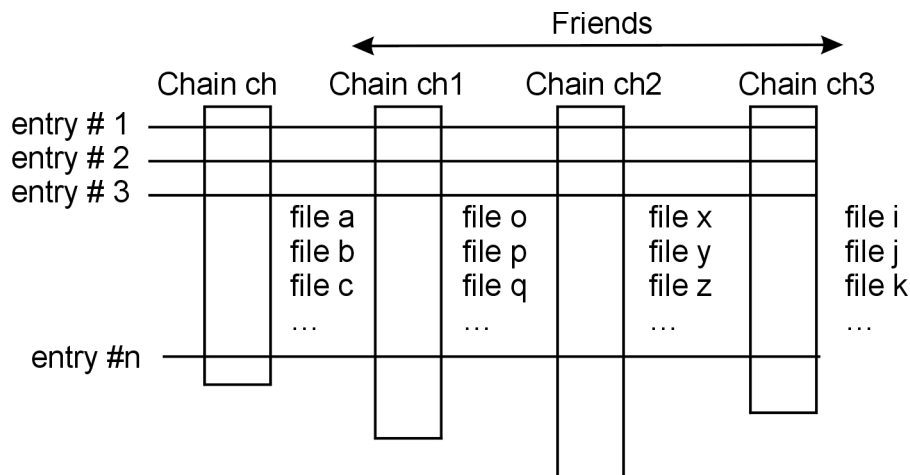

The number of entries in the friend must be equal or greater to the number of entries of the original chain. If the friend has fewer entries a warning is given and the resulting histogram will have missing entries.

For additional information see `TTree::AddFriends`. A full example of a tree and friends is in Example #3 (`$ROOTSYS/tutorials/tree3.c`) in the Tree section above.

13 Adding a Class

The Role of TObject

The light-weight `TObject` class provides the default behavior and protocol for the objects in the ROOT system. Specifically, it is the primary interface to classes providing object I/O, error handling, inspection, introspection, and drawing. The interface to this service is via abstract classes.

Introspection, Reflection and Run Time Type Identification

Introspection, which is also referred to as reflection, or run time type identification (RTTI) is the ability of a class to reflect upon itself or to "look inside itself. ROOT implements reflection with the `TClass` class. It provides all the information about a class, a full description of data members and methods, including the comment field and the method parameter types. A class with the `ClassDef` macro has the ability to obtain a `TClass` with the `IsA` method.

```
TClass *cl = obj->IsA();
```

which returns a `TClass`. In addition an object can directly get the class name and the base classes with:

```
const char* name = obj->ClassName();
```

which returns a character string containing the class name. If the class is a descendent of `TObject`, you can check if an object inherits from a specific class, you can use the `InheritsFrom` method. This method returns `kTrue` if the object inherits from the specified class name or `TClass`.

```
Bool_t b = obj->InheritsFrom("TLine");  
Bool_t b = obj->InheritsFrom(TLine::Class());
```

ROOT and `CINT` rely on reflection and the class dictionary to identify the type of a variable at run time. With `TObject` inheritance come some methods that use Introspection to help you see the data in the object or class. For instance:

```
obj->Dump();           // lists all data members and their current value  
obj->Inspect();        // opens a window to browser data members at all levels  
obj->DrawClass();      // Draws the class inheritance tree
```

For an example of `obj->Inspect` see "[Inspecting ROOT Objects](#)" in the `CINT` chapter.

Collections

To store an object in a ROOT collection, it must be a descendent of `TObject`. This is convenient if you want to store objects of different classes in the same collection and execute the method of the same name on all members of the collection. For example the list of graphics primitives are in a ROOT collection called `TList`. When the canvas is

drawn the `Paint` method is executed on the entire collection. Each member may be a different class, and if the `Paint` method is not implemented, `TObject::Paint` will be executed.

Input/Output

The `TObject::Write` method is the interface to the ROOT I/O system. It streams the object into a buffer using the `Streamer` method. It supports cycle numbers and automatic schema evolution (see the chapter on [Input/Output](#)).

Paint/Draw

These two graphics methods are defaults, their implementation in `TObject` does not use the graphics subsystem. The `TObject::Draw` method is simply a call to `AppendPad`. The `Paint` method is empty. The default is provided so that one can call `Paint` in a collection.

GetDrawOption

This method returns the draw option that was used when the object was drawn on the canvas. This is especially relevant with histograms and graphs.

Clone/DrawClone

Two useful methods are `Clone` and `DrawClone`. The `Clone` method takes a snapshot of the object with the `Streamer` and creates a new object. The `DrawClone` method does the same thing and in addition draws the clone.

Browse

This method is called if the object is browse-able and is to be displayed in the object browser. For example the `TTree` implementation of `Browse`, calls the `Browse` method for each branch. The `TBranch::Browse` method displays the name of each leaf. For the object's `Browse` method to be called, the `IsFolder()` method must be overridden to return true. This does not mean it has to be a folder, it just means that it is browse-able.

SavePrimitive

This method is called by a canvas on its list of primitives, when the canvas is saved as a script. The purpose of `SavePrimitive` is to save a primitive as a C++ statement(s). Most ROOT classes implement the `SavePrimitive` method. It is recommended that the `SavePrimitive` is implemented in user defined classes if it is to be drawn on a canvas. Such that the command `TCanvas::SaveAs(Canvas.C)` will preserve the user-class object in the resulting script.

GetObjectInfo

This method is called when displaying the event status in a canvas. To show the event status window, select the `Options` menu and the `EventStatus` item. This method returns a string of information about the object at position (x, y). Every time the cursor moves, the object under the cursor executes the `GetObjectInfo` method. The string is then shown in the status bar. There is a default implementation in `TObject`, but it is typically overridden for classes that can report peculiarities for different cursor positions (for example the bin contents in a `TH1`).

IsFolder

By default an object inheriting from `TObject` is not brows-able, because `TObject::IsFolder()` returns `kFALSE`. To make a class browse-able, the `IsFolder`

method needs to be overridden to return `kTRUE`. In general, this method returns `kTRUE` if the object contains browse-able objects (like containers or lists of other objects).

Bit Masks and Unique ID

A `TObject` descendent inherits two data members: `fBits` and `fUniqueID`. `fBits` is 32-bit data member used with a bit mask to get object information. Bit 0–7 are reserved by `TObject`. The `kMustCleanup`, `kCanDelete` are used in `TObject`, these can be set by any object and should not be reused. These are the bits used in `TObject`:

```
enum EObjBits {
    kCanDelete      = BIT(0),    //if object in a list can be deleted
    kMustCleanup    = BIT(3),    //if object destructor must call
                                //RecursiveRemove()
    kCannotPick     = BIT(6),    //if object in a pad cannot be picked
    kInvalidObject  = BIT(13)   // if object ctor succeeded but
                                // object should not be used
};
```

The remaining 24 bits can be used by other classes. Make sure there is no overlap in any given hierarchy. For example `TClass` uses bit 12 and 13 `kClassSaved` and `kIgnoreTObjectStreamer` respectively.

The above bit 13 is set when an object could not be read from a ROOT file. It will check this bit and skip to the next object on the file. The `TObject` constructor initializes the `fBits` to zero depending if the object is created on the stack or allocated on the heap. When the object is created on the stack, the `kCanDelete` bit is set to false to protect from deleting objects on the stack. Of the status word the high 8 bits are reserved for system usage and the low 24 bits are user settable.

`fUniqueID` is a data member used to give a unique identification number to an object. It is initialized to zero by the `TObject` constructor. This data member is not used by ROOT.

The two data members (`fBits` and `fUniqueID`) are streamed out when writing an object to disk. If you do not use them you can save some space and time by specifying:

```
MyClass::Class()->IgnoreTObjectStreamer()
```

This sets a bit in the `TClass` object. If the file is compressed, the savings are minimal since most values are zero; however, it saves some space when the file is not compressed. A call to `IgnoreObjectStreamer` also prevents the creation of two additional branches when splitting the object. If left alone, two branches called `fBits` and `fUniqueID` will appear.

Motivation

If you want to integrate and use your classes with ROOT, to enjoy features like, extensive RTTI (Run Time Type Information) and ROOT object I/O and inspection, you have to add the following line to your class header files:

```
ClassDef(className,ClassVersionID) //The class title
```

For example in `TLine.h` we have:

```
ClassDef(TLine,1) //A line segment
```

The `ClassVersionID` is used by the ROOT I/O system. It is written on the output stream and during reading you can check this version ID and take appropriate action depending on the value of the ID (see the section on Streamers in the Chapter [Input/Output](#)). Every time you change the data members of a class, you should increase its `ClassVersionID` by one. The `ClassVersionID` should be `>=1`. Set `ClassVersionID=0` in case you don't need object I/O. Similarly, in your implementation file you must add the statement:

```
ClassImp (ClassName)
```

For example in `TLine.cxx`:

```
ClassImp (TLine)
```

Note that you **MUST** provide a default constructor for your classes, i.e. a constructor with zero parameters or with one or more parameters all with default values in case you want to use object I/O. If not you will get a compile time error. The `ClassDef` and `ClassImp` macros are necessary to link your classes to the dictionary generated by CINT. The `ClassDef` and `ClassImp` macros are defined in the file `Rtypes.h`. This file is referenced by all ROOT include files, so you will automatically get them if you use a ROOT include file.

Template Support

ROOT provides `ClassDef` and `ClassImp` macros for classes with two and three template arguments. The macros are: `ClassDefT`, `ClassDef2T2`, `ClassDef3T2` and `ClassImpT`, `ClassImp2T`, `ClassImp3T`. `ClassDefT` is independent of the number of template arguments. For templates the `ClassImp` must be in the header file. When you use templates in principle all the code is defined in the header. Then when a special "instantiation" is needed the compiler takes the code in the header and generates the real code (i.e. replaces the `T` by `int`, where `T` was the template argument). So for template classes it is normal to put the `ClassImp` in the header. Here is an example of a header and `LinkDef` file:

```
// in header file MyClass.h
template <typename T> class MyClass1 {
private:
    T fA;
    ...
public:
    ...
    ClassDefT(MyClass1,1)
};
ClassDefT2(MyClass1,T)
ClassImpT(MyClass1,T)

template <typename T1, typename T2> class MyClass2 {
private:
    T1 fA;
    T2 fB;
public:
    ...
    ClassDefT(MyClass2,1)
};
ClassDef2T2(MyClass2,T1,T2)
ClassImp2T(MyClass2,T1,T2)

template <typename T1, typename T2, typename T3> class MyClass3 {
private:
    T1 fA;
    T2 fB;
    T3 fC;
    ...
public:
    ...
    ClassDefT(MyClass3,1)
};
ClassDef3T2(MyClass3,T1,T2,T3)
ClassImp3T(MyClass3,T1,T2,T3)
```



```

// A LinkDef.h file with all the explicit template
// instances that will be needed at link time
#ifdef __CINT__

#pragma link off all globals;
#pragma link off all classes;
#pragma link off all functions;

#pragma link C++ class MyClass1<float>+;
#pragma link C++ class MyClass1<double>+;
#pragma link C++ class MyClass2<float,int>+;
#pragma link C++ class MyClass2<float,double>+;
#pragma link C++ class MyClass3<float,int,TObject*>+;
#pragma link C++ class MyClass3<float,TEvent*,TObject*>+;

#endif

```

The Default Constructor

ROOT object I/O requires every class to have a default constructor. This default constructor is called whenever an object is being read from a ROOT database. Be sure that you don't allocate any space for embedded pointer objects in the default constructor. This space will be lost (memory leak) while reading in the object. For example:

```

class T49Event : public TObject {
private:
    Int_t      fId;
    TCollection *fTracks;
    ...

public:
    // Error space for TList pointer will be lost
    T49Event() { fId = 0; fTrack = new TList; }

    // Correct default initialization of pointer
    T49Event() { fId = 0; fTrack = 0; }
    ...
};

```

The memory will be lost because during reading of the object the pointer will be set to the object it was pointing to at the time the object was written.

Create the **fTrack** list when you need it, e.g. when you start filling the list or in a **not-default** constructor.

```

...
if (!fTrack) fTrack = new TList;
...

```

rootcint: The CINT Dictionary Generator

In the following example we walk through the steps necessary to generate a dictionary, I/O, and inspect member functions. Let's start with a `TEvent` class, which contains a collection of `TTracks`:

```
#ifndef __TEvent__
#define __TEvent__

#include "TObject.h"

class TCollection;
class TTrack;

class TEvent : public TObject {

private:
    Int_t      fId;           // event sequential id
    Float_t    fTotalMom;    // total momentum
    TCollection *fTracks;    // collection of tracks

public:
    TEvent() { fId = 0; fTracks = 0; }
    TEvent(Int_t id);
    ~TEvent();

    void      AddTrack(TTrack *t);
    Int_t     GetId() const { return fId; }
    Int_t     GetNoTracks() const;
    void      Print(Option_t *opt="");
    Float_t   TotalMomentum();

    ClassDef (TEvent,1)      //Simple event class
};
```

The things to notice in these header files are:

- The usage of the `ClassDef` macro
- The default constructors of the `TEvent` and `TTrack` classes
- Comments to describe the data members and the comment after the `ClassDef` macro to describe the class

These classes are intended for you to create an event object with a certain id, and then add tracks to it. The track objects have a pointer to their event. This shows that the I/O system correctly handles circular references.

And the TTrack.h header:

```
#ifndef __TTrack__
#define __TTrack__

#include "TObject.h"

class TEvent;

class TTrack : public TObject {

private:
    Int_t      fId;          //track sequential id
    TEvent     *fEvent;     //event to which track belongs
    Float_t    fPx;        //x part of track momentum
    Float_t    fPy;        //y part of track momentum
    Float_t    fPz;        //z part of track momentum

public:
    TTrack() { fId = 0; fEvent = 0; fPx = fPy = fPz = 0; }
    TTrack(Int_t id, Event *ev, Float_t px,Float_t py,Float_t pz);

    Float_t    Momentum() const;
    TEvent     *GetEvent() const { return fEvent; }
    void       Print(Option_t *opt="");

    ClassDef (TTrack,1) //Simple track class
};

#endif
```

Next is the implementation of these two classes.

Event.cxx:

```
#include <iostream.h>

#include "TOrdCollection.h"
#include "TEvent.h"
#include "TTrack.h"

ClassImp(TEvent)

...
```

Track.cxx:

```
#include <iostream.h>

#include "TMath.h"
#include "Track.h"
#include "Event.h"

ClassImp(TTrack)

...
```

Now using `rootcint` we can generate the dictionary file.

Make sure you use a unique filename, because `rootcint` appends it to the name of static function (`G__cpp_reset_tabableeventdict()` and `G__set_cpp_environmenteventdict()`).

```
rootcint eventdict.cxx -c TEvent.h TTrack.h
```

Looking in the file `eventdict.C` we can see, besides the many member function calling stubs (used internally by the interpreter), the `Streamer()` and `ShowMembers()` methods for the two classes. `Streamer()` is used to stream an object to/from a **TBuffer** and `ShowMembers()` is used by the `Dump()` and `Inspect()` methods of **TObject**.

Here is the `TEvent::Streamer` method:

```
void TEvent::Streamer(TBuffer &R__b)
{
    // Stream an object of class TEvent.
    if (R__b.IsReading()) {
        Version_t R__v = R__b.ReadVersion();
        TObject::(R__b);
        R__b >> fId;
        R__b >> fTotalMom;
        R__b >> fTracks;
    } else {
        R__b.WriteVersion(TEvent::IsA());
        TObject::Streamer(R__b);
        R__b << fId;
        R__b << fTotalMom;
        R__b << fTracks;
    }
}
```

The **TBuffer** class overloads the `operator<<()` and `operator>>()` for all basic types and for pointers to objects. These operators write and read from the buffer and take care of any needed byte swapping to make the buffer machine independent. During writing the **TBuffer** keeps track of the objects that have been written and multiple references to the same object are replaced by an index. In addition, the object's class information is stored.

TEvent and **TTracks** need manual intervention. Cut and paste the generated `Streamer()` from the `eventdict.C` into the class' source file and modify as needed (e.g. add counter for array of basic types) and disable the generation of the `Streamer()` when using the `LinkDef.h` file for next execution of `rootcint`.

In case you don't want to read or write this class (no I/O) you can tell `rootcint` to generate a dummy `Streamer()` by changing this line in the source file:

```
ClassDef(TEvent,0)
```

If you want to prevent the generation of `Streamer()`, see the next chapter "Adding a Class with a Shared Library".

Adding a Class with a Shared Library

Step 1:

Define your own class in `SClass.h` and implement it in `SClass.cxx`. You must provide a default constructor for your class.

```
#include <iostream.h>
#include "TObject.h"
class SClass : public TObject {
private:
    Float_t    fX;           //x position in centimeters
    Float_t    fY;           //y position in centimeters
    Int_t      fTempValue;   //! temporary state value
public:
    SClass()                { fX = fY = -1; }
    void Print() const;
    void SetX(float x) { fX = x; }
    void SetY(float y) { fY = y; }

    ClassDef(SClass, 1)
};
```

Step 2:

Add a call to the `ClassDef` macro to at the end of the class definition (i.e. in the `SClass.h` file). `ClassDef(SClass,1)`. Add a call to the `ClassImp` macro in the implementation file (`SClass.cxx`): `ClassImp(SClass)`.

`SClass.cxx`:

```
#include "SClass.h"
ClassImp(SClass);
void SClass::Print() const {
    cout << "fX = " << fX << ", fY = " << fY << endl;
}
```

You can add a class without using the `ClassDef` and `ClassImp` macros, however you will be limited. Specifically the object I/O features of ROOT will not be available to you for these classes (see the chapter "[CINT the C++ Interpreter](#)"). The `ShowMembers()` and `Streamer()` method, as well as the `>>` operator overloads, are implemented only if you use `ClassDef` and `ClassImp`. See <http://root.cern.ch/root/html/Rtypes.h> for the definition of `ClassDef` and `ClassImp`.

To exclude a data member from the `Streamer`, add a `!` as the first character in the comments of the field:

```
Int_t      fTempValue; //! temporary state value
```

The LinkDef.h File

Step 3:

The `LinkDef.h` file tells `rootcint` for which classes to generate the method interface stubs.

```
#ifdef __CINT__
#pragma link off all globals;
#pragma link off all classes;
#pragma link off all functions;
#pragma link C++ class SClass;
#endif
```

Three options can trail the class name:

- **-** : tells `rootcint` **not** to generate the `Streamer()` method for this class. This is necessary for those classes that need a customized `Streamer()` method.

```
#pragma link C++ class SClass-; // no streamer
```

- **!** : tells `rootcint` **not** to generate the `operator>>(TBuffer &b, MyClass *&obj)` method for this class. This is necessary to be able to write pointers to objects of classes not inheriting from `TObject`.

```
#pragma link C++ class SClass!; // no >> operator
// or
#pragma link C++ class SClass-!; // no Streamer no >> operator
```

- **+** : in ROOT version 1 and 2 tells `rootcint` to generate a `Streamer()` with extra byte count information. This adds an integer to each object in the output buffer, but it allows for powerful error correction in case a `Streamer()` method is out of sync with data in the file. The `+` option is mutual exclusive with both the `-` and `!` options.

IMPORTANT NOTE: In ROOT Version 3, a "+" after the class name tells `rootcint` to use the new I/O system. The byte count check is always added.

```
#pragma link C++ class SClass+; // add byte count
```

For information on `Streamers` see the section on [Streamers](#) in the Input/Output chapter. To get help on `rootcint` type on the UNIX command line:
`rootcint -?.`

The Order Matters

When using template classes, the order of the `pragma` statements matters. For example, here is a template class `Tmpl` and a normal class `Norm` which holds a specialized instance of a `Tmpl`:

```
class Norm {
private:
    Tmpl<int>* fIntTmpl;
public:
    ...
};
```

Then in `Linkdef.h` the `pragma` statements must be ordered by listing all specializations before any classes which need them:

```
// Correct Linkdef.h ordering
...
#pragma link C++ class Tmpl<int>;
#pragma link C++ class Norm;
...
```

And not vice versa:

```
// Bad Linkdef.h ordering
...
#pragma link C++ class Norm;
#pragma link C++ class Tmpl<int>;
...
```

In this later case, `rootcint` generates `Norm::Streamer()` which makes reference to `Tmpl<int>::Streamer()`. Then `rootcint` gets to process `Tmpl<int>` and generates a specialized `Tmpl<int>::Streamer()` function. The problem is, when the compiler

finds the first `Tmpl<int>::Streamer()`, it will instantiate it. But, later in the file it finds the specialized version that `rootcint` generated. This causes the error. However, if the `Linkdef.h` order is reversed then `rootcint` can generate the specialized `Tmpl<int>::Streamer()` before it is needed (and thus never instantiated by the compiler).

Step 4: Compile the class using the Makefile. In the Makefile call `rootcint` to make the dictionary for the class. Call it `SClassDict.cxx`. The `rootcint` utility generates the methods `Streamer()`, `TBuffer &operator>>()` and `ShowMembers()` for ROOT classes.

For more information on `rootcint` see the `$ROOTSYS/test` directory Makefile, `Event.cxx`, and `Event.h` for an example, or follow this link:
<http://root.cern.ch/root/RootCintMan.html>

```
gmake -f Makefile
```

Load the shared library:

```
root[] .L SClass.so
root[] SClass *sc = new SClass()
root[] TFile *f = new TFile("Afile.root","UPDATE");
root[] sc->Write();
```

Adding a Class with ACLiC

Step 1: Define your class

```
#include "TObject.h"
// define the ABC class and make it inherit
// from TObject so that we can write ABC to a ROOT file
class ABC : public TObject {

public:
    Float_t a, b, c, p;
    ABC() : a(0), b(0), c(0), p(0){};

    // Define the class for the cint dictionary
    ClassDef(ABC,1)
};

// Call the ClassImp macro to give the ABC class RTTI
// and full I/O capabilities.

#if !defined(__CINT__)
    ClassImp(ABC);
#endif
```

Step 2: Load the ABC class in the script.

```
// Check if ABC is already loaded
if (!TClassTable::GetDict("ABC")) {
    gROOT->Macro("ABCClass.C++");
}

// Use the Class
ABC *v = new ABC;
v->p = (sqrt((v->a * v->a) + (v->b * v->b) + (v->c * v->c)));
```

14 Collection Classes

Collections are a key feature of the ROOT system. Many, if not most, of the applications you write will use collections. If you have used parameterized C++ collections or polymorphic collections before, some of this material will be review. However, much of this chapter covers aspects of collections specific to the ROOT system. When you have read this chapter, you will know

- How to create instances of collections
- The difference between lists, arrays, hash tables, maps, etc.
- How to add and remove elements of a collection
- How to search a collection for a specific element
- How to access and modify collection elements
- How to iterate over a collection to access collection elements
- How to manage memory for collections and collection elements
- How collection elements are tested for equality (`IsEqual()`)
- How collection elements are compared (`Compare()`) in case of sorted collections
- How collection elements are hashed (`Hash()`) in hash tables

Understanding Collections

A collection is a group of related objects. You will find it easier to manage a large number of items as a collection. For example, a diagram editor might manage a collection of points and lines. A set of widgets for a graphical user interface can be placed in a collection. A geometrical model can be described by collections of shapes, materials and rotation matrices. Collections can themselves be placed in collections. Collections act as flexible alternatives to traditional data structures of computers science such as arrays, lists and trees.

General Characteristics

The ROOT collections are polymorphic containers that hold pointers to `TObjects`, so:

- They can only hold objects that inherit from `TObject`
- They return pointers to `TObjects`, that have to be cast back to the correct subclass

Collections are dynamic; they can grow in size as required.

Collections themselves are descendants of `TObject` so can themselves be held in collections. It is possible to nest one type of collection inside another to any level to produce structures of arbitrary complexity.

Collections don't own the objects they hold for the very good reason that the same object could be a member of more than one collection. Object ownership is important when it comes to deleting objects; if nobody owns the object it could end up as wasted memory (i.e. a memory leak) when no longer needed. If a collection is deleted, its objects are not. The user can force a collection to delete its objects, but that is the user's choice.

Determining the Class of Contained Objects

Most containers may hold heterogeneous collections of objects and then it is left to the user to correctly cast the `TObject` pointer to the right class. *Casting to the wrong class will give wrong results and may well crash the program!* So the user has to be very careful. Often a container only contains one class of objects, but if it really contains a mixture, it is possible to ask each object about its class using the `InheritsFrom()` method.

For example if `myObject` is a `TObject` pointer:

```
if (myObject->InheritsFrom("TParticle") {
    printf("myObject is a TParticle\n");
}
```

As the name suggests, this test works even if the object is a subclass of `TParticle`. The member function `IsA()` can be used instead of `InheritsFrom()` to make the test exact. The `InheritsFrom()` and `IsA()` methods use the extensive Run Time Type Information (RTTI) available via the `ROOT` meta classes.

Types of Collections

The `ROOT` system implements the following basic types of collections: unordered collections, ordered collections and sorted collections. This picture shows the inheritance hierarchy for the primary collection classes. All primary collection classes derive from the abstract base class `TCollection`.

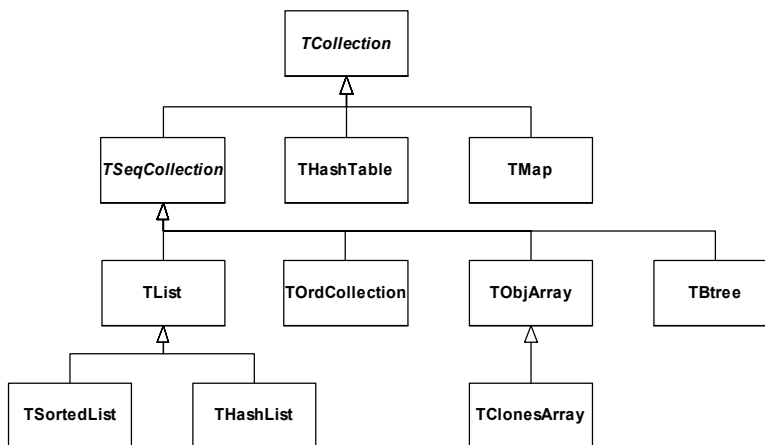

Ordered Collections (Sequences)

Sequences are collections that are externally ordered because they maintain internal elements according to the order in which they were added. The following sequences are available:

- `TList`
- `THashList`
- `TOrdCollection`
- `TObjArray`
- `TClonesArray`

The `TOrdCollection`, `TObjArray` as well as the `TClonesArray` can be sorted using their `Sort()` member function (if the stored items are sort able). Ordered collections all derive from the abstract base class `TSeqCollection`.

Sorted Collection

Sorted collections are ordered by an internal (automatic) sorting mechanism. The following sorted collections are available:

- **TSortedList**
- **TBtree**

The stored items must be sort able.

Unordered Collections

Unordered collections don't maintain the order in which the elements were added, i.e. when you iterate over an unordered collection, you are not likely to retrieve elements in the same order they were added to the collection. The following unordered collections are available:

- **THashTable**
- **TMap**

Iterators: Processing a Collection

The concept of processing all the members of a collection is generic, i.e. independent of any specific representation of a collection. To process each object in a collection one needs some type of cursor that is initialized and then steps over each member of the collection in turn. Collection objects could provide this service but there is a snag: as there is only one collection object per collection there would only be one cursor. Instead, to permit the use of as many cursors as required, they are made separate classes called iterator. For each collection class there is an associated iterator class that knows how to sequentially retrieve each member in turn. The relationship between a collection and its iterator is very close and may require that the iterator has full access to the collection (i.e. it is a friend class). In general iterator will be used via the **TIter** wrapper class.

For example:

- **TList** **TListIter**
- **TMap** **TMapIter**

Foundation Classes

All collections are based on the fundamental classes: **TCollection** and **TIterator**. They are so generic that it is not possible to create objects from them; they are only used as base classes for other classes (i.e. they are abstract base classes).

TCollection

The **TCollection** class provides the basic protocol (i.e. the minimum set of member functions) that all collection classes have to implement. These include:

- **Add()** Adds another object to the collection.
- **GetSize()** Returns the number of objects in the collection.
- **Clear()** Clears out the collection, but does not delete the removed objects.
- **Delete()** Clears out the collection and deletes the removed objects. This should only be used if the collection owns its objects (which are not normally the case).
- **FindObject()** Find an object given either its name or address.
- **MakeIterator()** Returns an iterator associated with the collection.
- **Remove()** Removes an object from the collection.

Coming back to the issue of object ownership. The code example below shows a class containing three lists, where the `fTracks` list is the owning collection and the other two

lists are used to store a sub-set of the track objects. In the destructor of the class the `Delete()` method is called for the owning collection to delete correctly all its track objects.

To delete the objects in the container do `'fTrack->Delete()'`. To delete the container itself do `'delete fTracks'`.

```
class TEvent : public TObject{
private:
    TList *fTracks; //list of all tracks
    TList *fVertex1; //subset of tracks part of vertex1
    TList *fVertex2; //subset of tracks part of vertex2
    ...
};

TEvent::~TEvent()
{
    fTracks->Delete();
    delete fTracks;
    delete fVertex1;
    delete fVertex2;
}
```

TIterator

The **TIterator** class defines the minimum set of member functions that all iterators must support. These include:

- `Next()` return the next member of the collection or 0 if no more members.
- `Reset()` reset the iterator so that `Next()` returns the first object.

A Collectable Class

By default, all objects of **TObject** derived classes can be stored in ROOT containers. However, the **TObject** class provides some member functions that allow you to tune the behavior of objects in containers. For example, by default two objects are considered equal if their pointers point to the same address. This might be too strict for some classes where equality is already achieved if some or all of the data members are equal. By overriding the following **TObject** member functions, you can change the behavior of objects in collections:

- `IsEqual()` is used by the `FindObject()` collection method. By default, `IsEqual()` compares the two object pointers.
- `Compare()` returns -1, 0 or 1 depending if the object is smaller, equal or larger than the other object. By default, a **TObject** has not a valid `Compare()` method.
- `IsSortable()` returns true if the class is sort able (i.e. if it has a valid `Compare()` method). By default, a **TObject** is not sort able.
- `Hash()` returns a hash value. It needs to be implemented if an object has to be stored in a collection using a hashing technique, like **THashTable**, **THashList** and **TMap**. By default, `Hash()` returns the address of the object. It is essential to choose a good hash function.

The example below shows how to use and override these member functions.

```
// TObjNum is a simple container for an integer.
class TObjNum : public TObject {
private:
    int num;

public:
    TObjNum(int i = 0) : num(i) { }
    ~TObjNum() { }
    void SetNum(int i) { num = i; }
    int GetNum() const { return num; }
    void Print(Option_t *) const
        { printf("num = %d\n", num); }
    Bool_t IsEqual(TObject *obj) const
        { return num == ((TObjNum*)obj)->num; }
    Bool_t IsSortable() const { return kTRUE; }
    Int_t Compare(TObject *obj) const
        { if (num < ((TObjNum*)obj)->num)
            return -1;
          else if (num > ((TObjNum*)obj)->num)
            return 1;
          else
            return 0; }
    ULong_t Hash() const { return num; }
};
```

The TIter Generic Iterator

As stated above, the **TIterator** class is abstract; it is not possible to create **TIterator** objects. However, it should be possible to write generic code to process all members of a collection so there is a need for a generic iterator object. A **TIter** object acts as generic iterator. It provides the same `Next()` and `Reset()` methods as **TIterator** although it has no idea how to support them! It works as follows:

- To create a **TIter** object its constructor must be passed an object that inherits from **TCollection**. The **TIter** constructor calls the `MakeIterator()` method of this collection to get the appropriate iterator object that inherits from **TIterator**.
- The `Next()` and `Reset()` methods of **TIter** simply call the `Next()` and `Reset()` methods of the iterator object.

So **TIter** simply acts as a wrapper for an object of a concrete class inheriting from **TIterator**.

To see this working in practice, consider the **TObjArray** collection. Its associated iterator is **TObjArrayIter**. Suppose `myarray` is a pointer to a **TObjArray**, i.e.

```
TObjArray *myarray;
```

which contains `MyClass` objects. To create a **TIter** object called `myiter`:

```
TIter myiter(myarray);
```

As shown in the diagram, this results in several methods being called:

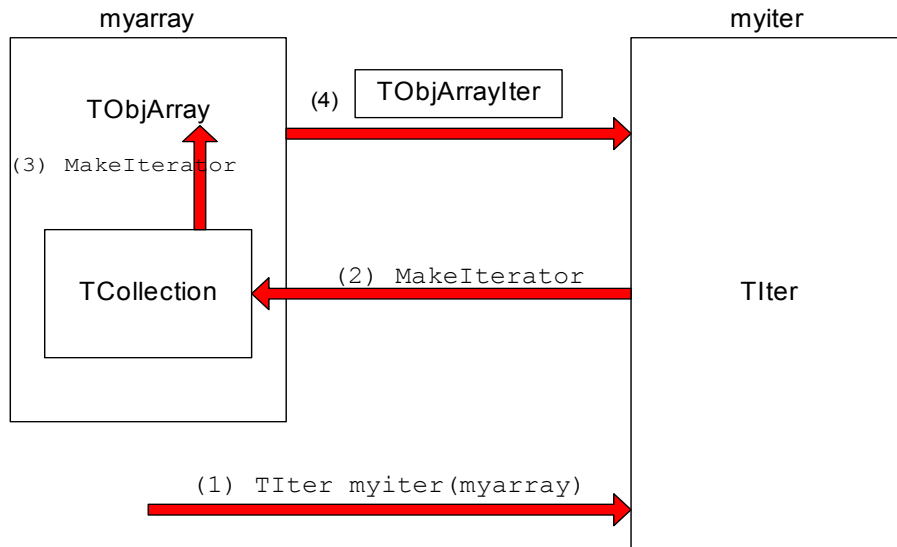

- (1) The **TIter** constructor is passed a **TObjArray**
- (2) **TIter** asks embedded **TCollection** to make an iterator
- (3) **TCollection** asks **TObjArray** to make an iterator
- (4) **TObjArray** returns a **TObjArrayIter**.

Now define a pointer for `MyClass` objects and set it to each member of the **TObjArray**:

```

MyClass *myobject;
while ((myobject = (MyClass *)myiter.Next())) {
    // process myobject
}

```

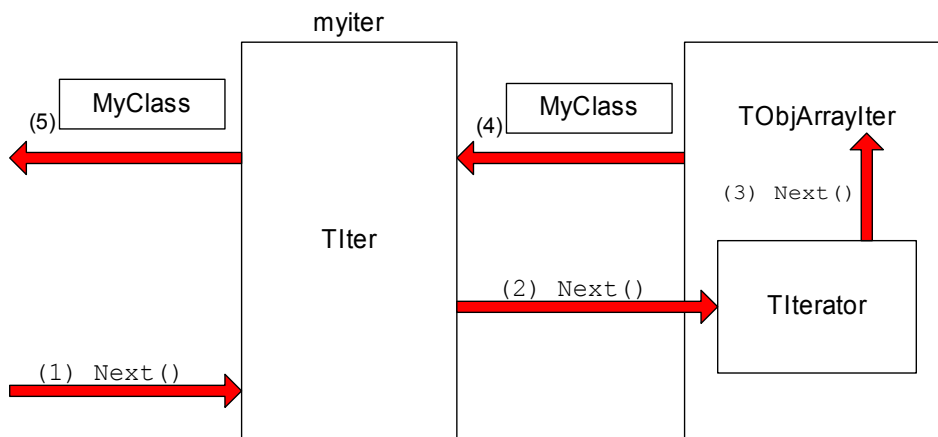

The heart of this is the `myiter.Next()` expression which does the following:

- (1) The `Next()` method of the **TIter** object `myiter` is called
- (2) The **TIter** forwards the call to the **TIterator** embedded in the **TObjArrayIter**
- (3) **TIterator** forwards the call to the **TObjArrayIter**
- (4) **TObjArrayIter** finds the next `MyClass` object and returns it
- (5) **TIter** passes the `MyClass` object back to the caller

Sometimes the **TIter** object is called `next`, and then instead of writing: `next.Next()` which is legal, but looks rather odd, iteration is written as `next()`. This works because the function operator `()` is defined for the **TIter** class to be equivalent to the `Next()` method.

The TList Collection

A **TList** is a doubly linked list. Before being inserted into the list the object pointer is wrapped in a **TObjLink** object that contains, besides the object pointer also a previous and next pointer.

Objects are typically added using:

- `Add()`
- `AddFirst()`, `AddLast()`
- `AddBefore()`, `AddAfter()`

Main features of TList: very low cost of adding/removing elements anywhere in the list.

Overhead per element: 1 **TObjLink**, i.e. two 4 (or 8) byte pointers + pointer to `vtable` = 12 (or 24) bytes.

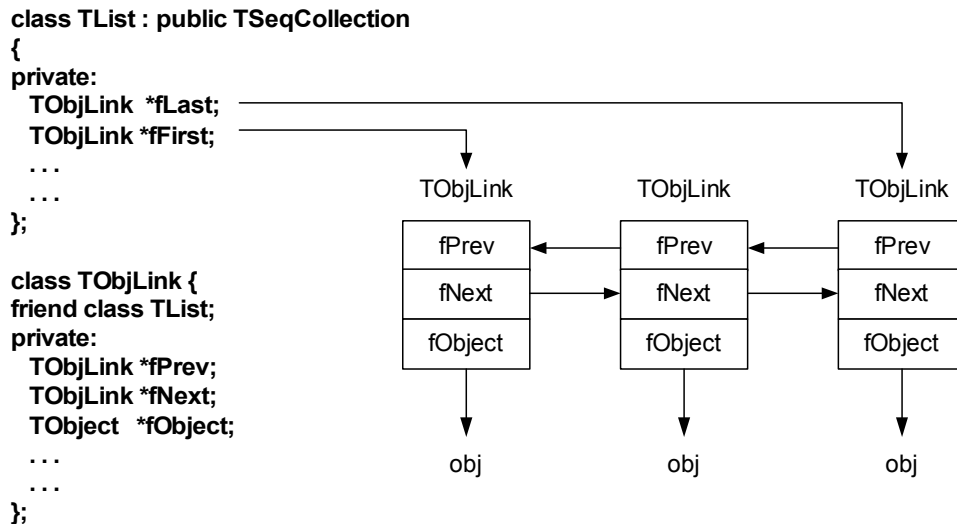

This diagram shows the internal data structure of a **TList**.

Iterating Over a TList

There are basically four ways to iterate over a **TList**:

(1) Using the **ForEach** script:

```
GetListOfPrimitives()->ForEach(TObj,Draw)();
```

(2) Using the **TList** iterator **TListIter** (via the wrapper class **TIter**):

```
TIter next(GetListOfTracks());
while ((TTrack *obj = (TTrack *)next())
    obj->Draw();
```

(3) Using the **TObjLink** list entries (that wrap the **TObject***):

```
TObjLink *lnk = GetListOfPrimitives()->FirstLink();
while (lnk) {
    lnk->GetObject()->Draw();
    lnk = lnk->Next();
}
```

(4) Using the **TList**'s **After()** and **Before()** member functions:

```
TFree *idcur = this;
while (idcur) {
    ...
    idcur = (TFree*)GetListOfFree()->After(idcur);
}
```

Method 1 uses internally method 2.

Method 2 works for all collection classes. **TIter** overloads **operator()**.

Methods 3 and 4 are specific for **TList**.

Methods 2, 3 and 4 can also easily iterate backwards using either a backward **TIter** (using argument **kIterBackward**) or by using **LastLink()** and **lnk->Prev()** or by using the **Before()** method.

The TObjArray Collection

A **TObjArray** is a collection which supports traditional array semantics via the overloading of **operator[]**. Objects can be directly accessed via an index. The array expands automatically when objects are added. At creation time one specifies the default array size (default = 16) and lower bound (default = 0). Resizing involves a re-allocation and a copy of the old array to the new. This can be costly if done too often. If possible, set initial size close to expected final size. Index validity is always checked (if you are 100% sure and maximum performance is needed you can use **UncheckedAt()** instead of **At()** or **operator[]**). If the stored objects are sort able the array can be sorted using **Sort()**. Once sorted, efficient searching is possible via the **BinarySearch()** method.

This diagram shows the internal data structure of a **TObjArray**:

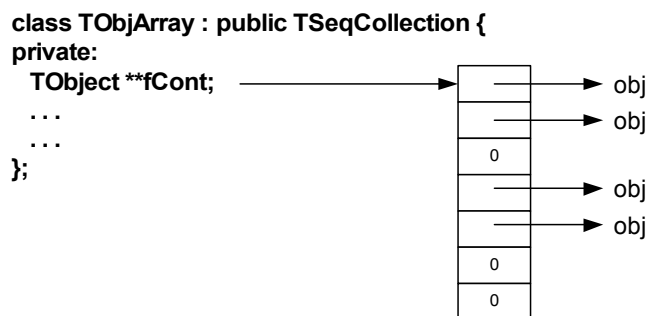

Iterating can be done using a **TIter** iterator or via a simple for loop:

```
for (int i = 0; i <= fArr.GetLast(); i++)
    if ((track = (TTrack*)fArr[i]) // or fArr.At(i)
        track->Draw();
```

Main features of **TObjArray**: simple, well known array semantics. **Overhead per element**: none, except possible over sizing of **fCont**.

TClonesArray – An Array of Identical Objects

A **TClonesArray** is an array of identical (clone) objects. The memory for the objects stored in the array is allocated only once in the lifetime of the clones array. All objects must be of the same class and the object must have a fixed size (i.e. they may not allocate other objects). For the rest this class has the same properties as a **TObjArray**.

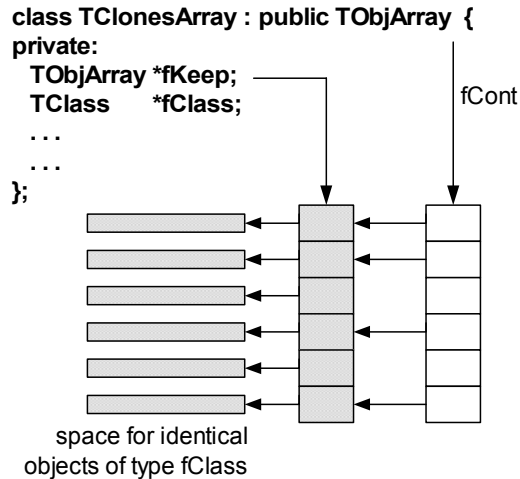

The class is specially designed for repetitive data analysis tasks, where in a loop many times the same objects, are created and deleted. The diagram above shows the internal data structure of a **TClonesArray**:

The Idea Behind TClonesArray

To reduce the very large number of new and delete calls in large loops like this ($O(100000) \times O(10000)$ times new/delete):

```
TObjArray a(10000);
while (TEvent *ev = (TEvent *)next()) {           // O(100000)
    for (int i = 0; i < ev->Ntracks; i++) {        // O(10000)
        a[i] = new TTrack(x,y,z,...);
        ...
    }
    ...
    a.Delete();
}
```

You better use a **TClonesArray** which reduces the number of new/delete calls to only $O(10000)$:

```
TClonesArray a("TTrack", 10000);
while (TEvent *ev = (TEvent *)next()) {           // O(100000)
    for (int i = 0; i < ev->Ntracks; i++) {        // O(10000)
        new(a[i]) TTrack(x,y,z,...);
        ...
    }
    ...
    a.Delete();
}
```

Considering that a pair of new/delete calls on average cost about $70 \mu\text{s}$, $O(10^9)$ new/deletes will save about 19 hours.

For the other collections see the class reference guide on the web and the test program `$ROOTSYS/test/tcollex.cxx`.

Template Containers and STL

Some people dislike polymorphic containers because they are not truly “type safe”. In the end, the compiler leaves it the user to ensure that the types are correct. This only leaves the other alternative: creating a new class each time a new (container organization) / (contained object) combination is needed. To say the least this could be very tedious. Most people faced with this choice would, for each type of container:

1. Define the class leaving a dummy name for the contained object type.
2. When a particular container was needed, copy the code and then do a global search and replace for the contained class.

C++ has a built in template scheme that effectively does just this. For example:

```
template<class T>
class ArrayContainer {
private:
    T *member[10];
    ...
};
```

This is an array container with a 10-element array of pointers to T , it could hold up to 10 T objects. This array is flawed because it is static and hard-coded, it should be dynamic. However, the important point is that the template statement indicates that T is a template, or parameterized class. If we need an `ArrayContainer` for `Track` objects, it can be created by:

```
ArrayContainer<Track> MyTrackArrayContainer;
```

C++ takes the parameter list, and substitutes `Track` for T throughout the definition of the class `ArrayContainer`, then compiles the code so generated, effectively doing the same we could do by hand, but with a lot less effort.

This produces code that is type safe, but does have different drawbacks:

- Templates make code harder to read.
- At the time of writing this documentation, some compilers can be very slow when dealing with templates.
- It does not solve the problem when a container has to hold a heterogeneous set of objects.
- The system can end up generating a great deal of code; each container/object combination has its own code, a phenomenon that is sometimes referred to as *code bloat*.

The Standard Template Library (STL) is part on ANSI C++, and includes a set of template containers.

15 Physics Vectors

The physics vector classes describe vectors in three and four dimensions and their rotation algorithms. The classes were ported to root from CLHEP see:

<http://wwwinfo.cern.ch/asd/lhc++/clhep/manual/UserGuide/Vector/vector.html>

The Physics Vector Classes

In order to use the physics vector classes you will have to load the Physics library:

```
gSystem.Load("libPhysics.so");
```

There are four classes in this package. They are:

TVector3 is a general three-vector. A **TVector3** may be expressed in Cartesian, polar, or cylindrical coordinates. Methods include dot and cross products, unit vectors and magnitudes, angles between vectors, and rotations and boosts. There are also functions of particular use to HEP, like pseudo-rapidity, projections, and transverse part of a **TVector3**, and kinetic methods on 4-vectors such as Invariant Mass of pairs or containers of particles.

TLorentzVector is a general four-vector class, which can be used either for the description of position and time (x, y, z, t) or momentum and energy (p_x, p_y, p_z, E).

TRotation is a class describing a rotation of a **TVector3** object.

TLorentzRotation is a class to describe the Lorentz transformations including Lorentz boosts and rotations.

There is also a **TVector2** that is a basic implementation of a vector in two dimensions and not part of the CLHEP translation.

TVector3

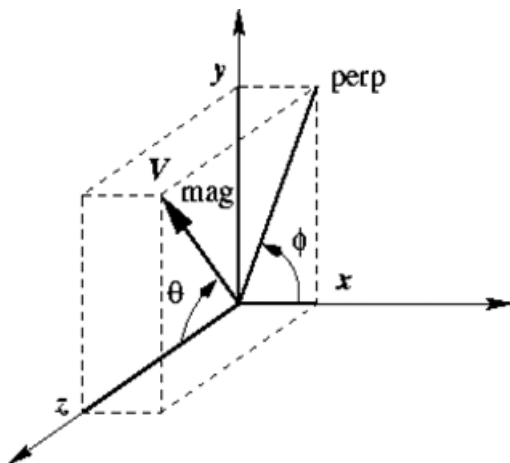

TVector3 is a general three vector class, which can be used for description of different vectors in 3D. Components of three vectors:

x, y, z - basic components

θ = azimuth angle

ϕ = polar angle

magnitude = $\text{mag} = \sqrt{x^2 + y^2 + z^2}$

transverse component = $\text{perp} = \sqrt{x^2 + y^2}$

Using the **TVector3** class you should remember that it contains only common features of three vectors and lacks methods specific for some particular vector values. For example, it has no translated function because translation has no meaning for vectors.

Declaration / Access to the components

TVector3 has been implemented as a vector of three `Double_t` variables, representing the Cartesian coordinates. By default the values are initialized to zero, however you can change them in the constructor:

```
TVector3 v1;           // v1 = (0,0,0)
TVector3 v2(1);       // v2 = (1,0,0)
TVector3 v3(1,2,3);   // v3 = (1,2,3)
TVector3 v4(v2);      // v4 = v2
```

It is also possible (but not recommended) to initialize a **TVector3** with a `Double_t` or `Float_t` C array.

You can get the components by name or by index:

```
xx = v1.X();    or   xx = v1(0);
yy = v1.Y();    yy = v1(1);
zz = v1.Z();    zz = v1(2);
```

The methods `SetX()`, `SetY()`, `SetZ()` and `SetXYZ()` allow you to set the components:

```
v1.SetX(1.); v1.SetY(2.); v1.SetZ(3.);
v1.SetXYZ(1.,2.,3.);
```

Other Coordinates

To get information on the **TVector3** in spherical (rho, phi, theta) or cylindrical (z, r, theta) coordinates, the following methods can be used.

```
Double_t m = v.Mag();
// get magnitude (=rho=Sqrt(x*x+y*y+z*z))
Double_t m2 = v.Mag2(); // get magnitude squared
Double_t t = v.Theta(); // get polar angle
Double_t ct = v.CosTheta(); // get cos of theta
Double_t p = v.Phi(); // get azimuth angle
Double_t pp = v.Perp(); // get transverse component
Double_t pp2 = v.Perp2(); // get transverse squared
```

It is also possible to get the transverse component with respect to another vector:

```
Double_t ppv1 = v.Perp(v1);
Double_t pp2v1 = v.Perp2(v1);
```

The pseudo-rapidity ($\eta = -\ln(\tan(\phi/2))$) can be get by `Eta()` or `PseudoRapidity()`:

```
Double_t eta = v.PseudoRapidity();
```

These setters change one of the non-Cartesian coordinates:

```
v.SetTheta(.5); // keeping rho and phi
v.SetPhi(.8); // keeping rho and theta
v.SetMag(10.); // keeping theta and phi
v.SetPerp(3.); // keeping z and phi
```

Arithmetic / Comparison

The `TVector3` class has operators to add, subtract, scale and compare vectors:

```
v3 = -v1;
v1 = v2+v3;
v1 += v3;
v1 = v1 - v3;
v1 -= v3;
v1 *= 10;
v1 = 5*v2;
if(v1 == v2) {...}
if(v1 != v2) {...}
```

Related Vectors

```
v2 = v1.Unit();           // get unit vector parallel to v1
v2 = v1.Orthogonal();    // get vector orthogonal to v1
```

Scalar and Vector Products

```
s = v1.Dot(v2);           // scalar product
s = v1 * v2;              // scalar product
v = v1.Cross(v2);        // vector product
```

Angle between Two Vectors

```
Double_t a = v1.Angle(v2);
```

Rotation around Axes

```
v.RotateX(.5);
v.RotateY(TMath::Pi());
v.RotateZ(angle);
```

Rotation around a Vector

```
v1.Rotate(TMath::Pi()/4, v2); // rotation around v2
```

Rotation by TRotation

`TVector3` objects can be rotated by `TRotation` objects using the `Transform()` method, the operator `*=`, or the operator `*` of the `TRotation` class. See the later section on `TRotation`.

```
TRotation m;
...
v1.Transform(m);
v1 = m*v1;
v1 *= m;           // v1 = m*v1
```

Transformation from Rotated Frame

This code transforms v_1 from the rotated frame (z' parallel to direction, x' in the theta plane and y' in the xy plane as well as perpendicular to the theta plane) to the (x, y, z) frame.

```
TVector3 direction = v.Unit()
v1.RotateUz(direction); // direction must be TVector3 of unit length
```

TRotation

The **TRotation** class describes a rotation of **TVector3** object. It is a 3×3 matrix of `Double_t`:

$$\begin{vmatrix} xx & xy & xz \\ yx & yy & yz \\ zx & zy & zz \end{vmatrix}$$

It describes a so-called active rotation, i.e. a rotation of objects inside a static system of coordinates. In case you want to rotate the frame and want to know the coordinates of objects in the rotated system, you should apply the inverse rotation to the objects. If you want to transform coordinates from the rotated frame to the original frame you have to apply the direct transformation. A rotation around a specified axis means counterclockwise rotation around the positive direction of the axis.

Declaration, Access, Comparisons

```
TRotation r; // r initialized as identity
TRotation m(r); // m = r
```

There is no direct way to set the matrix elements - to ensure that a **TRotation** always describes a real rotation. But you can get the values by with the methods `XX()` .. `ZZ()` or the `(,)` operator:

```
Double_t xx = r.XX(); // the same as xx=r(0,0)
          xx = r(0,0);
if (r==m) {...} // test for equality
if (r!=m) {...} // test for inequality
if (r.IsIdentity()) {...} // test for identity
```

Rotation around Axes

The following matrices describe counter-clockwise rotations around the coordinate axes and are implemented in: `RotateX()`, `RotateY()` and `RotateZ()`:

$$R_x(a) = \begin{vmatrix} 1 & 0 & 0 \\ 0 & \cos(a) & -\sin(a) \\ 0 & \sin(a) & \cos(a) \end{vmatrix}$$

$$R_y(a) = \begin{vmatrix} \cos(a) & 0 & \sin(a) \\ 0 & 1 & 0 \\ -\sin(a) & 0 & \cos(a) \end{vmatrix}$$

$$R_z(a) = \begin{vmatrix} \cos(a) & -\sin(a) & 0 \\ \sin(a) & \cos(a) & 0 \\ 0 & 0 & 1 \end{vmatrix}$$

```
r.RotateX(TMATH::Pi()); // rotation around the x-axis
```

Rotation around Arbitrary Axis

The `Rotate()` method allows you to rotate around an arbitrary vector (not necessary a unit one) and returns the result.

```
r.Rotate(TMATH::Pi()/3,TVector3(3,4,5));
```

It is possible to find a unit vector and an angle, which describe the same rotation as the current one:

```
Double_t angle;  
TVector3 axis;  
r.GetAngleAxis(angle,axis);
```

Rotation of Local Axes

The `RotateAxes()` method adds a rotation of local axes to the current rotation and returns the result:

```
TVector3 newX(0,1,0);  
TVector3 newY(0,0,1);  
TVector3 newZ(1,0,0);  
a.RotateAxes(newX,newY,newZ);
```

Methods `ThetaX()`, `ThetaY()`, `ThetaZ()`, `PhiX()`, `PhiY()`, `PhiZ()` return azimuth and polar angles of the rotated axes:

```
Double_t tx,ty,tz,px,py,pz;  
tx= a.ThetaX();  
...  
pz= a.PhiZ();
```

Inverse Rotation

```
TRotation a,b;  
...  
b = a.Inverse(); // b is inverse of a, a is unchanged  
b = a.Invert(); // invert a and set b = a
```

Compound Rotations

The operator `*` has been implemented in a way that follows the mathematical notation of a product of the two matrices which describe the two consecutive rotations. Therefore the second rotation should be placed first:

```
r = r2 * r1;
```

Rotation of TVector3

The `TRotation` class provides an operator `*` which allows expressing a rotation of a `TVector3` analog to the mathematical notation:

$$\begin{pmatrix} x' \\ y' \\ z' \end{pmatrix} = \begin{pmatrix} xx & xy & xz \\ yx & yy & yz \\ zx & zy & zz \end{pmatrix} \begin{pmatrix} x \\ y \\ z \end{pmatrix}$$

```
TRotation r;
TVector3 v(1,1,1);
v = r * v;
```

You can also use the `Transform()` method or the operator `*=` of the `TVector3` class:

```
TVector3 v;
TRotation r;
v.Transform(r);
```

TLorentzVector

TLorentzVector is a general four-vector class, which can be used either for the description of position and time (x, y, z, t) or momentum and energy (p_x, p_y, p_z, E).

Declaration

TLorentzVector has been implemented as a set a `TVector3` and a `Double_t` variable. By default all components are initialized by zero.

```
TLorentzVector v1;           // initialized by (0.,0.,0.,0.)
TLorentzVector v2(1.,1.,1.,1.);
TLorentzVector v3(v1);
TLorentzVector v4(TVector3(1.,2.,3.),4.);
```

For backward compatibility there are two constructors from a `Double_t` and `Float_t` array.

Access to Components

There are two sets of access functions to the components of a **TLorentzVector**: `X()`, `Y()`, `Z()`, `T()` and `Px()`, `Py()`, `Pz()` and `E()`. Both sets return the same values but the first set is more relevant for use where **TLorentzVector** describes a combination of position and time and the second set is more relevant where **TLorentzVector** describes momentum and energy:

```
Double_t xx = v.X();
...
Double_t tt = v.T();
Double_t px = v.Px();
...
Double_t ee = v.E();
```

The components of **TLorentzVector** can also accessed by index:

```
xx = v(0);           or           xx = v[0];
yy = v(1);           yy = v[1];
zz = v(2);           zz = v[2];
tt = v(3);           tt = v[3];
```

You can use the `Vect()` method to get the vector component of **TLorentzVector**:

```
TVector3 p = v.Vect();
```

For setting components there are two methods: `SetX()`, ..., `SetPx()`, ...:

```
v.SetX(1.);           or           v.SetPx(1.);
...
v.SetT(1.);           v.SetE(1.);
```

To set more the one component by one call you can use the `SetVect()` function for the **TVector3** part or `SetXYZT()`, `SetPxPyPzE()`. For convenience there is also a `SetXYZM()`:

```
v.SetVect(TVector3(1,2,3));
v.SetXYZT(x,y,z,t);
v.SetPxPyPzE(px,py,pz,e);
v.SetXYZM(x,y,z,m); // v = (x,y,z,e = Sqrt(x*x+y*y+z*z+m*m))
```

Vector Components in Non-Cartesian Coordinates

There are a couple of methods to get and set the **TVector3** part of the parameters in spherical coordinate systems:

```
Double_t m, theta, cost, phi, pp, pp2, ppv2, pp2v2;
m = v.Rho();
t = v.Theta();
cost = v.CosTheta();
phi = v.Phi();
v.SetRho(10.);
v.SetTheta(TMath::Pi()*0.3);
v.SetPhi(TMath::Pi());
```

or get information about the r-coordinate in cylindrical systems:

```
Double_t pp, pp2, ppv2, pp2v2;
pp = v.Perp(); // get transverse component
pp2 = v.Perp2(); // get transverse component squared
ppv2 = v.Perp(v1); // get transverse component with
// respect to another vector
pp2v2 = v.Perp(v1);
```

for convenience there are two more set functions `SetPtEtaPhiE(pt,eta,phi,e)` and `SetPtEtaPhiM(pt,eta,phi,m)`

Arithmetic and Comparison Operators

The **TLorentzVector** class provides operators to add subtract or compare four-vectors:

```
v3 = -v1;
v1 = v2+v3;
v1+= v3;
v1 = v2 + v3;
v1-= v3;
if(v1 == v2) {...}
if(v1 != v3) {...}
```

Magnitude/Invariant mass, beta, gamma, scalar product

The scalar product of two four-vectors is calculated with the $(-, -, -, +)$ metric:

$$\mathbf{s} = \mathbf{v1} \cdot \mathbf{v2} = t1 \cdot t2 - x1 \cdot x2 - y1 \cdot y2 - z1 \cdot z2$$

The magnitude squared `mag2` of a four-vector is therefore:

$$\mathbf{mag2} = \mathbf{v} \cdot \mathbf{v} = t \cdot t - x \cdot x - y \cdot y - z \cdot z$$

If `mag2` is negative

$$\mathbf{mag} = -\text{Sqrt}(-\mathbf{mag} \cdot \mathbf{mag})$$

The methods are:

```
Double_t s, s2;
s = v1.Dot(v2);           // scalar product
s = v1*v2;                // scalar product
s2 = v.Mag2();           or   s2 = v.M2();
s = v.Mag();              s = v.M();
```

Since in case of momentum and energy the magnitude has the meaning of invariant mass **TLorentzVector** provides the more meaningful aliases `M2()` and `M()`. The methods `Beta()` and `Gamma()` returns beta and $\gamma = 1/\sqrt{1-\beta^2}$

Lorentz Boost

A boost in a general direction can be parameterized with three parameters which can be taken as the components of a three vector $\mathbf{b} = (b_x, b_y, b_z)$. With $\mathbf{x} = (x, y, z)$ and $\gamma = 1/\sqrt{1-\beta^2}$, an arbitrary active Lorentz boost transformation (from the rod frame to the original frame) can be written as:

$$x = x' + (\gamma - 1) / (\beta^2) * (\mathbf{b} \cdot \mathbf{x}') * \mathbf{b} + \gamma * \mathbf{t}' \cdot \mathbf{b}$$
$$t = \gamma (t' + \mathbf{b} \cdot \mathbf{x}')$$

The `Boost()` method performs a boost transformation from the rod frame to the original frame. `BoostVector()` returns a **TVector3** of the spatial components divided by the time component:

```
TVector3 b;
v.Boost(bx, by, bz);
v.Boost(b);
b = v.BoostVector(); // b=(x/t, y/t, z/t)
```

Rotations

There are four sets of functions to rotate the **TVector3** component of a **TLorentzVector**:

Rotation around Axes

```
v.RotateX(TMath::Pi()/2.);
v.RotateY(.5);
v.RotateZ(.99);
```

Rotation around an Arbitrary Axis

```
v.Rotate(TMath::Pi()/4., v1); // rotation around v1
```

Transformation from Rotated Frame

```
v.RotateUz(direction); // direction must be a unit TVector3
```

Rotation by TRotation

```
TRotation r;
v.Transform(r); //or v *= r; (v = r*v)
```

Miscellaneous

Angle between Two Vectors

```
Double_t a = v1.Angle(v2); // get angle between v1 and v2
```

Light-cone Components

Methods `Plus()` and `Minus()` return the positive and negative light-cone components:

```
Double_t pcone = v.Plus();
Double_t mcone = v.Minus();
```

Transformation by `TLorentzRotation`

A general Lorentz transformation (see class `TLorentzRotation`) can be used by the `Transform()` method, the `*=`, or `*` operator of the `TLorentzRotation` class:

```
TLorentzRotation l;
v.Transform(l);
v = l*v;    or    v *= l;    // v = l*v
```

TLorentzRotation

The `TLorentzRotation` class describes Lorentz transformations including Lorentz boosts and rotations (see `TRotation`)

$$\text{lambda} = \begin{vmatrix} \text{xx} & \text{xy} & \text{xz} & \text{xt} \\ \text{yx} & \text{yy} & \text{yz} & \text{yt} \\ \text{zx} & \text{zy} & \text{zz} & \text{zt} \\ \text{tx} & \text{ty} & \text{tz} & \text{tt} \end{vmatrix}$$

Declaration

By default it is initialized to the identity matrix, but it may also be initialized by other `TLorentzRotation`, by a pure `TRotation` or by a boost:

```
TLorentzRotation l; // l is initialized as identity
TLorentzRotation m(l); // m = l
TRotation r;
TLorentzRotation lr(r);
TLorentzRotation lb1(bx,by,bz);
TVector3 b;
TLorentzRotation lb2(b);
```

The Matrix for a Lorentz boosts is:

$$\begin{vmatrix} 1+\text{gamma}'*\text{bx}* \text{bx} & \text{gamma}'*\text{bx}* \text{by} & \text{gamma}'*\text{bx}* \text{bz} & \text{gamma}* \text{bx} \\ \text{gamma}'*\text{bx}* \text{bz} & 1+\text{gamma}'*\text{by}* \text{by} & \text{gamma}'*\text{by}* \text{bz} & \text{gamma}* \text{by} \\ \text{gamma}'*\text{bz}* \text{bx} & \text{gamma}'*\text{bz}* \text{by} & 1+\text{gamma}'*\text{bz}* \text{bz} & \text{gamma}* \text{bz} \\ \text{gamma}* \text{bx} & \text{gamma}* \text{by} & \text{gamma}* \text{bz} & \text{gamma} \end{vmatrix}$$

with the boost vector $b=(b_x, b_y, b_z)$; $\text{gamma}=1/\text{sqrt}(1-\text{beta}*\text{beta})$;
 $\text{gamma}'=(\text{gamma}-1)/\text{beta}*\text{beta}$

Access to the Matrix Components/Comparisons

The access to the matrix components is possible with the methods `XX()`, `XY()` ... `TT()`, and with the operator `(int,int)`:

```
Double_t xx;
TLorentzRotation l;
xx = l.XX(); // gets the xx component
xx = l(0,0); // gets the xx component
if (l == m) {...} // test for equality
if (l != m) {...} // test for inequality
if (l.IsIdentity()) {...} // test for identity
```

Transformations of a Lorentz Rotation

Compound transformations

There are four possibilities to find the product of two `TLorentzRotation` transformations:

```
TLorentzRotation a,b,c;
c = b*a; // product
c = a.MatrixMultiplication(b); // a is unchanged
a *= b; // a=a*b
c = a.Transform(b) // a=b*a then c=a
```

Lorentz boosts

```
Double_t bx, by, bz;
TVector3 v(bx,by,bz);
TLorentzRotation l;
l.Boost(v);
l.Boost(bx,by,bz);
```

Rotations

```
TVector3 axis;
l.RotateX(TMath::Pi()); // rotation around x-axis
l.Rotate(.5,axis); // rotation around specified vector
```

Inverse transformation

The matrix for the inverse transformation of a `TLorentzRotation` is as follows:

$$\begin{vmatrix} xx & yx & zx & -tx \\ xy & yy & zy & -ty \\ xz & yz & zz & -tz \\ -xt & -yt & -zt & tt \end{vmatrix}$$

Use the method `Inverse()` to return the inverse transformation keeping the current one unchanged. The method `Invert()` inverts the current `TLorentzRotation`:

```
l1 = l2.Inverse(); // l1 is inverse of l2, l2 unchanged
l1 = l2.Invert(); // invert l2, then l1=l2
```

Transformation of a TLorentzVector

To apply `TLorentzRotation` to `TLorentzVector` you can use either the `VectorMultiplication()` method or the `*` operator. You can also use the `Transform()` function and the `*=` operator of the `TLorentzVector` class.

```
TLorentzVector v;
TLorentzRotation l;
...
v=l.VectorMultiplication(v);
v = l * v;
v.Transform(l);
v *= l;           // v = l*v
```

Physics Vector Example

To see an example of using physics vectors you can look at the test file. It is in `$ROOTSYS/test/TestVectors.cxx`. The vector classes are not loaded by default, and to run it, you will need to load `libPhysics.so` first:

```
root[] .L $ROOTSYS/lib/libPhysics.so
root[] .x TestVectors.cxx
```

To load the physics vector library in a ROOT application use:

```
gSystem->Load("libPhysics");
```

The example `$ROOTSYS/test/TestVectors.cxx` does not return much, especially if all went well, but when you look at the code you will find examples for many calls.

16 Matrix Elements and Operations

The operator:

```
operator*(const TMatrix &source1, const TMatrix &source2);
```

multiplies matrix of transposed shapes: $a(m, n) * b(n, m)$.

It does not calculate /correct the matrix determinant if the user does not request its value. The reason for this is that after rescaling by the diagonal it might be too large or too small.

If `rank(matrix) <= 3` determinant and matrix inversion formulas are hard-coded in order to improve speed, as requested by Nicolas Produit

<http://root.cern.ch/root/roottalk/roottalk02/1136.html>

The implemented class **TMatrixFlat** lets you access the matrix elements as a flat array. Functionalities are identical to **TMatrixRow**, **TMatrixColumn** and **TMatrixDiag**.

The following constructors of **TVector** are added:

```
TVector(const TMatrixRow &mr);  
TVector(const TMatrixColumn &mc);  
TVector(const TMatrixDiag &md);
```

Operations like

```
TMatrix(a, 2) *= TMatrix(b, 3)
```

are now supported elements in **TVector**, **TMatrix**, **TMatrixRow**. They can be accessed with operator `()` and `[]`.

17 The ROOT Geometry Package

The new ROOT geometry package is a tool designed for building, browsing, tracking and visualizing detector geometry. The code works standalone with respect to any tracking Monte-Carlo engine; therefore it does not contain any constraints related to physics. However, the package defines a number of hooks in order to ease-up tracking, allowing user-defined objects to be attached to the basic architectural structures or superimposed on top of them. The modeling functionality was designed to optimize particle transport through complex geometries and it is accessible in an easy and transparent way. The package is currently under development and new features will be implemented, but the basic functionality has already been extensively tested on several detector geometries. The final goal is to be able to use the same geometry for several purposes, such as tracking, reconstruction or visualization, taking advantage of the ROOT features related to bookkeeping, I/O, histogramming, browsing and graphical interfaces.

Architecture

The geometrical modeler is the most important component of the package and it provides answers to the basic questions like "Where am I ?" or "How far from the next boundary ?", but also to more complex ones like "How far from the closest surface ?" or "On which angle is crossed next boundary ?".

The architecture of the modeler is a combination between a GEANT-like containment scheme and a normal constructive solid geometry (CSG) binary tree at the level of shapes. An important common feature of all detector geometry descriptions is the mother-daughter concept. This is the most natural approach when tracking is concerned and imposes a set of constraints to the way geometry is defined. CSG composition is used only in order to create more complex shapes from an existing set of primitives through Boolean operations.

Volumes and Nodes

Practically any geometry defined in GEANT style can be mapped by the modeler. The basic components used for building the logical hierarchy of the geometry are called "volumes" and "nodes". Volumes (sometimes called "solids") are fully defined geometrical objects having a given shape and material and possibly containing a list of nodes. Nodes represent just positioned instances of volumes inside a container volume and they are not directly defined by user. They are automatically created as a result of adding one volume inside other or as the result of dividing a volume according some pattern. A given volume can be positioned several times in the geometry. The dividing operation is creating automatically the list of division nodes inside. The elementary volumes created during this process follow the same scheme as usual volumes, therefore it is possible to position further geometrical structures inside or to divide them further more.

Nodes are aware of their geometrical transformation which is always defined with respect to their mother (relative positioning). Reflection matrices are allowed. In order to avoid ambiguities in the point classification process, this architecture does not allow positioned objects within the same container to overlap each other or to extrude their mother. An exception to this rule is however allowed in order to produce Boolean operations among solids without using Boolean composition. In this case the fact that a positioned volume might overlap with other must be specified by the user. However, this feature can lead to unpredictable results if not used with care and reduces the modeler tracking performance.

The structure defined in this way is a graph structure since volumes are replicable (same volume can become daughter node of several other volumes), every volume becoming a branch in this graph. Any volume in the logical graph can become the actual top volume at run time, the modeler behaving in this case as if the geometry is represented by the graph below this volume.

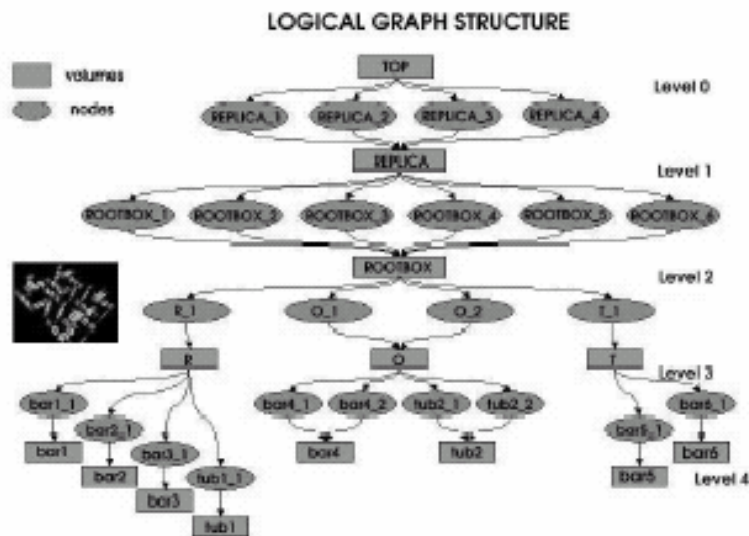

All volumes have to be fully aware of their containers when the geometry is closed. They will build additional structures in order to fasten-up the search algorithms. In order to be able to compute point and vector transformations between the master reference frame and the local frame of a node, the global transformation of this node must be computed by multiplying all transformations on the node path. This transformation can be only stored in a physical tree that represents the expansion of the logical graph. The size of this tree is proportional to the number of links in the graph and can lead to huge data structures for complex geometries. In order to solve this problem, the modeler implements a caching mechanism that expands with higher priority only the most frequently used parts of the geometry. The global transformations are stored compressed in memory whenever it contains just simple translations/rotations.

Shapes and Materials

The primitive shapes supported by the package are basically the GEANT3 shapes (boxes, tubes, trapezoids, cones, spheres, polycones, and polygons) plus arbitrary wedges with eight vertices on two parallel planes. All basic primitives inherit from the box class since the bounding box of a solid is used for optimizing the tracking algorithms. They also implement the virtual methods defined in the virtual class **TGeoShape** (point and segment classification). User-defined primitives can be directly plugged into the modeler provided that they override these methods.

Composite shapes can be created in a transparent way via Boolean expressions using union (+), subtraction (-) and intersection (*) operations. These operations apply to existing shapes identified by name which become components of the Boolean expression. Transformation matrices can apply to each component and they can be appended to shape names by using a colon (:).

Each matrix describes the relative transformation of a component with respect to the binary combination to which it is applied. A valid Boolean expression can be:

```
(tube + tube:mat1) - box:mat2
```

A missing transformation identifier is automatically substituted by an identity transformation.

Any shape must be associated with a material or mixture in order to create a volume. Materials are defined by single elements with given atomic mass and charge, while mixtures are deriving from the material class and represent combinations of elements. The density, radiation and absorption lengths have to be specified. A list of default materials is filled by the manager class at build time. User-defined materials are just added to this list and can be retrieved by name.

An Interactive Session

Provided that geometry was successfully built and closed, the **TGeoManager** class will register itself to ROOT and the logical/physical structures will become immediately browsable. Starting from the geometry folder, the ROOT browser will display: the list of transformations and materials, the top volume and the top logical node. These last two can be fully expanded using the ROOT browser. All user utilities of classes **TGeoManager**, **TGeoVolume** and **TGeoNode** can be called via the context menu.

Drawing the Geometry

Any logical volume can be drawn via its `Draw()` member function. Several drawing options are currently supported and they can be directly accessed from the graphics user interface. Visualization offers full interactivity, supporting on-line rotations and picking of objects.

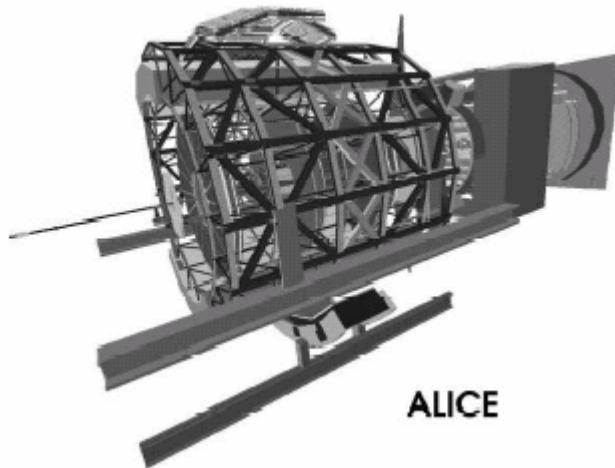

Particle Tracking

Tracking is the modeler feature allowing the transport of a given particle knowing its kinematics. A state is determined by any combination of the position $\sim r$ and direction $\sim n$ with respect to the world reference frame. The direction $\sim n$ must be a unit vector having as components the director cosines. The full classification of a given state will provide the following information: the deepest physical node containing the position vector, the distance to the closest boundary along the direction vector, the next physical node after propagating the current point with this distance and the safety distance to the nearest boundary. This information allows the propagation of particles inside a detector geometry by taking into account both geometrical and physical constraints.

The two most important features of the geometrical modeler concerning tracking are scalability and performance as function of the total number of physical nodes. The first refers to the possibility to make use of the available memory resources and at the same

time be able to resolve any geometrical query, while the second defines the capability of the modeler to respond quickly even for huge geometries. These parameters can become critical when simulating big experiments like those at LHC.

Table 1 presents the performance for finding a point for several tested geometries in comparison with GEANT3. A sample of one million points produced by a GEANT3 based tracking in a full simulation environment were collected. These points were supplied to both GEANT3 and ROOT modelers and the timings for point classification were compared. In order to determine if the answer of the two modelers was compatible, the full path for each point was also compared.

Checking the Geometry

Several checking methods are accessible from the volume context menu or the class interface. They generally apply only to the visible parts of the drawn geometry in order to ease geometry checking, and their implementation is in the **TGeoChecker** class.

In order to check a given point, the method `CheckPoint(x, y, z)` of **TGeoManager** draws the daughters of the volume containing the point one level down, printing the path to the deepest physical node holding this point. It also computes the closest distance to any boundary.

A method to check the validity of a given geometry is shooting random points. This can be called with `TGeoVolume::RandomPoints()` and it draws a volume with the current visualization settings. Random points are generated in the bounding box of the top drawn volume. The points are classified and drawn with the color of their deepest container. Only points inside visible nodes are drawn.

A ray tracing method can be called `TGeoVolume::RandomRays()`. This shoots rays from a given point in the local reference frame with random directions. The intersections with displayed nodes appear as segments having the color of the touched node.

Saving Geometry in a File

A new geometry package having geometrical modeling capabilities has been introduced in the ROOT framework. It provides a compatible architecture with GEANT descriptions and therefore allows mapping of existing detector geometries. It provides a simple user interface for its building, tracking and visualization features and it is fully decoupled from physics. It has a transparent and robust object-oriented design that was optimized in terms of performance and resource management for the most complex experimental geometry setups at LHC. These features are provided in order to be able to use an unique geometry description for all applications requiring it within the software framework of an experiment, such as simulation, reconstruction or event viewing.

Once geometry is successfully built, it can be saved in a root file calling:

```
TGeoManager::Export(const char *filename,
                   const char*keyname="", Option_t *option="v")
```

where:

`filename` is the name of the file to be written (mandatory)

`keyname` is the name of the key in the file (default "")

`option = "v"` is an export voxelization (default), otherwise voxelization is recomputed after loading the geometry

Loading geometry from file can be done via the static member function:

```
TGeoManager::Import(const char*filename, const char*keyname="",
                   Option_t *option="")
```

Example:

```
... geometry definition
root[0] gGeoManager->CloseGeometry();          // geometry ready
...
root[1] gGeoManager->Export("MyGeom.root"); //file produced root[0]
TGeoManager::Import("MyGeom.root"); // geometry ready
```

Boolean composite shapes (class **TGeoCompositeShape**) can be produced out of any shape known by the modeler, by using Boolean operators: union (+), intersection (*) and subtraction (-) associated with shape names. Composite shapes are deriving from the abstract **TGeoShape** class so they can be used also to define other composite shapes. Local transformation matrices can apply to composite shape components. A full component identifier looks like: `shape_name:matrix_name`. A composite shape is built using a Boolean expression of component identifiers:

```
cs = new TGeoCompositeShape("cs_name", "(A:m1+B:m2)-C");
```

where: A,B,C are names of shapes previously defined, while m1, m2 are names of transformations that should apply to shapes in the composition. Any valid Boolean expression is accepted. Missing transformation identifiers are interpreted as identity matrix. Transformations cannot be applied globally to such a Boolean expression (e.g. "(A+B):m1" is not valid, while "(A+B):m1-C" is).

Composite shapes cannot be visualized in the current version, but they are "visible" by the tracking methods `FindNode()` and `FindNextBoundary()` of the manager class.

Several improvements in shape classes make the tracking algorithms much more reliable. Lego plots of radiation length can be globally computed for a given volume in the geometry (see **TGeoVolume::LegoPlot()**). Voxelization can be computed optimally in cylindrical coordinates in addition to Cartesian ones. For the time being this option is not fully stable, so it is disabled, but in future it will be used in some cases in order to improve tracking performance in geometries having this type of symmetry.

Visualization of geometry in the pad is using perspective view instead of parallel view. The view is now scaled w.r.t the absolute proportions of the drawing objects. Double-clicking volume vertices in the pad produces an animation so that the clicked volume grabs the focus of the view. Navigation can be performed using the same keys as in x3d view (see **TViewerX3D::gHelpX3DViewer**).

18 The Tutorials and Tests

This chapter is a guide to the examples that come with the installation of ROOT. They are located in two directories: `$ROOTSYS/tutorials` and `$ROOTSYS/test`.

`$ROOTSYS/tutorials`



The tutorials directory contains many example scripts. To have all examples working you must have write permission and you will need to execute `hsimple.C` first. If you do not have write permission in the directory `$ROOTSYS/tutorials`, copy the entire directory to your area. The script `hsimple.C` displays a histogram as it is being filled, and creates a ROOT file used by the other examples.

To execute it type:

```
> cd $ROOTSYS/tutorials
> root
*****
*                                     *
*           W E L C O M E  t o  R O O T           *
*                                     *
*   Version   3.05/03           25 March 2003   *
*                                     *
*   You are welcome to visit our Web site   *
*           http://root.cern.ch             *
*                                     *
*****
FreeType Engine v2.1.3 used to render TrueType fonts.
Compiled for linux with thread support.

CINT/ROOT C/C++ Interpreter version 5.15.80, Mar 17 2003
Type ? for help. Commands must be C++ statements.
Enclose multiple statements between { }.

root[0] .x hsimple.C
```

Now execute `demons.C`, which brings up the button bar shown on the left. You can click on any button to execute another example. To see the source, open the corresponding source file (for example `fit1.C`). Once you are done, and want to quit the ROOT session, you can do so by typing `.q`.

```
root[] .x demons.C
root[] .q
```

\$ROOTSYS/test

The test directory contains a set of examples that represent all areas of the framework. When a new release is cut, the examples in this directory are compiled and run to test the new release's backward compatibility.

We see these source files:

<code>hsimple.cxx</code>	Simple test program that creates and saves some histograms
<code>MainEvent.cxx</code>	Simple test program that creates a ROOT Tree object and fills it with some simple structures but also with complete histograms. This program uses the files <code>Event.cxx</code> , <code>EventCint.cxx</code> and <code>Event.h</code> . An example of a procedure to link this program is in <code>bind_Event</code> . Note that the <code>Makefile</code> invokes the <code>rootcint</code> utility to generate the CINT interface <code>EventCint.cxx</code>
<code>Event.cxx</code>	Implementation for classes <code>Event</code> and <code>Track</code>
<code>minexam.cxx</code>	Simple test program to test data fitting
<code>tcollex.cxx</code>	Example usage of the ROOT collection classes
<code>tcollbm.cxx</code>	Benchmarks of ROOT collection classes
<code>tstring.cxx</code>	Example usage of the ROOT string class
<code>vmatrix.cxx</code>	Verification program for the <code>TMatrix</code> class
<code>vvector.cxx</code>	Verification program for the <code>TVector</code> class
<code>vlazy.cxx</code>	Verification program for lazy matrices
<code>hworld.cxx</code>	Small program showing basic graphics
<code>guitest.cxx</code>	Example usage of the ROOT GUI classes
<code>Hello.cxx</code>	Dancing text example
<code>Aclock.cxx</code>	Analog clock (a la X11 <code>xclock</code>)
<code>Tetris.cxx</code>	The known Tetris game based on the ROOT graphics
<code>stress.cxx</code>	Important ROOT stress testing program

The `$ROOTSYS/test` directory is a gold mine of root-wisdom nuggets, and we encourage you to explore and exploit it. These instructions will compile all programs in `$ROOTSYS/test`:

1. If you do not have write permission in the `$ROOTSYS/test` directory, copy the entire `$ROOTSYS/test` directory to your area. The `Makefile` is a useful example of how ROOT applications are linked and built. Edit the `Makefile` to specify your architecture by changing the `ARCH` variable, for example, on an SGI machine type: `ARCH = sgikcc`
2. Now compile all programs:

```
% gmake
```

This will build several applications and shared libraries. We are especially interested in `Event`, `stress`, and `guitest`.

Event – An Example of a ROOT Application

Event is created by compiling `MainEvent.cxx`, and `Event.cxx`. It creates a ROOT file with a tree and two histograms. When running `Event` we have four optional arguments with defaults:

	Argument	Default
1	Number of Events (1 ... n)	400
2	Compression level: 0: no compression at all. 1: If the split level is set to zero, everything is compressed according to the <code>gzip</code> level 1. If split level is set to 1, leaves that are not floating point numbers are compressed using the <code>gzip</code> level 1. 2: If the split level is set to zero, everything is compressed according to the <code>gzip</code> level 2. If split level is set to 1, all non floating point leaves are compressed according to the <code>gzip</code> level 2 and the floating point leaves are compressed according to the <code>gzip</code> level 1 (<code>gzip</code> level -1). Floating point numbers are compressed differently because the gain when compressing them is about 20 - 30%. For other data types it is generally better and around 100%.	1
3	Split or not Split 0: only one single branch is created and the complete event is serialized in one single buffer 1: a branch per variable is created.	1 (Split)
4	Fill 0: read the file 1: write the file, but don't fill the histograms 2: don't write, don't fill the histograms 10: fill the histograms, don't write the file 11: fill the histograms, write the file 20: read the file sequentially 25: read the file at random	1 (Write, no fill)

Effect of Compression on File Size and Write Times

You may have noticed that a ROOT file has up to nine compression level, but here only levels 0, 1, and 2 are described. Compression levels above 2 are not competitive. They take up to much write time compared to the gain in file space. Below are three runs of `Event` on a Pentium III 650 MHz and the resulting file size and write and read times.

No Compression:

```
> Event 400 0 1 1
400 events and 19153182 bytes processed.
RealTime=6.840000 seconds, CpuTime=3.560000 seconds
compression level=0, split=1, arg4=1
You write 2.800173 Mbytes/Realtime seconds
You write 5.380107 Mbytes/Cputime seconds

> ls -l Event.root
... 19752171 Feb 23 18:26 Event.root

> Event 400 0 1 20
400 events and 19153182 bytes processed.
RealTime=0.790000 seconds, CpuTime=0.790000 seconds
You read 24.244533 Mbytes/Realtime seconds
You read 24.244533 Mbytes/Cputime seconds
```

We see the file size without compression is 19.75 MB, the write time is 6.84 seconds and the read time is 0.79 seconds.

Compression = 1: event is compressed:

```
> Event 400 1 1 1
400 events and 19153182 bytes processed.
RealTime=6.440000 seconds, CpuTime=4.020000 seconds
compression level=1, split=1, arg4=1
You write 2.974096 Mbytes/Realtime seconds
You write 4.764473 Mbytes/Cputime seconds

> ls -l Event.root
... 17728188 Feb 23 18:28 Event.root

> Event 400 1 1 20
400 events and 19153182 bytes processed.
RealTime=0.900000 seconds, CpuTime=0.900000 seconds
You read 21.281312 Mbytes/Realtime seconds
You read 21.281312 Mbytes/Cputime seconds
```

We see the file size 17.73, the write time was 6.44 seconds and the read time was 0.9 seconds.

Compression = 2: Floating point numbers are compressed with level 1:

```
> Event 400 2 1 1
400 events and 19153182 bytes processed.
RealTime=11.340000 seconds, CpuTime=9.510000 seconds
compression level=2, split=1, arg4=1
You write 1.688993 Mbytes/Realtime seconds
You write 2.014004 Mbytes/Cputime seconds

> ls -l Event.root
... 13783799 Feb 23 18:29 Event.root

> Event 400 2 1 20
400 events and 19153182 bytes processed.
RealTime=2.170000 seconds, CpuTime=2.170000 seconds
You read 8.826351 Mbytes/Realtime seconds
You read 8.826351 Mbytes/Cputime seconds
```

The file size is 13.78 MB, the write time is 11.34 seconds and the read time is 2.17 seconds.

This table summarizes the findings on the impact of compressions:

Compression	File Size	Write Times	Read Times
0	19.75 MB	6.84 sec.	0.79 sec.
1	17.73 MB	6.44 sec.	0.90 sec.
2	13.78 MB	11.34 sec.	2.17 sec.

Setting the Split Level

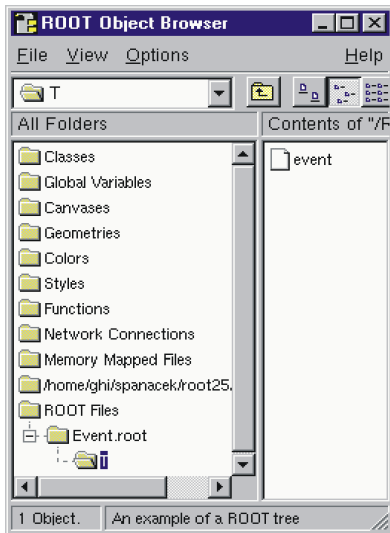

Split Level = 0:

Now we execute Event with the split parameter set to 0:

```
> Event 400 1 0 1
> root
root[] TFile f("Event.root")
root[] TBrowser T
```

We notice that only one branch is visible (event). The individual data members of the Event object are no longer visible in the browser. They are contained in the event object on the event branch, because we specified no splitting.

Split Level = 1:

Setting the split level to 1 will create a branch for each data member in the Event object. First we execute Event and set the split level to 1 and start the browser to examine the split tree:

```
> Event 400 1 1 1
> root
root[] TFile f("Event.root")
root[] TBrowser browser
```

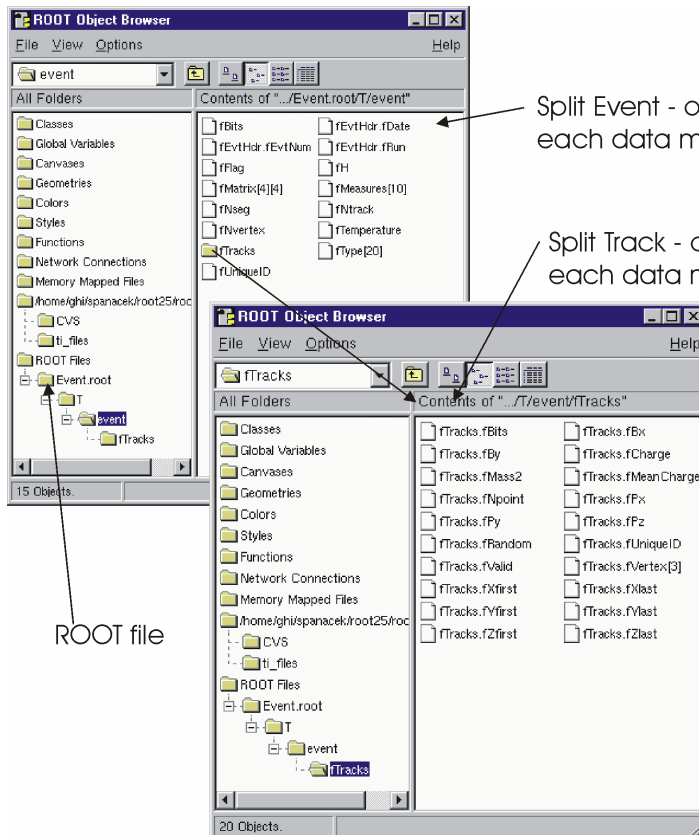

stress - Test and Benchmark

The executable `stress` is created by compiling `stress.cxx`. It completes sixteen tests covering the following capabilities of the ROOT framework.

1. Functions, Random Numbers, Histogram Fits
2. Size & compression factor of a ROOT file
3. Purge, Reuse of gaps in `TFile`
4. 2D Histograms, Functions, 2D Fits
5. Graphics & PostScript
6. Subdirectories in a ROOT file
7. `TNtuple`, Selections, `TCut`, `TCutG`, `TEventList`
8. Split and Compression modes for Trees
9. Analyze `Event.root` file of stress 8
10. Create 10 files starting from `Event.root`
11. Test chains of Trees using the 10 files
12. Compare histograms of test 9 and 11
13. Merging files of a chain
14. Check correct rebuilt of `Event.root` in test 13
15. Divert Tree branches to separate files
16. CINT test (3 nested loops) with LHCb trigger

The program `stress` takes one argument, the number of events to process. The default is 1000 events. Be aware that executing `stress` with 1000 events *will create several files consuming about 100 MB of disk space*; running `stress` with 30 events will consume about 20 MB. The disk space is released once `stress` is done.

There are two ways to run `stress`:

From the system prompt or from the ROOT prompt using the interpreter. Start ROOT with the batch mode option (-b) to suppress the graphic output.

```
> cd $ROOTSYS/test
> stress // default 1000 events
> stress 30 // test with 30 events
```

or

```
> root -b
root[] .x stress.cxx // default 1000 events
root[] .x stress.cxx (30) // test with 30 events
```

The output of `stress` includes a pass/fail conclusion for each test, the total number of bytes read and written, and the elapsed real and CPU time. It also calculates a performance index for your machine relative to a reference machine a DELL Inspiron 7500 (Pentium III 600 MHz) with 256 MB of memory and 18GB IDE disk in ROOTMARKS. Higher ROOTMARKS means better performance. The reference machine has 200 ROOTMARKS, so the sample run below with 53.7 ROOTMARKS is about four times slower than the reference machine.

Here is a sample run:

```
% root -b
root[] .x stress.cxx (30)

Test 1 : Functions, Random Numbers, Histogram Fits..... OK
Test 2 : Check size & compression factor of a Root file..... OK
Test 3 : Purge, Reuse of gaps in TFile..... OK
Test 4 : Test of 2-d histograms, functions, 2-d fits..... OK
Test 5 : Test graphics & PostScript .....OK
Test 6 : Test subdirectories in a Root file..... OK
Test 7 : TNtuple, selections, TCut, TCutG, TEventList..... OK
Test 8 : Trees split and compression modes..... OK
Test 9 : Analyze Event.root file of stress 8..... OK
Test 10 : Create 10 files starting from Event.root..... OK
Test 11 : Test chains of Trees using the 10 files..... OK
Test 12 : Compare histograms of test 9 and 11..... OK
Test 13 : Test merging files of a chain..... OK
Test 14 : Check correct rebuilt of Event.root in test 13..... OK
Test 15 : Divert Tree branches to separate files..... OK
Test 16 : CINT test (3 nested loops) with LHCh trigger..... OK
*****
* IRIX64 fnpat1 6.5 01221553 IP27
*****
stress   : Total I/O = 75.3 Mbytes, I = 59.2, O = 16.1
stress   : Compr I/O = 75.7 Mbytes, I = 60.0, O = 15.7
stress   : Real Time = 307.61 seconds Cpu Time = 292.82 seconds
*****
* ROOTMARKS = 53.7 * Root2.25/00 20000710/1022
```

guitest – A Graphical User Interface

The `guitest` example, created by compiling `guitest.cxx`, tests and illustrates the use of the native GUI widgets such as cascading menus, dialog boxes, sliders and tab panels. It is a very useful example to study when designing a GUI. Below are some examples of the output of `guitest`, to run it type `guitest` at the system prompt in the `$ROOTSYS/test` directory. We have included an entire chapter on this subject where we explore `guitest` in detail and use it to explain how to build our own ROOT application with a GUI (see Chapter [Writing a Graphical User Interface](#))

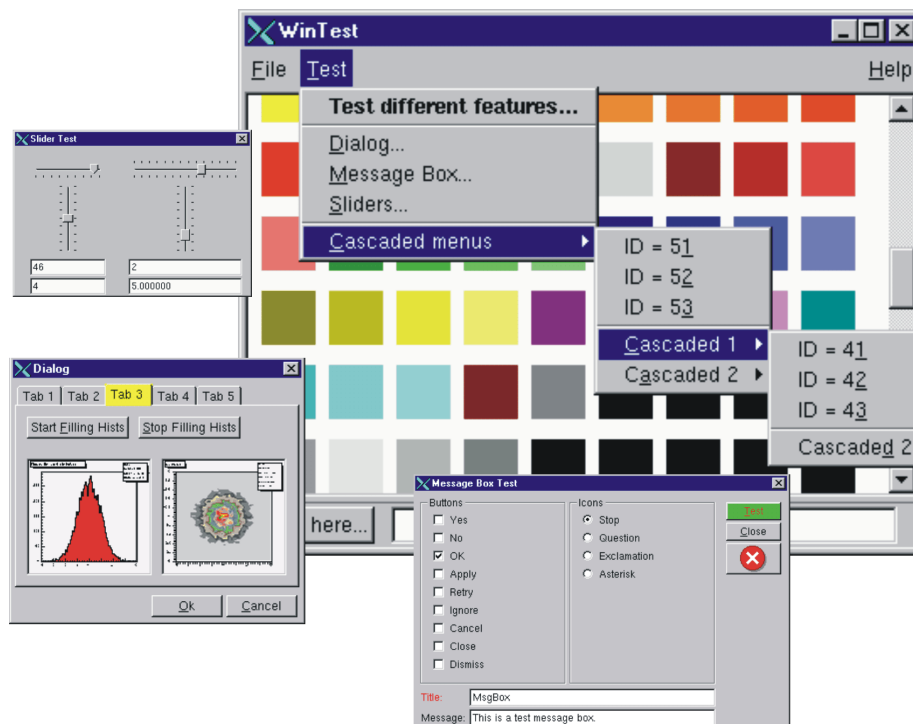

19 Example Analysis

This chapter is an example of a typical physics analysis. Large data files are chained together and analyzed using the `TSelector` class.

Explanation

This script uses four large data sets from the H1 collaboration at DESY Hamburg. One can access these data sets (277 Mbytes) from the ROOT web site at: <ftp://root.cern.ch/root/h1analysis/>

The physics plots generated by this example cannot be produced using smaller data sets.

There are several ways to analyze data stored in a ROOT Tree

- Using `TTree::Draw`:
This is very convenient and efficient for small tasks. A `TTree::Draw` call produces one histogram at the time. The histogram is automatically generated. The selection expression may be specified in the command line.
- Using the `TTreeView`:
This is a graphical interface to `TTree::Draw` with the same functionality.
- Using the code generated by `TTree::MakeClass`:
In this case, the user creates an instance of the analysis class. He has the control over the event loop and he can generate an unlimited number of histograms.
- Using the code generated by `TTree::MakeSelector`:
Like for the code generated by `TTree::MakeClass`, the user can do complex analysis. However, he cannot control the event loop. The event loop is controlled by `TTree::Process` called by the user. This solution is illustrated by the code below. The advantage of this method is that it can be run in a parallel environment using PROOF (the Parallel Root Facility).

A chain of four files (originally converted from PAW ntuples) is used to illustrate the various ways to loop on ROOT data sets. Each contains a ROOT Tree named "h42". The class definition in `h1analysis.h` has been generated automatically by the ROOT utility `TTree::MakeSelector` using one of the files with the following statement:

```
h42->MakeSelector("h1analysis");
```

This produces two files: `h1analysis.h` and `h1analysis.C`. A skeleton of `h1analysis.C` file is made for you to customize. The `h1analysis` class is derived from the ROOT class `TSelector`. The following members functions of `h1analysis` (i.e. `TSelector`) are called by the `TTree::Process` method.

- `Begin`: This function is called every time a loop over the tree starts. This is a convenient place to create your histograms.
- `Notify()`: This function is called at the first entry of a new tree in a chain.
- `ProcessCut`: This function is called at the beginning of each entry to return a flag true if the entry must be analyzed.
- `ProcessFill`: This function is called in the entry loop for all entries accepted by `Select`.

- **Terminate**: This function is called at the end of a loop on a **TTree**. This is a convenient place to draw and fit your histograms.

To use this program, try the following session.

First, turn the timer on to show the real and CPU time per command.

```
root[] gROOT->Time ();
```

Step A: create a **TChain** with the four H1 data files. The chain can be created by executed this short script `hlchain.C` below. `$H1` is a system symbol pointing to the H1 data directory.

```
{
  TChain chain("h42");
  chain.Add("$H1/dstarmb.root");
    //21330730 bytes, 21920 events
  chain.Add("$H1/dstarp1a.root");
    //71464503 bytes, 73243 events
  chain.Add("$H1/dstarp1b.root");
    //83827959 bytes, 85597 events
  chain.Add("$H1/dstarp2.root");
    //100675234 bytes, 103053 events
}
```

Run the above script from the command line:

```
root[] .x hlchain.C
```

Step B: Now we have a directory containing the four data files. Since a **TChain** is a descendent of **TTree** we can call **TChain::Process** to loop on all events in the chain. The parameter to the **TChain::Process** method is the name of the file containing the created **TSelector** class (`hlanalysis.C`).

```
root[] chain.Process("hlanalysis.C")
```

Step C: Same as step B, but in addition fill the event list with selected entries. The event list is saved to a file `elist.root` by the **TSelector::Terminate** method. To see the list of selected events, you can do `elist->Print("all")`. The selection function has selected 7525 events out of the 283813 events in the chain of files. (2.65 per cent)

```
root[] chain.Process("hlanalysis.C","fillList")
```

Step D: Process only entries in the event list. The event list is read from the file in `elist.root` generated by step C.

```
root[] chain.Process("hlanalysis.C","useList")
```

Step E: The above steps have been executed with the interpreter. You can repeat the steps B, C, and D using ACLiC by replacing `"hlanalysis.C"` by `"hlanalysis.C+"` or `"hlanalysis.C++"`.

Step F: If you want to see the differences between the interpreter speed and ACLiC speed start a new session, create the chain as in step 1, then execute

```
root[] chain.Process("hlanalysis.C+","useList")
```

The commands executed with the four different methods B, C, D and E produce two canvases shown below:

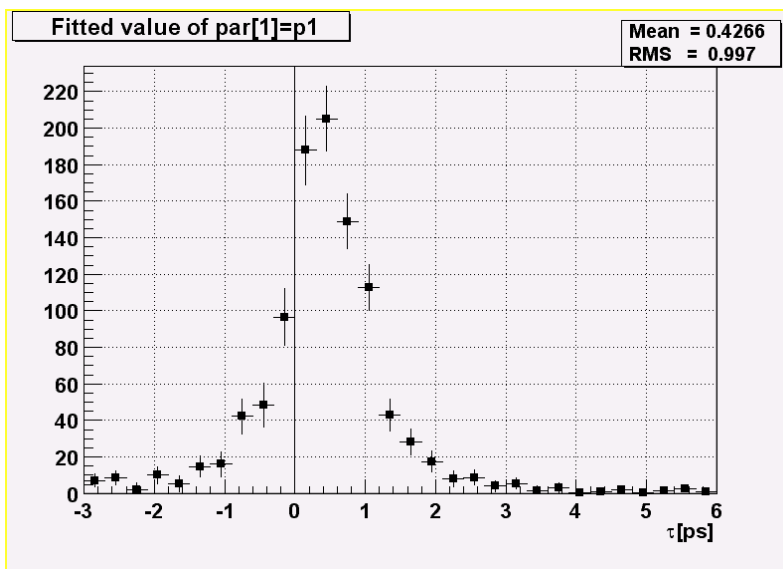
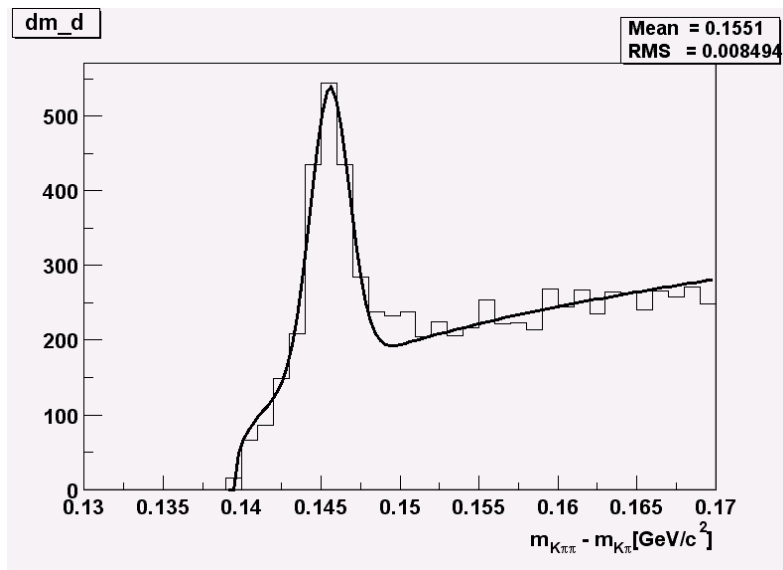

Script

This is the `hlanalysis.C` file that was generated by `TTree::MakeSelector` and then modified to perform the analysis.

```
#include "hlanalysis.h"
#include "TH2.h"
#include "TF1.h"
#include "TStyle.h"
#include "TCanvas.h"
#include "TLine.h"
#include "TEventList.h"

const Double_t dxbin = (0.17-0.13)/40; // Bin-width
const Double_t sigma = 0.0012;
TEventList *elist = 0;
Bool_t useList, fillList;
TH1F *hdmd;
TH2F *h2;

//_____
Double_t fdm5(Double_t *xx, Double_t *par)
{
    Double_t x = xx[0];
    if (x <= 0.13957) return 0;
    Double_t xp3 = (x-par[3])*(x-par[3]);
    Double_t res = dxbin*(par[0]*TMath::Power(x-0.13957,par[1])
        + par[2]/2.5066/par[4]*TMath::Exp(xp3/2/par[4]/par[4]));
    return res;
}

//_____
Double_t fdm2(Double_t *xx, Double_t *par)
{
    Double_t x = xx[0];
    if (x <= 0.13957) return 0;
    Double_t xp3 = (x-0.1454)*(x-0.1454);
    Double_t res = dxbin*(par[0]*TMath::Power(x-0.13957,0.25)
        + par[1]/2.5066/sigma*TMath::Exp(xp3/2/sigma/sigma));
    return res;
}

//_____
void hlanalysis::Begin(TTree *tree)
{
    // function called before starting the event loop
    // -it performs some cleanup
    // -it creates histograms
    // -it sets some initialization for the event list

    //initialize the Tree branch addresses
    Init(tree);

    //print the option specified in the Process function
    TString option = GetOption();

    printf("Starting hlanalysis with process option: %sn",option.Data());

    // continued..
}
```

```

//Some cleanup in case this function had already been executed
//Delete any previously generated histograms or functions

gDirectory->Delete("hdmd");
gDirectory->Delete("h2*");
delete gROOT->GetFunction("f5");
delete gROOT->GetFunction("f2");

//create histograms
hdmd = new TH1F("hdmd","dm_d",40,0.13,0.17);
h2    = new TH2F("h2","ptD0 vs dm_d",30,0.135,0.165,30,-3,6);

//process cases with event list
fillList = kFALSE;
useList  = kFALSE;
fChain->SetEventList(0);
delete gDirectory->GetList()->FindObject("elist");

// case when one creates/fills the event list
if (option.Contains("fillList")) {
    fillList = kTRUE;
    elist = new TEventList("elist","selection from Cut",5000);
}
// case when one uses the event list generated in a previous call
if (option.Contains("useList")) {
    useList = kTRUE;
    TFile f("elist.root");
    elist = (TEventList*)f.Get("elist");
    if (elist) elist->SetDirectory(0);
    //otherwise the file destructor will delete elist
    fChain->SetEventList(elist);
}
}
//
Bool_t hlanalysis::ProcessCut(Int_t entry)
{
// Selection function to select D* and D0.

//in case one event list is given in input,
//the selection has already been done.
if (useList) return kTRUE;

// Read only the necessary branches to select entries.
// return as soon as a bad entry is detected
b_md0_d->GetEntry(entry);
if (TMath::Abs(md0_d-1.8646) >= 0.04) return kFALSE;
b_ptds_d->GetEntry(entry);
if (ptds_d <= 2.5) return kFALSE;
b_etads_d->GetEntry(entry);
if (TMath::Abs(etads_d) >= 1.5) return kFALSE;
b_ik->GetEntry(entry); ik--;
//original ik used f77 convention starting at 1
b_ipi->GetEntry(entry);
ipi--;
b_ntracks->GetEntry(entry);
b_nhitrp->GetEntry(entry);
if (nhitrp[ik]*nhitrp[ipi] <= 1) return kFALSE;
b_rend->GetEntry(entry);
b_rstart->GetEntry(entry);
if (rend[ik]-rstart[ik] <= 22) return kFALSE;
if (rend[ipi]-rstart[ipi] <= 22) return kFALSE;
b_nlhk->GetEntry(entry);
if (nlhk[ik] <= 0.1) return kFALSE;
b_nlhpi->GetEntry(entry);

```

//continued..

```

if (nlhpi[ipi] <= 0.1) return kFALSE;
b_ipis->GetEntry(entry);
ipis--;
if (nlhpi[ipis] <= 0.1) return kFALSE;
b_njets->GetEntry(entry);
if (njets < 1) return kFALSE;

// if option fillList, fill the event list

if (fillList) elist->Enter(fChain->GetChainEntryNumber(entry));
return kTRUE;
}

//_____
void hlanalysis::ProcessFill(Int_t entry)
{
// Function called for selected entries only

// read branches not processed in ProcessCut

b_dm_d->GetEntry(entry);
//read branch holding dm_d
b_rpd0_t->GetEntry(entry);
//read branch holding rpd0_t
b_ptd0_d->GetEntry(entry);
//read branch holding ptd0_d

//fill some histograms

hdmd->Fill(dm_d);
h2->Fill(dm_d,rpd0_t/0.029979*1.8646/ptd0_d);
}

//_____
void hlanalysis::Terminate()
{
// Function called at the end of the event loop

//create the canvas for the hlanalysis fit

gStyle->SetOptFit();
TCanvas *c1 = new TCanvas("c1","hlanalysis analysis",
                        10,10,800,600);

c1->SetBottomMargin(0.15);
hdmd->GetXaxis()->SetTitle("m_{K#pi#pi}
                        -m_{K#pi}[GeV/c^{2}]");
hdmd->GetXaxis()->SetTitleOffset(1.4);

//fit histogram hdmd with function f5 using
//the loglikelihood option
TF1 *f5 = new TF1("f5",fdm5,0.139,0.17,5);
f5->SetParameters(1000000,.25,2000,.1454,.001);
hdmd->Fit("f5","lr");

//create the canvas for tau d0
gStyle->SetOptFit(0);
gStyle->SetOptStat(1100);
TCanvas *c2 = new TCanvas("c2","tauD0",100,100,800,600);
c2->SetGrid();
c2->SetBottomMargin(0.15);

```

//continued..

```

// Project slices of 2-d histogram h2 along X ,
// then fit each slice with function f2 and make a
// histogram for each fit parameter.
// Note that the generated histograms are added
// to the list of objects in the current directory.

TF1 *f2 = new TF1("f2",fdm2,0.139,0.17,2);
f2->SetParameters(10000,10);
h2->FitSlicesX(f2,0,0,1,"qln");
TH1D *h2_1 = (TH1D*)gDirectory->Get("h2_1");
h2_1->GetXaxis()->SetTitle("#tau[ps]");
h2_1->SetMarkerStyle(21);
h2_1->Draw();
c2->Update();
TLine *line = new TLine(0,0,0,c2->GetUymax());
line->Draw();

// save the event list to a Root file if one was
// produced
if (fillList) {
    TFile efile("elist.root","recreate");
    elist->Write();
}
}

```

20 Networking

In this chapter, you will learn how to send data over the network using the ROOT socket classes.

Setting-up a Connection

On the server side, we create a `TServerSocket` to wait for a connection request over the network. If the request is accepted, it returns a full-duplex socket. Once the connection is accepted, we can communicate to the client that we are ready to go by sending the string "go", and we can close the server socket.

```
{ // server
  TServerSocket *ss = new TServerSocket(9090, kTRUE);
  TSocket *socket = ss->Accept();
  socket->Send("go");
  ss->Close();
}
```

On the client side, we create a socket and ask the socket to receive input.

```
{ // client
  TSocket *socket = new TSocket("localhost", 9090);
  Char str[32];
  socket->Recv(str, 32);
}
```

Sending Objects over the Network

We have just established a connection and you just saw how to send and receive a string with the example "go". Now let's send a histogram.

To send an object (in our case on the client side) it has to derive from `TObject` because it uses the `Streamers` to fill a buffer that is then sent over the connection. On the receiving side, the `Streamers` are used to read the object from the message sent via the socket. For network communication, we have a specialized `TBuffer`, a descendant of `TBuffer` called `TMessage`. In the following example, we create a `TMessage` with the intention to store an object, hence the constant `kMESS_OBJECT` in the constructor. We create and fill the histogram and write it into the message. Then we call `TSocket::Send` to send the message with the histogram.

```

...
// create an object to be sent
TH1F *hpx = new TH1F("hpx", "px distribution", 100, -4, 4);
hpx->FillRandom("gaus", 1000);

// create a TMessage to send the object
TMessage message(kMESS_OBJECT);

// write the histogram into the message buffer
message.WriteObject(hpx);

// send the message
socket->Send(message);
...

```

On the receiving end (in our case the server side), we write a while loop to wait and receive a message with a histogram. Once we have a message, we call **TMessage::ReadObject**, which returns a pointer to **TObject**. We have to cast it to a **TH1** pointer, and now we have a histogram. At the end of the loop, the message is deleted, and another one is created at the beginning.

```

while (1) {
    TMessage *message;
    socket->Recv(message);
    TH1 *h = (TH1*)message->ReadObject(message->GetClass());
    delete message;
}

```

Closing the Connection

Once we are done sending objects, we close the connection by closing the sockets at both ends.

```
Socket->Close();
```

This diagram summarizes the steps we just covered:

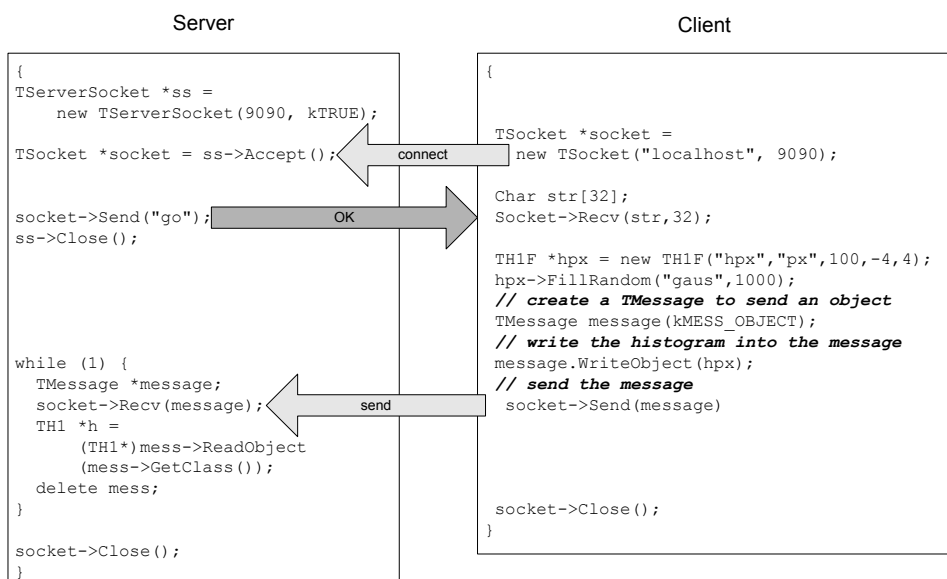

A Server with Multiple Sockets

Chances are that your server has to be able to receive data from multiple clients. The class we need for this is **TMonitor**. It lets you add sockets and the **TMonitor::Select** method returns the socket with data waiting. Sockets can be added, removed, or enabled and disabled.

Here is an example of a server that has a **TMonitor** to manage multiple sockets:

```
{
    TServerSocket *ss = new TServerSocket (9090, kTRUE);

    // Accept a connection and return a full-duplex
    // communication socket.
    TSocket *s0 = ss->Accept();
    TSocket *s1 = ss->Accept();

    // tell the clients to start
    s0->Send("go 0");
    s1->Send("go 1");

    // Close the server socket (unless we will use it
    // later to wait for another connection).
    ss->Close();

    TMonitor *mon = new TMonitor;

    mon->Add(s0);
    mon->Add(s1);

    while (1) {
        TMessage *mess;
        TSocket *s;
        s = mon->Select();
        s->Recv(mess);
    }
    ...
}
```

The full code for the example above is in `$ROOTSYS/tutorials/hserver.cxx` and `$ROOTSYS/tutorials/hclient.cxx`.

21 Writing a Graphical User Interface

The ROOT GUI classes support an extensive and rich set of widgets with the Windows 95 look and feel. The widget classes interface to the underlying graphics system via a single abstract class. Concrete versions of this abstract class have been implemented for X11 and Win32, thereby making the ROOT GUI fully cross-platform. Originally the GUI classes were based on Hector Peraza's Xclass'95 widget library <http://xclass.sourceforge.net/>

The ROOT GUI Classes

Features of the GUI classes in a nutshell:

- Originally based on the Xclass'95 widget library
- A rich and complete set of widgets
- Win'95 look and feel
- All machine dependent graphics calls abstracted via the `TVirtualX` "abstract" class
- Completely scriptable via the C++ interpreter (fast prototyping)
- Supports signal/slot event handling as pioneered by Trolltech's Qt
- Full class documentation is generated automatically (as for all ROOT classes)
- Code generation for variety of GUI's

Widgets and Frames

The ROOT GUI classes provide of set of components that allow an easy way to develop cross-platform GUI applications with a Windows look and feel.

The main widgets are:

- Simple widgets: labels, icons, push buttons, either with text or pixmaps, check buttons, radio buttons, menu bars and popup menus, scroll bars, list boxes, combo boxes, group frames, text entry widgets, tab widgets, progress bars, sliders, tool tips
- Complex widgets: shutter, toolbar, status bar, list view, list tree
- Common dialogs: File Open/Save, File Properties, Font Selection, Color Selection, About

The widgets are shown in frames:

- frame, composite frame, main frame, transient frame, group frame

Arranged by layout managers:

- horizontal layout, vertical layout, row layout, list layout, tile layout, matrix layout

Using a combination of layout hints:

- left, right, center x, center y, top, bottom, expand x, expand y, fixed offsets

Event handling by signals/slots and messaging (as opposed to callbacks):

- in response to actions widgets send messages and emit signals
- associated frames process these messages or the slot methods connected to the signals are executed

TVirtualX

The GUI classes interface to the platform dependent low level graphics system via the semi-abstract graphics base class `TVirtualX`. Currently concrete implementations exist for X11 and Win32 (MacOS X is fully supported via Apple's X11 implementation). Thanks to this single graphics interface, porting the ROOT GUI to a new platform requires only the implementation of `TVirtualX`.

Abstract Graphics Base Class TVirtualX

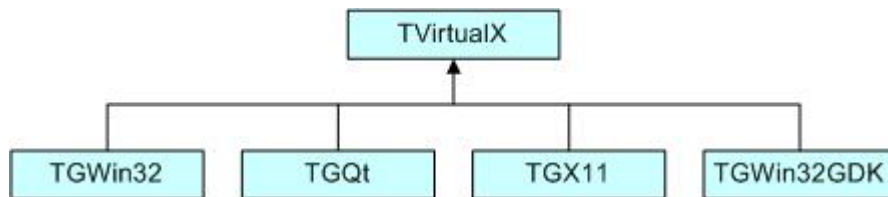

The `TGQt` interface is currently still under development.

A Simple Example

We will start with a simple example that builds a small application containing a canvas and two buttons: Draw and Exit. Its functionality will be very simple: every time you click on Draw button, the graphics of the function $\sin(x)/x$ will be drawn in randomly chosen interval in the canvas window, if you click on Exit - you close the application. This example shows the basic concepts for almost any GUI-application in ROOT and it is important to understand how it is constructed. The example program is written as a named script (see the chapter "[CINT the C++ Interpreter](#)"). Remember that the named script can be executed via

```
root[] .x example.C
```

only if the filename (without extension) and the function entry point are both the same.

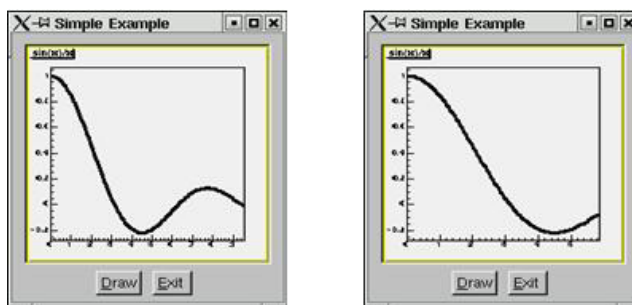

We need to say a few words about the parent-children relationship between the widgets before going through the real code. The widgets' behaviors are based on this relationship. Every parent widget is responsible for where the children are and it ensures all properties and behavior for them. For example, if you want to hide several widgets, it will be enough to hide their parent widget. Later you can show the parent and the children will appear too. Writing your code you have to specify the parent-child relationship. Usually in a child constructor the address of the parent is passed as an argument. In general frames are parents of simple widgets. In this example you will see how we organize the parent-children relationship by using frame widgets in addition to the canvas window and button widgets.

Let's now go through the code of the `example.C`.

The first lines include ROOT header files. The header file names are almost always as the class names (**TApplication**, **TF1**, **TCanvas**), but there are cases when similar classes are grouped together in one header file: all frames are declared in `TGFrame.h`, all buttons – in `TGButton.h`, etc. Our small example is based on an object of the class `MyMainFrame`.

```
new MyMainFrame(gClient->GetRoot(),200,200);
```

The first parameter `gClient->GetRoot()` makes the initial connection to the window server. It is a pointer to the root window of the screen, which is obtained from `gClient`. The next two parameters initialize the width and height of the application window in pixels. Let see what `MyMainFrame` is. The three arguments pass to the `TGMainFrame` constructor when we create the `fMain` object.

The first thing to note is the inclusion of the `RQ_OBJECT` macro in the class declaration of `MyMainFrame`. It is necessary to provide a standalone class signal/slot capability. The signal/slot communication mechanism is described in a separate chapter '[Event Processing: Signals and Slots](#)'

example.C

```
#include <TGClient.h>
#include <TCanvas.h>
#include <TF1.h>
#include <TRandom.h>
#include <TGButton.h>
#include <TGFrame.h>
#include <TRootEmbeddedCanvas.h>
#include <RQ_OBJECT.h>

class MyMainFrame {

RQ_OBJECT("MyMainFrame")

private:
    TGMainFrame          *fMain;
    TRootEmbeddedCanvas *fEcanvas;
public:
    MyMainFrame(const TGWindow *p,UInt_t w,UInt_t h);
    virtual ~MyMainFrame();
    void DoDraw();
};

MyMainFrame::MyMainFrame(const TGWindow *p,UInt_t w,UInt_t h)
{
    // Create a main frame
    fMain = new TGMainFrame(p,w,h);

    // Create canvas widget
    fEcanvas = new TRootEmbeddedCanvas("Ecanvas",fMain,200,200);
    fMain->AddFrame(fEcanvas, new TGLayoutHints(kLHintsExpandX
        | kLHintsExpandY,10,10,10,1));

    // Create a horizontal frame widget with buttons
    TGHorizontalFrame *hframe = new TGHorizontalFrame(fMain,200,40);
    TGTextButton *draw = new TGTextButton(hframe,"&Draw");
    draw->Connect("Clicked()", "MyMainFrame",this,"DoDraw()");
    hframe->AddFrame(draw, new TGLayoutHints(kLHintsCenterX,5,5,3,4));
    TGTextButton *exit = new TGTextButton(hframe,"&Exit",
        "gApplication->Terminate(0)");
    hframe->AddFrame(exit, new TGLayoutHints(kLHintsCenterX,5,5,3,4));
    fMain->AddFrame(hframe, new TGLayoutHints(kLHintsCenterX,2,2,2,2));
        // continued..
}
```

```

// Set a name to the main frame
fMain->SetWindowName("Simple Example");

// Map all subwindows of main frame
fMain->MapSubwindows();

// Initialize the layout algorithm
fMain->Resize(fMain->GetDefaultSize());

// Map main frame
fMain->MapWindow();
}
void MyMainFrame::DoDraw()
{
// Draws function graphics in randomly choosen interval
TF1 *f1 = new TF1("f1","sin(x)/x",0,gRandom->Rndm()*10);
f1->SetFillColor(19);
f1->SetFillStyle(1);
f1->SetLineWidth(3);
f1->Draw();
TCanvas *fCanvas = fEcanvas->GetCanvas();
fCanvas->cd();
fCanvas->Update();
}
MyMainFrame::~MyMainFrame()
{
// Clean up used widgets: frames, buttons, layouthints
fMain->Cleanup();
delete fMain;
}
void example()
{
// Popup the GUI...
new MyMainFrame(gClient->GetRoot(),200,200);
}

```

The **TMainFrame** class defines a top level window that interacts with the system window manager. Its method `CloseWindow()` is invoked when Alt+F4 are pressed or a window manager close/exit command is used. To terminate the application when this happens you need to override the `CloseWindow()` method and call `gApplication->Terminate(0)`.

The main frame can be considered as a container where all widgets of the application are organized with respect to their parent-child relationship. After the main frame we create `fEcanvas` – an object of class **TRootEmbeddedCanvas**. It is a quite complex widget and we will explain it in detail later. For the moment keep in mind only its main purpose – to create a **TCanvas** – the ROOT basic whiteboard for drawing and editing different graphical objects.

```
fEcanvas = new TRootEmbeddedCanvas("Ecanvas", fMain, 200, 200);
```

In the **TRootEmbeddedCanvas** constructor we pass the address of the main frame widget `fMain` as a second parameter. This pass is important because it makes `fMain` the parent of the canvas window. The first parameter `Ecanvas` is the name of the **TCanvas**, the last two parameters give the width and height of canvas window in pixels. Next step is to add `fEcanvas` to the parent frame defining its appearance inside the parent window. We use the method `AddFrame()` :

```
fMain->AddFrame(fEcanvas, new TGLayoutHints(kLHintsExpandX
                                         | kLHintsExpandY,10,10,10,1));
```

It adds the `fEcanvas` into the list of children widgets of the main frame `fMain`. The specification of how it should be placed inside the parent frame is made by the **TGLayoutHints** object.

Setting its first parameter to `kLHintsExpandX|kLHintsExpandY` we define the canvas window as expanded on x and y in the frame. The next four parameters define amounts of padding in left, right, top and bottom in pixels. This means that the canvas window will be expanded when the parent window expands, but it will keep around a frame of 10 pixels on left, right, top and 1 pixel on bottom.

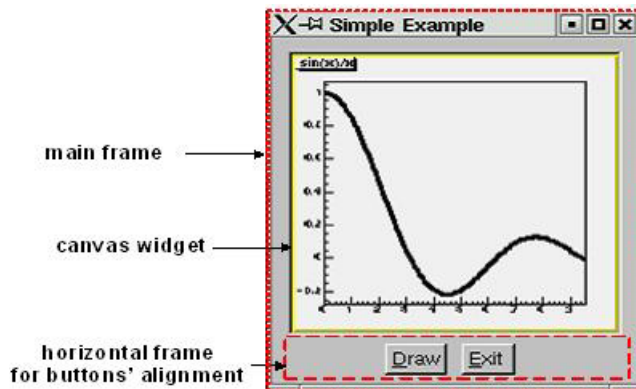

The laying out is always made with respect to the parent-children relationship. There is a special chapter presenting the different layout managers, but we will quickly introduce the concept here. The layout process will apply not to the embedded canvas window but to its parent – the main frame. A popular layout manager and the one used in this case is the vertical layout manager which arranges its widgets vertically in a column.

The next widget we create as a child of the main frame is the horizontal frame `hframe`:

```
TGHorizontalFrame *hframe=new TGHorizontalFrame(fMain,200,40);
```

The first parameter of its constructor is again the address of its parent, `fMain`. The next ones define the frame width and height in pixels. The name of the class `TGHorizontalFrame` gives a hint that a horizontal layout will apply on its children widgets. The Draw and Exit buttons will be laid out horizontally. Here are their constructors:

```
TGTextButton *draw = new TGTextButton(hframe,"&Draw");
hframe ->AddFrame(draw, new TGLayoutHints(kLHintsCenterX,5,5,3,4));

TGTextButton *exit = new TGTextButton(hframe,"&Exit",
                                     "gApplication->Terminate(0)");
hframe ->AddFrame(exit,new TGLayoutHints(kLHintsCenterX,5,5,3,4));
```

They are created as objects of the `TGTextButton` class that represent the command buttons with a text label. When you click on a command button it performs the action shown on its label. These buttons are well known as “push buttons” or just “buttons”. The parent address `hframe` is passed as first parameter. The second one defines the button label and normally indicates the action to be taken when the button is clicked. It is possible to define a hot key for the button at that point using the hot string for its label. A hot string is a string with a “hot” character underlined. This character we call the button hot key. It shows the assigned keyboard mnemonic for the button choice. Following our example, this means that you can use `Alt+D` to click on Draw button and `Alt+E` to click on Exit. There is a possibility to specify a command string as third parameter of the button constructor. We use it to assign the command `gApplication->Terminate(0)`. The application will be terminated when you click on the Exit button.

We call again `AddFrame()` to add the buttons to their parent widget giving layout hints for each of them. This time we would like to have centered buttons with an amount of 5 pixels on the left, 5 on the right, 3 on the top and 4 on the bottom.

You can feel already that the same steps are repeated three times: to create a new widget with passing a parent address as a parameter, to define layout hints for it and to add it in the parent list.

The next line is something new:

```
draw->Connect("Clicked()", "MyMainFrame", this, "DoDraw()");
```

Here we connect a signal to a slot. Whenever the draw button is clicked, it emits a signal that something has happened (it is clicked) to whom might be interesting in the outside world. The widget does not know who will use this information. On the other side of the program world there is some code which should be executed when the button is clicked. This code is called a slot. Think about slots as normal C++ functions or class methods. The line above specifies that the slot `MyMainFrame::DoDraw()` will be executed when the draw button is clicked. Our slot draws the graphics of $\sin(x)/x$ in randomly chosen interval every time the draw button sends a signal "I am clicked".

The signal/slot communication mechanism originally featured in Qt by TrollTech: <http://doc.trolltech.com/3.1/signalsandslots.html> ROOT supports its own version of signal/slot and we will return to that point in detail later.

We specified all child widgets of the horizontal frame (the Draw and Exit buttons in our case). Next, we need to add their parent frame to the main frame:

```
fMain->AddFrame(hframe, new TGLLayoutHints(kLHintsCenterX, 2, 2, 2, 2));
```

The last thing to do is to set the main window title and to make all widgets visible. Commonly in all systems windows are assigned by name to be identified by users. This name is displayed in the application's title bar and can be set by:

```
fMain->SetWindowName("Simple Example");
```

The next lines make the widgets visible. The first one maps all child frames of the top-level frame; the last one – the main frame itself, i.e. makes it appear on the screen.

```
fMain->MapSubwindows();  
fMain->Resize(fMain->GetDefaultSize());  
fMain->MapWindow();
```

The line in between has an important mission – to execute all layout specifications for the widgets before the top-level window itself is shown on the screen. We can run the named script via the CINT interpreter with the command:

```
root[] .x example.C
```

The event processing starts. If you change the state of a widget, it emits a signal and the corresponding slot is executed ensuring the functionality we want for this small example.

The steps we passed can be generalized as follows:

- Opening of the connection to the system
- Definition of main frame (top level window)
- Creation of widgets as children of the top-level frame; assign them desired properties following the steps:
 - Create a new widget passing its parent in the constructor
 - Connect widget's signals with desired slots to ensure desired functionality
 - Define widget's layout and add it to the parent list of children
- Set main window attributes
- Map all sub windows
- Initialize the layout algorithm via `Resize(GetDefaultSize())` method
- Map the main frame
- Execution of the even-processing loop

A Standalone Version

As usual a standalone program in C++ has to contain a `main()` function – the starting point for the application execution. In this case it is better to separate the program code creating a program header file `example2a.h` with the `MyMainFrame` class declaration and `example2a.cxx` – with the class methods implementation. To run our simple example as a standalone application we need to create in addition an object of class `TApplication`. It will make a correct initialization of the dictionaries if it is not yet done. It will be responsible for holding everything together and to handle all events in the application. Its environment provides an interface to the ROOT graphics system and by calling the `Run()` method the event loop starts and the application program is waiting for the user action. The application exits only if the top level window is closed. Two header files are used in addition:

`TApplication.h` – for the class `TApplication` and `TGClient.h` that is used to make initial connection to the graphics system. The class `TApplication` must be instantiated only once in any given application. The original list of argument options can be retrieved via the `Argc()` and `Argv()` methods.

`example2a.h`

```
#include <TQObject.h>
#include <RQ_OBJECT.h>

class TGWindow;
class TGMainFrame;
class TRootEmbeddedCanvas;

class MyMainFrame {

RQ_OBJECT("MyMainFrame")

private:
    TGMainFrame          *fMain;
    TRootEmbeddedCanvas *fEcanvas;
public:
    MyMainFrame(const TGWindow *p,UInt_t w,UInt_t h);
    virtual ~MyMainFrame();
    void DoDraw();
};
```

`example2a.cxx`

```
#include <TApplication.h>
#include <TGClient.h>
#include <TCanvas.h>
#include <TF1.h>
#include <TRandom.h>
#include <TGButton.h>
#include <TRootEmbeddedCanvas.h>
#include "example2a.h"

MyMainFrame::MyMainFrame(const TGWindow *p,UInt_t w,UInt_t) { ... }
MyMainFrame::~MyMainFrame() { ... }
void MyMainFrame::DoDraw() { ... }
void example() { ... }
int main(int argc, char **argv)
{
    TApplication theApp("App", &argc, argv);
    example();
    theApp.Run();
    return 0;
}
```

The class `MyMainFrame` could derive from `TGMainFrame`. The `RQ_OBJECT` macro is not needed anymore, since the functionality it provides is obtained now via inheritance from

TGMainFrame. This will reflect in the `MyMainFrame` class declaration and in the code of the `MyMainFrame::MyMainFrame` constructor as follows:

example2b.h

```
#include <TGFrame.h>

class MyMainFrame : public TGMainFrame {

private:
    TRootEmbeddedCanvas *fEcanvas;

public:
    MyMainFrame(const TGWindow *p, UInt_t w, UInt_t h);
    virtual ~MyMainFrame();
    void DoDraw();
};
```

example2b.cxx

```
#include <TApplication.h>
#include <TGClient.h>
#include <TCanvas.h>
#include <TF1.h>
#include <TRandom.h>
#include <TGButton.h>
#include <TRootEmbeddedCanvas.h>
#include "example2b.h"

MyMainFrame::MyMainFrame(const TGWindow *p, UInt_t w, UInt_t h)
    : TGMainFrame(p, w, h)
{
    // Creates widgets of the example
    fEcanvas = new TRootEmbeddedCanvas ("Ecanvas", this, 200, 200);
    AddFrame(fEcanvas, new TGLayoutHints(kLHintsExpandX |
                                        kLHintsExpandY, 10, 10, 10, 1));
    TGHorizontalFrame *hframe = new TGHorizontalFrame(this, 200, 40);
    TGTextButton *draw = new TGTextButton(hframe, "&Draw");
    draw->Connect("Clicked()", "MyMainFrame", this, "DoDraw()");
    hframe->AddFrame(draw, new TGLayoutHints(kLHintsCenterX,
                                             5, 5, 3, 4));
    TGTextButton *exit = new TGTextButton(hframe, "&Exit ",
                                           "gApplication->Terminate()");
    hframe->AddFrame(exit, new TGLayoutHints(kLHintsCenterX,
                                             5, 5, 3, 4));
    AddFrame(hframe, new TGLayoutHints(kLHintsCenterX, 2, 2, 2, 2));

    // Sets window name and shows the main frame
    SetWindowName("Simple Example");
    MapSubwindows();
    Resize(GetDefaultSize());
    MapWindow();
}
```

Widgets Overview

The word widget is a contraction of windows and gadget. Almost all GUI elements are widgets. A button is a widget, a menu item is a widget, a scrollbar is a widget, and a complete dialog box is a widget too. Some widgets may have sub widgets. For example, a dialog box can contain buttons, text fields, a combo-box, etc.

On the screen widgets look like rectangular areas with special behaviors. In terms of the object-oriented programming we can define a widget in ROOT as an object of a class deriving from `TGObject`.

This section presents all currently supported widgets in ROOT and their most useful methods. All of them can be considered as building blocks for an application, and most of them can be found in dialogs. Provided snippets of the code will give you practical guidelines where and how to use certain widgets. The macro `$ROOTSYS/tutorials/guitest.C` contains the complete source code.

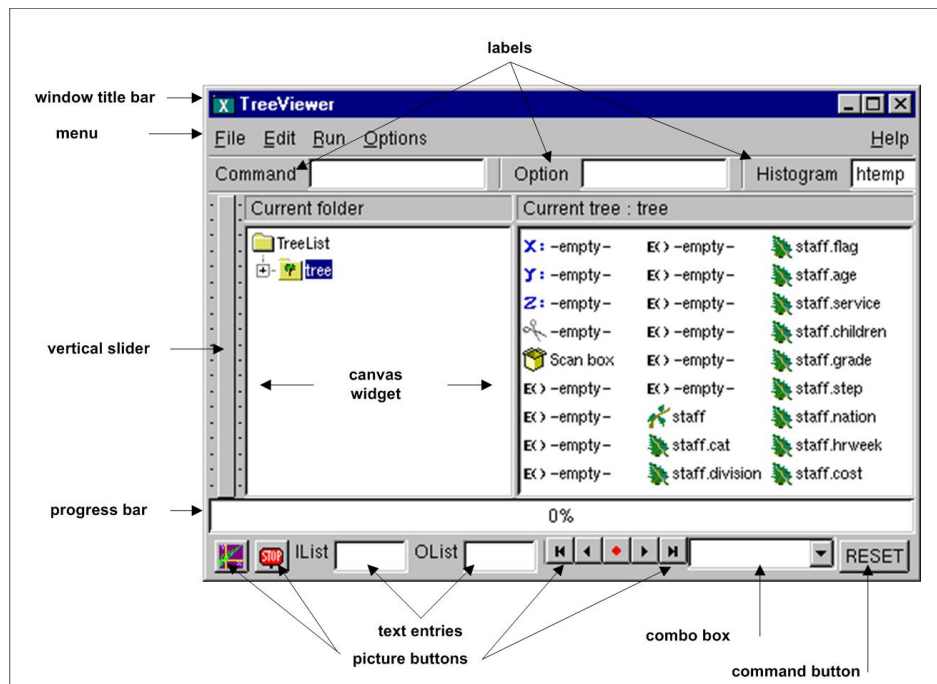

Any custom widget can be created by subclassing existing widgets. To achieve a better understanding of the widgets' properties they are separated by their type and their inheritance. As all of them inherit from `TGObject` and most from `TGWidget`, these base classes are described first.

TGObject

`TGObject` is the base class for all ROOT GUI classes. It inherits from `TObject`. The two data members of this class contain important information about X11/Win32 window identifier and the connection to the host's graphics system. Every GUI element, which derives from `TGObject` has access to the `TGClient` via the data member `fClient` of `TGObject`. `TGClient` creates the connection with the host's graphics system and sets up the complete graphics system for all widgets.

TGWidget

The widgets base class `TGWidget` is typically used as a mix-in class via multiple inheritances. Its properties are available for all deriving widgets: `TGButton`, `TGComboBox`, `TGColorPalette`, `TGColorPick`, `TGDoubleSlider`, `TGListBox`, `TGListTree`, `TGNumberEntry`, `TGScrollBar`, `TGShutterItem`, `TGSlider`, `TGTab`, `TGTextEntry`, `TGView`.

This class has four data members keeping information about the widget id – important for event processing, the window which handles the widget's events, the widget status flags and the assigned command (if there is any).

The general properties of **TGWidget** can be specified via the methods `SetFlags(Int_t flags)` and `ClearFlags(Int_t flags)`. Their names and the names of the status flags are: `kWidgetWantFocus`, `kWidgetHasFocus`, and `kWidgetIsEnabled`.

The method `Associate(const TGWindow* w)` – sets the window which handles the widget events. `SetCommand(const char* command)` – sets the command to be executed. The command string can be gathered via `GetCommand()` method. For example, the third parameter in **TGTextButton** constructor can be omitted and set later in your program, i.e. instead of:

```
TGTextButton *exit = new TGTextButton(hframe, "&Exit",
                                     "gApplication->Terminate()");
```

You will have the following the two lines:

```
TGTextButton *exit = new TGTextButton(hframe, "&Exit");
exit->SetCommand("gApplication->Terminate()");
```

The method `IsEnabled()` – returns `kTRUE` if the widget has flag `kWidgetIsEnabled` and it accepts user events. This method is very important for creating a good user interface because it allows you to disable or enable a widget depending on the situation of your application. As a standard all disabled widgets are displayed “grayed out”. `HasFocus()` – returns `kTRUE` if the widget has the input focus (i.e. flag `kWidgetHasFocus` is set). Remember that only one item in a complex widget as a dialog can have the value of `HasFocus()` sets as true. `WantFocus()` – returns `kTRUE` if the flag `kWidgetWantFocus` is set.

TGWindow

TGWindow is a ROOT GUI window base class. It inherits from **TGObject** and **TGFrame** derives from it. The application does not use it directly. It creates and registers a new window within the system. This window has common characteristics: existing parent, location, size in height and width (it has a default minimum size 1, 1 under which it cannot shrink), border with particular view, state, specific attributes. If there are no specified arguments their values will be taken from the parent. It receives events from the window system and can paint a representation of itself on the screen.

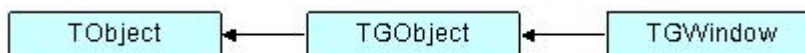

Frames

Most of the frame classes are mainly created for arranging widgets in a window. The class **TGFrame** is a subclass of **TGWindow** providing additional window characteristics and overriding some methods of **TGWindow**. It is a base class for the simple widgets as buttons, labels, etc. Its only purpose is to draw a frame around widgets that do not have a frame of their own. The main groups of **TGFrame** member functions are:

- Window's functions: `DoRedraw()`, `DeleteWindow()`, `Activate()`, etc.
- Geometry functions: `Move()`, `Resize()`, `SetSize()`, etc.
- Graphics handlers: `ChangeBackground()`, `ChangeOptions()`, etc.
- Mouse and keyboard functions: `HandleButton()`, `HandleKey()`, `HandleMotion()`, `HandleFocusChange()`, etc.
- Event handlers: `HandleEvent()`, `ProcessEvent()`, `GetSender()`, `SendMessage()`, `ProcessMessage()`, `GetLastClick()`, etc.

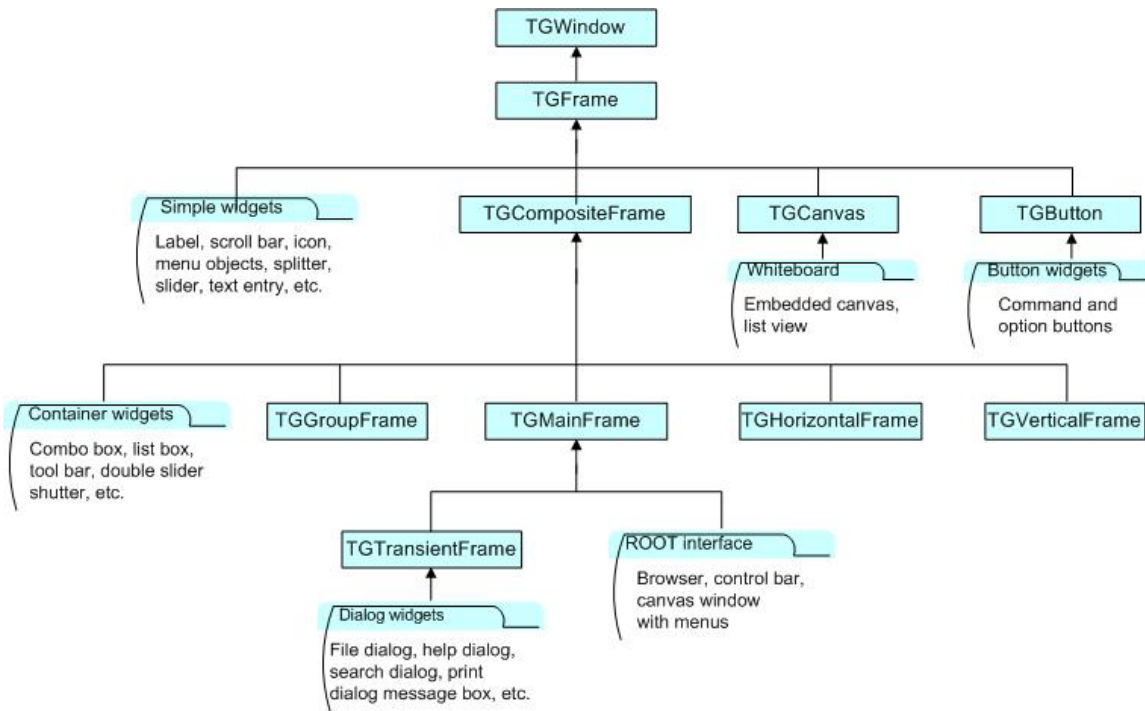

One of **TGFrame** member functions provide direct functionality; others – will be overridden by **TGFrame** subclasses to ensure particular widget's functionality. There are two constructors provided in **TGFrame** class. One creates a frame using an externally created window:

```
TGFrame(TGClient *c, Window_t id, const TGWindow *parent = 0);
```

For example, it can register the root window (called by **TGClient**), or a window created via **TVirtualX::InitWindow()** (window id is obtained by **TVirtualX::GetWindowID()** method). The other **TGFrame** constructor is:

```
TGFrame(const TGWindow *p, UInt_t w, UInt_t h, UInt_t options=0,
        ULong_t back = GetDefaultBackground());
```

The options parameter is the bitwise OR between defined frame types. Here is a short description of these types:

Frame Type	Description
kChildFrame	a frame embedded in a parent
kMainFrame	a main frame interacting with the system Window Manager
kTransientFrame	a top level dialog's frame
kVerticalFrame	a frame that layouts its children in a column
kHorizontalFrame	a frame that layouts its children in a row
kSunkenFrame	a frame with a sunken board appearance
kRaisedFrame	a frame with a raised board appearance
kFitWidth	a frame with dynamically scaled width
kFitHeight	a frame with dynamically scaled height
kFixedWidth	a frame with fixed width
kFixedHeight	a frame with fixed height
kFixedSize	= kFixedWidth kFixedHeight a frame with fixed width and height

kDoubleBorder	a frame having a double line border
kOwnBackground	a frame having own background
kTempFrame	a temporary frame shown in certain circumstances; for example, it is used for creation of tool tip widget

The method `ChangeOption(UInt_t options)` allows you to change frame options. Next example shows you how to change `kVerticalFrame` option to `kHorizontalFrame`:

```
frame->ChangeOptions((frame->GetOptions() & ~kVerticalFrame) |
                    kHorizontalFrame);
```

The class **TGCompositeFrame** is the base class of all composite widgets as a menu bar, a list box, a combo box, etc. It subclasses **TGFrame** and has in addition a layout manager and a list of child frames/widgets. There are two steps to do the design using a composite frame widget. First you put all widgets you need within this frame and assign them desired properties using `AddFrame()`, then you lay them out by the `Layout()` method according to the assigned layout manager. The method `AddFrame()` creates an instance of **TGFrameElement** class for every child widget of a composite frame. This class has three public data members: the child pointer, its layout hints, and a status variable showing if the child is visible or hidden. If no hints are specified, the default layout hints are used. Because the layout is very important part of any design we include a special section about layout management and layout hints.

You can set a layout manager for the composite frame via:

```
compFrame->SetLayoutManager(TGLayoutManager *l);
```

The child widgets cannot be added to different composite frames.

Any child frame can be removed from the parent list by:

```
compFrame->RemoveFrame(TGFrame *f);
```

You can hide or show a child frame of a composite frame using the methods: `HideFrame(TGFrame *f)` or `ShowFrame(TGFrame *f)`. You should call, for example `HideFrame(TGFrame *f)`, only after the frames have been laid out and the sub windows of the composite frame have been mapped via method `MapSubwindows()`, i.e.

```
frame->AddFrame(hFrame1, fLayout1);
frame->AddFrame(hFrame2, fLayout2);
frame->Resize(frame->GetDefaultSize()); // lays out frames
frame->MapSubwindows();                // maps subwindows
frame->HideFrame(hFrame2);              // hides frame hFrame2
frame->MapWindow();                     // maps main frame
```

The state information about a child frame can be obtained from the methods `GetState(TGFrame *f)`, `IsArranged(TGFrame *f)`, and `IsVisible(TGFrame *f)`.

The method `Cleanup()` deletes all objects of the composite frame added via `AddFrame()`. All **TGFrameElement** objects (frames and layout hints) must be unique, i.e. cannot be shared.

We already mentioned that **TGMainFrame** class defines top level windows interacting with the system window manager. It handles applications with a menu bar, toolbar, text entry fields and other widgets surrounding a central area (e.g. a canvas widget). It lays out a set of related widgets and provides the typical application main window behavior. As you can see from the figure above, it inherits from **TGCompositeFrame** and is inherited by **TGTransientFrame** and several ROOT interface classes: **TViewerX3D**, **TRootBrowser**, **TRootCanvas**, **TRootControlBar**, **TTreeView**.

To fix the size of a top level window you have to use the method **TGMainFrame::SetWMSize()**. This call tells the Window Manager that it should not

resize the window. The option `kFixedSize` works only for embedded frames like `TGCompositeFrame` and derived classes (in combination with layout hints).

The `TGVerticalFrame` and `TGHorizontalFrame` are composite frames that lay out their child frames in vertical or horizontal way in the same order as they were added and according to their hints preferences.

The `TGTransientFrame` class defines transient windows that typically are used for dialogs. They extend and complete an interaction within a limited context. Always transient frames are displayed from another window or another dialog. They may appear because of a command button being activated or a menu item being selected. They may also present automatically when an additional input and the user attention are required by a certain condition.

The `TGGroupFrame` class presents a very convenient frame which surrounds visually a group of logically connected widgets: radio buttons, related check boxes, two or more functionally related controls.

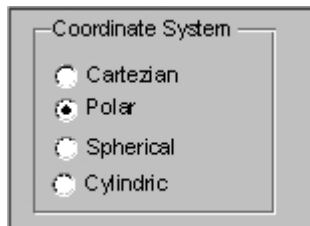

It is a composite frame with a border and a title. The title explains the purpose of the group and should be a noun or noun phrase. Here is an example taken from `guitest.C`:

```
groupFrame = new TGGroupFrame(tf, "Options", kVerticalFrame);
groupFrame->SetTitlePos(TGGroupFrame::kLeft);
```

The second line sets the title position on the left. You can change it to be centered or right aligned if you use `TGGroupFrame::kCenter` or `TGGroupFrame::kRight` as a parameter.

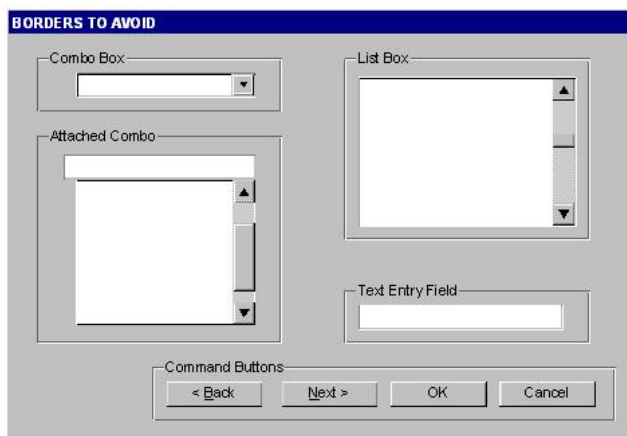

Be conservative in the use of borders because of the potential for clutter. Do not place them around single entry fields, single combo boxes, list boxes and groups of command buttons. The design of these widgets provides them with a border. The picture above provides kind of borders to avoid.

Layout Management

The layout process is an integral part of any GUI. When you create a simple message window, laying out its few buttons and text widgets is quite simple. However, this process becomes increasingly difficult if you have to implement large GUI's with many widgets that should behave properly when the GUI is resized or uses a different font type or size. Layout management is the process of determining the size and position of every widget in a container.

A layout manager is an object that performs layout management for the widgets within a container. You already know that when adding a component (child widget) to a container (parent widget) you can provide alignment hints (or rely on the default ones). These hints are used by the layout manager to correctly position the widgets in the container. The **TGLayoutManager** is an abstract class providing the basic layout functionality.

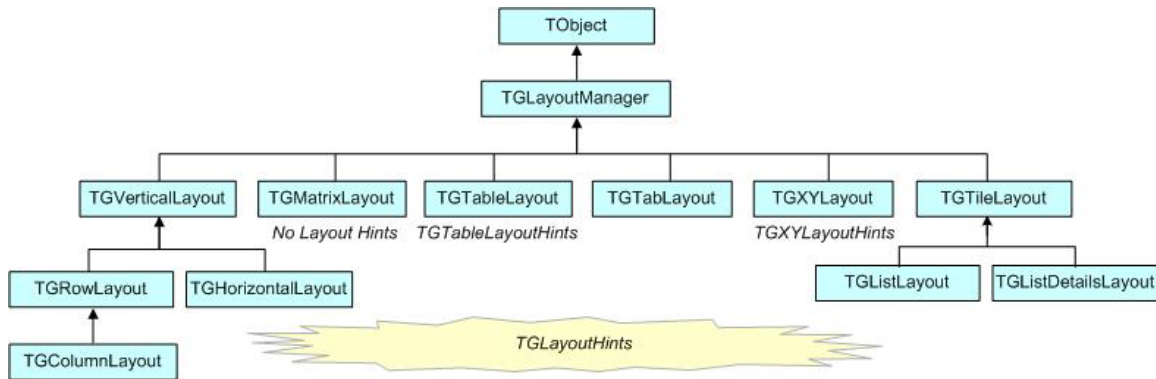

The base “container” class is **TGCompositeFrame**. You can easily change the layout manager using the `SetLayoutManager(TGLayoutManager *l)` method. Setting the proper layout manager for each container is the first step you have to do. The container uses that layout manager to position and size the components before they are painted. ROOT currently provides the layout managers shown on the picture above.

The next important step is to provide hints about every widget in the container, i.e. to provide positions and right amount of space between the components. The **TGLayotHints** objects set hints by specifying the white space in pixels around every widget.

Let’s see an example with five buttons. First you put them in a container, assign them desired properties, and then you lay them out according to the layout manager. This process can be repeated: you go back and add, remove or change some of the widgets and lay them out again.

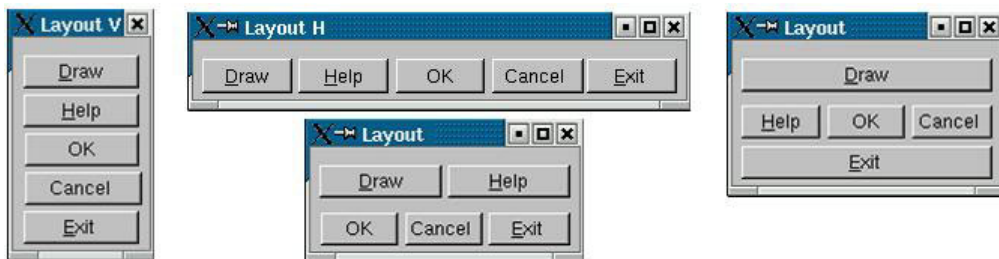

Once created, you can consider these widgets as elementary objects even though they are compound ones. The pictures above present four different layouts of five buttons. The first one shows laid out vertically buttons. Almost everywhere you can find this vertical orientation. Looking at dialogs you see that often they consist of number of rows laid out below each other. Some of the rows could have an internal vertical structure as well. The second picture shows the same buttons laid out horizontally – the next common orientation. The other two show different layouts based on mixed use of the vertical and horizontal orientation. You might recognize their pattern: two (third picture) and three (last picture) rows that are vertically laid out.

As we already explained the layout process is always applying to a container. It will be enough to define the container frame with vertical or horizontal layout to have buttons as in the first and second pictures.

To design them in several rows we need to use additional frames as invisible containers: two horizontal frames, children of a vertical parent frame; or one horizontal frame laid out vertically with the Draw and Exit buttons. For widgets in a group it is obvious to use a vertical layout.

The layout hints data member of `TGLayoutHints` is the bit wise OR between the hints:

<i>Hints</i>	<i>Description</i>
<code>kLHintsNoHints</code>	no specified layout hints, the default ones will be used
<code>kLHintsLeft</code>	specifies the frame position to the left of the container frame after other frames with the same hint into the list
<code>kLHintsCenterX</code>	specifies the frame position centered horizontally (with vertical containers only)
<code>kLHintsRight</code>	specifies the frame position to the right of the container frame before any other laid out frames with the same hint into the list
<code>kLHintsTop</code>	specifies the frame position to the top of the container frame, below any laid out frames with the same hint
<code>kLHintsCenterY</code>	specifies the frame position centered vertically (with horizontal containers only)
<code>kLHintsBottom</code>	specifies the frame position to the bottom of the container frame, above any laid out frames with the same hint
<code>kLHintsExpandX</code>	specifies the frame to be expanded up to the width of the container frame. If the container frame is a vertical frame – it will fit the whole width. If it is a horizontal frame – after the positioning of all frames the available “free” width space is shared between the frames having this hint
<code>kLHintsExpandY</code>	specifies the frame to be expanded up to the height of the container frame. If the container frame is a horizontal frame – it will fit the whole height. If the container frame is a vertical frame – after the arrangement of all frames the available “free” height space is shared between the frames having this hint
<code>kLHintsNormal</code>	= <code>kLHintsLeft</code> <code>kLHintsTop</code> – default hints

Layout policy:

Child frames never modify their container frame. The container frame can (or cannot) adapt its size in the layout process. It can show all or a part of its frames. Every `TGFrame` object has a default minimum size (1, 1) assured by `TGWindow`.

Event Processing: Signals and Slots

Event handling covers the interaction between different objects and between the user and the objects in an application. There are two general ways for the user to interact with an application: the keyboard and the mouse. The Graphical User Interface is as a bridge between the user and the program - it provides methods to detect the user actions and instruments that do something as a reaction of these actions. The user communicates with an application through the window system. The window system reports interaction events to the application. The application in turn forwards them to the currently active window. The objects/widgets receive the events and react to them according to the application functionality.

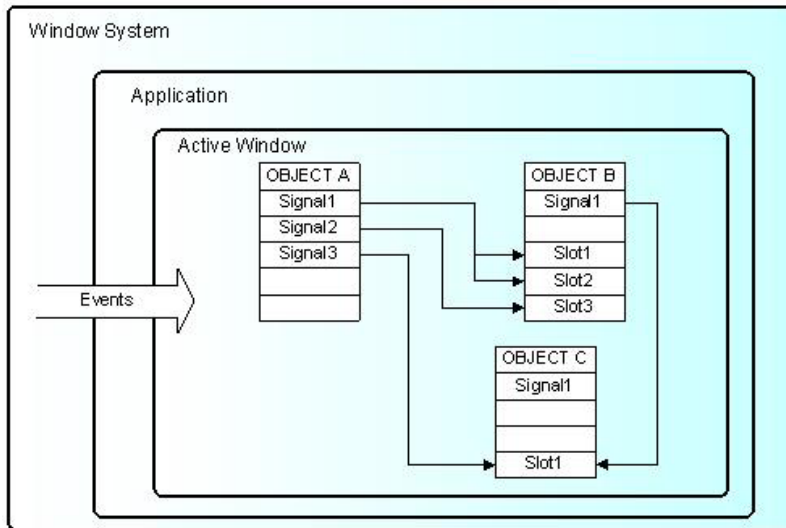

The signals/slot communication mechanism is an advanced object communication concept; it largely replaces the concept of callback functions to handle actions in GUI's. Signals and slots are just like any object-oriented methods implemented in C++. The objects are the instances of classes that don't know anything about each other. They interact and allow method calls of other object's methods. The idea is simple: any object can send out (emit) a signal in certain situations saying that something happened. This is all it does to communicate and it does not know whether anything is interested in this information. On the other side there might be an object waiting for that signal and ready to react to it. This object disposes of special instruments to listen to the sent out signals. To have a communication we need a message transmission between the objects. In this simple example we use signals and slots. The code of the method `TGButton::Clicked()` is:

```
virtual void Clicked() { Emit("Clicked()"); } // *SIGNAL*
```

I.e. any button emits the signal `Clicked()` any time someone clicks on it. As you can see this method is virtual and could be overridden if you need to. In our simple example we call the `Connect()` method to connect the `Clicked()` signal of `Draw` button with `MyMainFrame::DoDraw()`:

```
draw->Connect("Clicked()", "MyMainFrame", this, "DoDraw()");
```

In the same way we can connect to the signal `Clicked()` of the `Exit` button with the system call `gApplication->Terminate(0)`. We declare a new slot `DoExit()`, implement it to invoke the termination call and associate this slot with the signal `Clicked()` of the `Exit` button. The code of `example.C` can be changed as follows:

```
public:
    ...
    void DoExit(); // a new slot is added
}
void MyMainFrame::DoExit()
{
    gApplication->Terminate(0);
}

MyMainFrame::MyMainFrame(const TGWindow *p, UInt_t w, UInt_t h)
{
    ...
    TGTextButton *exit = new TGTextButton(hframe, "&Exit ");
    // connects signal Clicked() with slot DoExit()
    exit->Connect("Clicked()", "MyMainFrame", this, "DoExit()");
    ...
}
```

Here is an abstract view of the signal/slots connections in `example.C`:

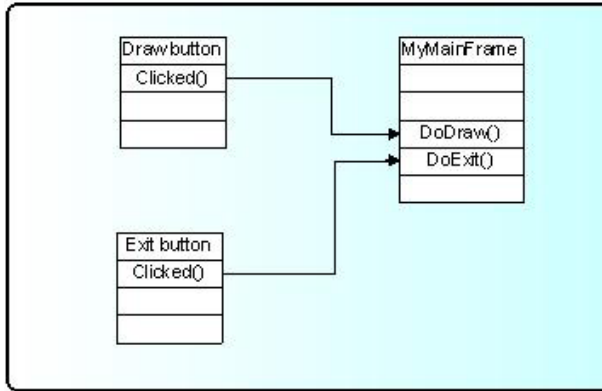

To benefit from this mechanism your classes must inherit from `TQObject` or otherwise the class definition must start with `RQ_OBJECT("ClassName")` macro. This macro allows the signals/slots communication mechanism to be applied between compiled and interpreted classes in an interactive ROOT session without having the class derive from `TQObject`. Every signal method declaration is followed by a comment `/*SIGNAL*/`. Only instances of a class that defines a signal or instances of its subclasses can emit the signal. The ROOT implementation of a popular example presenting signals and slots is the next. Let's have a minimal class declaration:

```

class MyClass {
private:
    Int_t fValue;
public:
    MyClass() { fValue=0; }
    Int_t GetValue() const { return fValue; }
    Void SetValue(Int_t);
};
  
```

It will become the following as interpreted:

```

class MyClass {
    RQ_OBJECT("MyClass")

private:
    Int_t fValue;
public:
    MyClass() { fValue=0; }
    Int_t GetValue() const { return fValue; }
    Void SetValue(Int_t); // *SIGNAL*
};
  
```

Both class declarations have the same data member and public methods to access the value. By placing the `RQ_OBJECT("MyClass")` macro inside the `MyClass` body (`MyClass` is not inherited from `TQObject`) we allow this class to use the signal/slot communication. Any instance of this class can tell the outside world that the state of its data member has changed by emitting a signal `SetValue(Int_t)`. A possible implementation of `MyClass::SetValue()` can be:

```

void MyClass::SetValue(Int_t v)
{
    if (v != fValue) {
        fValue = v;
        Emit("SetValue(Int_t)", v);
    }
}
  
```

The line `Emit("SetValue(Int_t)", v)` activates the signal `SetValue(Int_t)` with argument `v`. You can use any of the methods

TQObject::Emit("full_method_name", arguments) to emit a signal. We create two instances of **MyClass** and connect them together:

```
MyClass *objA = new MyClass();
MyClass *objB = new MyClass();
objA->Connect("SetValue(Int_t)", "MyClass", b, "SetValue(Int_t)");
objB->SetValue(11);
objA->SetValue(79);
objB->GetValue(); // the value is 79
```

By calling the method `objA->Connect()`, `objA` connects its signal "SetValue(Int_t)" to the "MyClass::SetValue(Int_t)" method (slot) of `objB`. Next, when you call `objA->SetValue(79)` object `objA` emits a signal which `objB` receives and `objB->SetValue(79)` is invoked. It is executed immediately, just like a normal function call. `objB` will emit the same signal in turn, but nobody is interested in this signal, since no slot has been connected to it. Signals are currently implemented for all ROOT GUI classes, event handlers (**TFileHandler**, **TSignalHandler**, etc.), timers (**TTimer**) and pads (**TPad**, **TCanvas**, etc.). To find all defined signals you just do:

```
grep '*SIGNAL*' $ROOTSYS/include/*.h
```

As a programmer you build the sender-receiver part of object connections using the **TQObject::Connect()** method. You can connect one signal to many different slots. The slots will be activated in order they were connected to the signal. You can change this order using the methods `LowPriority()` and `HightPriority()` of **TQObject**. Also, many signals can be connected to one slot of a particular object or a slot can be connected to a signal for all objects of a specific class. It is even possible to connect a signal directly to another signal – this will emit the second signal immediately after the first one is emitted.

All signals and slots are normal class methods and can take any number of arguments of any type. The common methods of **TQObject** that activate a signal with any number and type of parameters are:

```
Emit(signal_name, param);
```

With no parameters `param` the method will be:

```
ApplyButton->Emit("Clicked()");
```

`param` can be a single parameter or an array of `Long_t` parameters as it is shown below:

```
TQObject *processor; // data processor
TH1F *hist; // filled with processor results
...
processor->Connect("Evaluated(Float_t, Float_t)", "TH1F", hist,
                 "Fill(Axis_t x, Axis_t y)");
...
Long_t args[2];
args[0] = (Long_t)processor->GetValue(1);
args[0] = (Long_t)processor->GetValue(2);
...
processor->Emit("Evaluated(Float_t, Float_t)", args);
...
```

To use signals and slot you need something that brings them together. The class **TQObject** has several methods creating sender-receiver connections. Some of them are static and can be called without having an instance of the class. The ROOT implementation of signals and slots allows connections to any known CINT object. The class name parameter in the `Connect()` methods must be a class with a dictionary (interpreted classes have an implicit dictionary).

```
TGButton *myButton;
TH2      *myHist;
...
TQObject::Connect(myButton, "Clicked()", "TH2", MyHist, "Draw(Option_t*)");
```

You can replace it with 0 (zero) and in this case the slot string defines a global or interpreted function name. The receiver parameter should be zero too. For example:

```
TQObject::Connect(myButton, "Clicked()", 0, 0, "hsimple()");
```

To make a single connection from all objects of a class you should write:

```
TQObject::Connect("Channel", "AlarmOn()", "HandlerClass",
                 handler, "HandleAlarm()");
```

The first argument specifies the class name Channel. The signal AlarmOn() of any object of the class Channel is connected to the HandleAlarm() method of the handler object of the class HandlerClass.

In example.C we have used the not-static Connect() method:

```
Bool_t Connect(const char *signal, const char *receiver_class,
              void *receiver, const char *slot);
```

It needs to know four things: the signal that should be connected, the receiver class, the object that will receive the signal, and the slot that will be connected to the signal. Because this method is non-static we can write this as a receiver parameter.

In all methods you have to specify the signal and the slot with their names and parameter types. Do not write values instead of types in that place. It is possible to pass a parameter by value to a slot method in the following way:

```
Connect(myButton, "Pressed()", "TH1", hist, "SetMaximum(=123)");
Connect(myButton, "Pressed()", "TH1", hist, "Draw(=\\"LEGO\\")");
```

As you see the parameter's value is preceded by the equation symbol (=).

You have the possibility to destroy a signal/slot connection by using Disconnect() methods. There are three ways to do this: 1/ to destroy all connections to an object's signals; 2/ to destroy all connections to a particular object's signal; 3/ to detach an object from a specific receiver:

```
Disconnect(myObject); // case 1
Disconnect(myObject, "mySignal"); // case 2
Disconnect(myObject, 0, myReceiver, 0); // case 3
```

Three parameters of these methods could be replaced by 0. The meaning in these cases would be "any signal", "any receiving object", "any slot of the receiving object", i.e. 0 is used as a wildcard. The sender parameter cannot be 0, because you can disconnect signals from one given object. If the signal parameter is 0, the receiver and the slot are disconnected from any signal. Giving the name of the signal you disconnect this signal.

In addition to all Qt features the ROOT version of signals/slots gives you the possibility to connect slots to a class. The slots will be executed every time the specified signal is emitted by any object of this class. A slot can have default arguments and it can be either a class method or stand-alone function (compiled or interpreted).

The method `TQObject::HasConnection(signale_name)` checks if there is an object connected to this signal and returns true if it is the case. Using `TQObject::NumberOfConnections()`, `TQObject::NumberOfSignals()` you can check how many signals or connections has the object.

The rules for using signals/slots mechanism in a standalone executable program do not differ from what was described previously. Let's remind that

- a slot can be any class method with a generated CINT dictionary
- a slot can be a function with a dictionary

Detailed information how to generate a dictionary can be found on <http://root.cern.ch/root/Cint.phtml?ref>

The following example demonstrates how to use signals/slots mechanism in a standalone executable program on linux platform with the gcc compiler.

tst.C

```
#include <TQObject.h>
#include <RQ_OBJECT.h>

class A
{
  RQ_OBJECT("A")

private:
  Int_t fValue;
public:
  A():fValue(0) { }
  ~A() { }
  void SetValue(Int_t value); // *SIGNAL*
  void PrintValue() const { printf("value=%d\n",fValue); }
};

void A::SetValue(Int_t value) // Set new value
{
  // Emit signal "SetValue(Int_t)" with a single parameter

  if(value!=fValue) {
    fValue=value;
    Emit("SetValue(Int_t)",fValue);
  }
}

// Main program
#ifdef STANDALONE

int main(int argc, char **argv)
{
  A* a = new A();
  A* b = new A();

  a->Connect("SetValue(Int_t)","A",b,"SetValue(Int_t)");

  printf("\n***** Test of SetValue(Int_t) signal *****\n");
  b->SetValue(10);
  printf("\n\t***** b before *****\n");
  b->PrintValue();
  a->SetValue(20);
  printf("\t***** b after a->SetValue(20) *****\n");
  b->PrintValue();
  return 0;
}
#endif
```

ACLiC simplifies this procedure and allows the dictionary generation by:

```
root[] .L tst.C++
```

It will create the shared library `tst_C.so`.

The next line will create an executable:

```
g++ -o tst tst.C `root-config --cflags --libs` ./tst_C.so -DSTANDALONE
```

The library `tst_C.so` is a dynamically loaded library and should be located in `$LD_LIBRARY_PATH`. The current working directory should be added to `$LD_LIBRARY_PATH` via:

```
export LD_LIBRARY_PATH=$LD_LIBRARY_PATH:./
```

To run it, you just do:

```
./tst
```

The Widgets in Details

Buttons

Buttons are a popular group of widgets designed to provide specific interfaces for user interaction. `TGButton` is an abstract class defining the general button behavior: width, height, state, its group, tool tip text, etc.

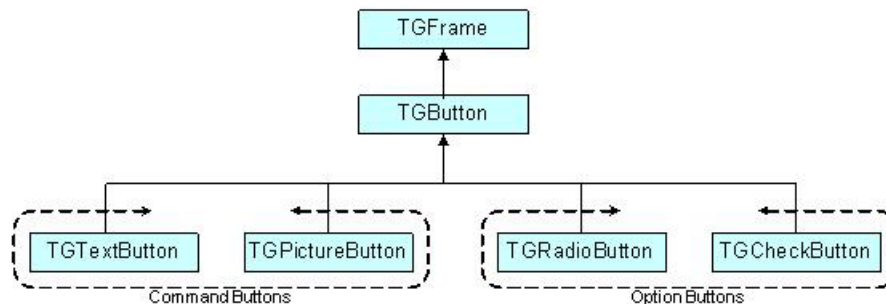

There are two main groups of buttons: command buttons with a text or graphics inside that indicate the action to be accomplished and option buttons well known as radio and check buttons that select or change properties. The first group is presented in ROOT by `TGPictureButton` and `TGTextButton` classes. They yield an action as soon as they are clicked. It can be opening/closing a dialog box or invoking a specific function in an application. Remember the Draw button from the example. The radio and check buttons from the second group are used to select an option. There is a visual difference between these two groups: the text buttons appear “pressed in” only while they are clicked, while the radio and check buttons change their appearance when they are selected and keep that appearance afterwards.

A text button is represented by the class `TGTextButton`. We already used its constructor in the example. The button label indicates the action to be taken when the button is selected or pressed. The text can be a hot string defining a hot key (known as shortcut key also) for this selection. The hot key is an underlined character in a button label that shows the assigned keyboard mnemonic for its choice. A button that prompts more information for users has the label generally followed by ellipsis (...).



As we saw the hot strings `"&Draw"` and `"&Exit"` define the text labels “Draw” and “Exit” and keyboard mnemonics `Alt+D`, `Alt+E` for their selection. The letter D and E appear underlined on the screen. All text buttons should have a unique shortcut key with the exception of OK and Cancel.

These buttons are usually placed within a window to provide fast access to frequently used or critical commands. They help in situations where a command is not available through the menu bar. You already know that a command string can be passed in the text button via the constructor:

```
TGTextButton(const TGWindow *p,const char *s,const char *cmd,
             Int_t id,GContext_t norm,FontStruct_t font,UInt_t options);
```

A button label can be changed by `SetText(new_label)`. There are important guidelines to be followed about a button label. The text has to provide a meaningful description of the performed action. The single-word label should be used whenever possible, only two-three words for clarity, if necessary. Do not number labels. Always follow all platform presentation and usage guidelines for standard button functions. Let's remember a few standard names and definitions of well known buttons:

OK - any changed information in a window is accepted and the window is closed;
Cancel – closes window without implementing submitted changes;
Reset – resets defaults and cancels any changed information that has not be submitted;
Apply – any changed information is accepted and again displayed in the window that remains open;
Close – closes the window;
Help – opens online Help.

Below are examples of text buttons. Note the two placement methods. The first example should be used when there are one to three command buttons; the second one when there are more than three buttons.

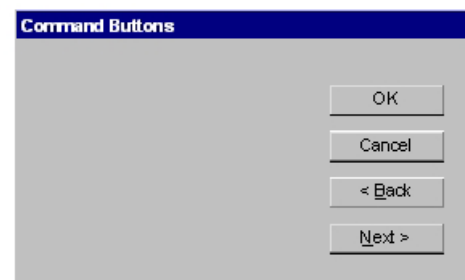
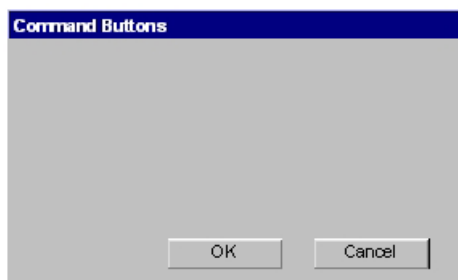

Picture buttons are usually rectangular in shape with an icon or graphics label. These buttons may appear alone or placed in a group at the window's top or side. They are most frequently used to quickly access commands, many of which are normally accessed through the tool bar. For example, the picture buttons below can be used to provide different styles of a histogram drawing.



Here is the example how to create the first button:

```
TGPictureButton *fPicture = new TGPictureButton(parent,
                                               gClient->GetPicture("h1_s.xpm"), 11);
```

The picture of file `h1_s.xpm` is used in the button. All `.xpm` files are located in the directory `$ROOTSYS/icons`. You can assign a command directly as a parameter of the picture button constructor. The picture of `TGPictureButton` can be changed by:

```
fPicture->SetPicture("h2_s.xpm");
```

The advantage of command buttons is that they are always visible, providing a reminder of their existence. They can be inscribed with a meaningful description of what they do by `TGToolTip("Some describing text")`. Their activation is much easier and faster than using a two-step menu bar/pull-down sequence. The only disadvantage of the text and picture buttons is that they consume considerable screen space if they are many. Having no more than six command buttons per window or dialog box helps to appropriately balance the application's effectiveness, its real efficiency, and the operational simplicity.

The classes **TGRadioButton** and **TGCheckBoxButton** present the option buttons in ROOT. Like the text buttons, they have text or hot string as a label. Radio buttons are grouped in logical sets of two or more and appear with a text label to the right. The choices are mutually exclusive and only one setting is permitted at one time. They represent visually all alternatives and it is easy to access and compare choices. They facilitate the situations where all alternatives cannot be easily remembered or where displaying the alternatives together helps to understand and select the proper choice. It is very useful to provide a default setting whenever it is possible. When it is not possible to establish a default setting because of the nature of the information, it is better to leave all radio buttons blank.

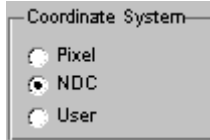

A columnar orientation is the preferred manner of radio buttons presentation. If the vertical space on the window is limited, they can be oriented horizontally. Selection choices should be organized logically in groups. Here is the example that produces the image above:

```
br = new TGButtonGroup(p, "Coordinate system", kVerticalFrame);
fR[0] = new TGRadioButton(bg, new TGHotString("&Pixel"));
fR[1] = new TGRadioButton(bg, new TGHotString("&NDC "));
fR[2] = new TGRadioButton(bg, new TGHotString("&User "));
fR[1]->SetState(kButtonDown);
br->Show();
```

It is enough to change **kVerticalFrame** to **kHorizontalFrame** in **TGButtonGroup** constructor and you will have radio buttons aligned horizontally:

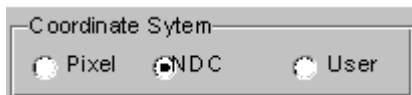

The class **TGButtonGroup** will help you to organize button widgets in a group. There is no need to call **AddFrame()** since the buttons are added automatically with a default layout hint to their parent by **TGButtonGroup::Show()** as shown above.

The example above shows that. The buttons in the group have assigned identifiers. Any button in a group emits a **Clicked()** signal with this identifier when it is clicked. This giving an ideal solution to connect several **Clicked()** signals to one slot.

An exclusive button group switches off all toggle buttons except the selected one. The group is by default non-exclusive but its entire radio buttons will be mutually exclusive.

TGHButtonGroup and **TGVButtonGroup** are convenience classes that offer you a thin layer on top of **TGButtonGroup**. **TGHButtonGroup** organize button widgets in a group of one horizontal row, **TGVButtonGroup** in a group of one column. You can also organize buttons in rows and columns using the provided constructor and **TGMatrixLayout**.

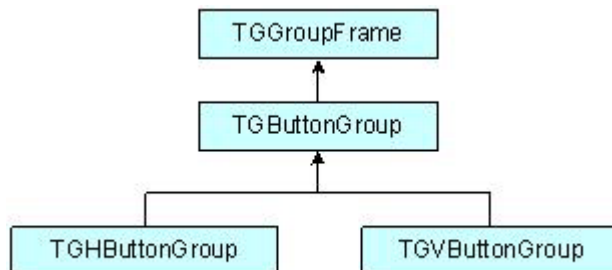

Do not use a radio button to indicate the presence or absence of a state – use a check box instead.

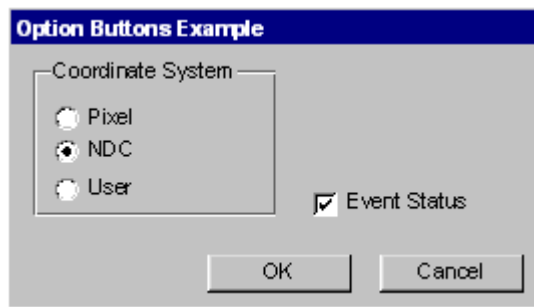

To have the check button “Event Status” and to set it as selected we need to write:

```
TGCheckButton *estat = new TGCheckButton(p, "Event Status", 1);
estat->SetState(kButtonDown);
```

Check boxes show the selected choices and any number of them can be selected, including none. Their proper usage is for setting attributes, properties or values; also for data or choices that are discrete, small and fixed in number, not easily remembered. With check boxes all alternatives are visible: it is easy to access and compare choices because they can all be seen together. Each option acts as a switch and can be either “on” or “off”. It is never changed in contents. Checkboxes differ from radio buttons in that they permit selection of more than one alternative. Each box can be switched on or off independently. These buttons can be used alone or grouped in sets. It is good practice to provide default settings for check boxes whenever it is possible.

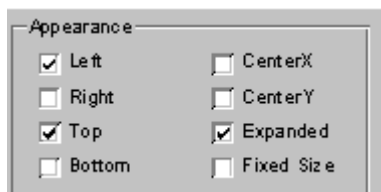

This can be done by:

```
SetState(EButtonState state)
```

The parameter `state` can be one of `kButtonUp`, `kButtonDown`, `kButtonEngaged`, `kButtonDisabled`.

Check boxes can be used to affect other controls. The contents of a list can, for example, be filtered by setting a check box. In any case, use a check box only when both states of a choice are clearly opposite and unambiguous. If opposite states are not clear, it is better to use two radio buttons.

Choice description, i.e. check box label, must be clear, meaningful, fully spelled out, and displayed in mixed-type text. Whenever the use of a given button is inappropriate, for whatever reason, that button should be disabled:

```
button->SetState(kButtonDisabled);
```

Never make a button appear and disappear.

In general, option buttons should not offer more than eight choices. If the number of choices exceeds this maximum, it is better to use a multiple selection list box.

The method `IsToggleButton()` gives the information whether a radio button or a check button is selected. An option button can be set or unset via its method `PSetState(EButtonState state)`.

The method `HandleKey(event)` is called when the defined hotkey is hit for any button. It sets the selected option button or clicks the selected text button and invokes its defined action.

Menus

Menus provide a list of commands or options helping the user to select and to perform a task. The menu system classes are `TGMenuBar`, `TGMenuItem`, `TGPopupMenu`, and `TGMenuEntry`.

The `TGMenuEntry` derives from `TObject`, the others – as is shown on the next page:

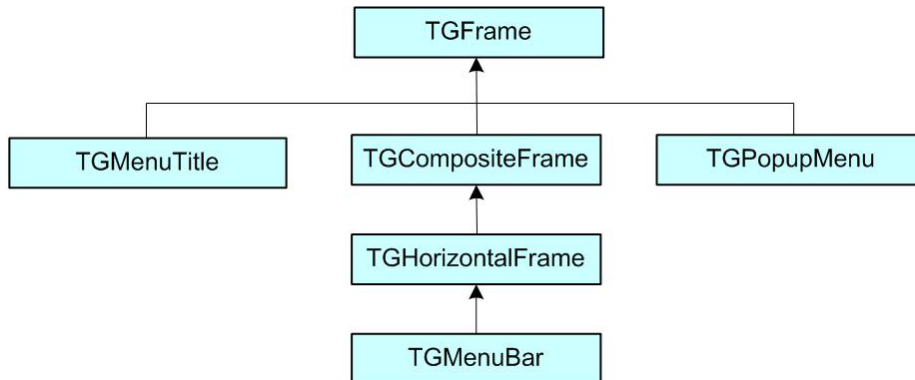

The `TGMenuBar` class implements a menu bar widget. It is used to specify and provide access to common and frequently used application actions described in menu titles, implemented by `TGMenuItem` class. The menu bar is the highest-level of the menu system and it is a starting point for all interactions. Also, it is always visible and allows using the keyboard equivalents. The geometry of the menu bar is automatically set to the parent widget, i.e. the menu bar automatically resizes itself so that it has the same width as its parent (typically `TGMainFrame`).

The menu bar is as a container for its menus – objects of the type `TGPopupMenu`. Popup menus can appear in a menu bar. They can be a sub-menu of another popup menu (cascading menus) or can be standalone (as a context menu). They are made of one or more menu items choices. When displayed, the menu items are arranged in a vertical list. Usually they correspond to actions (e.g. *Open*). These items can be labeled with text, graphics or a combination of both. Each of them should have a character defined as its unique key for access. Grouped logically by their functionality, they are separated visually by menu separators in groups. For example, The *File* menu is a common menu title for tasks that apply to a file, as *Open, Save, Close, Print...*

```
// a popup menu
fMenuFile = new TGPopupMenu(gClient->GetRoot());

// adding menu entries
fMenuFile->AddEntry("&Open...", M_FILE_OPEN);
fMenuFile->AddEntry("&Save", M_FILE_SAVE);
fMenuFile->AddEntry("S&ave as...", M_FILE_SAVEAS);
fMenuFile->AddEntry("&Close", -1);

// adding separator
fMenuFile->AddSeparator();

// next group of menu entries
fMenuFile->AddEntry("&Print", M_FILE_PRINT);
fMenuFile->AddEntry("P&rint setup...", M_FILE_PRINTSETUP);
. . .
fMenuFile->AddSeparator();
fMenuFile->AddEntry("E&xit", M_FILE_EXIT);
```

First we create the File menu by creating an object of class `TGPopupMenu` and adding menu entries with `AddEntry` method. Its first parameter is a hot string, the second – a menu ID. The ampersand character (&) denotes shortcut for each menu entry; you can use the letter after it to manage the menu via keyboard. There are three groups of menu entries separated visually by two separators.

You can add a sub-menu by using the method `TGPopupMenu::AddPopup`. Its first parameter is again a string, the second one – a pointer to a `TGPopupMenu` object that will appear as a sub-menu when the menu entry will be selected. The often used visual indicator of a sub-menu is a right-facing arrow to the right of the parent menu item. Generally only one level of cascading menus is recommended and you should be careful in using more.

Next lines show how to create a menu bar with *File*, *Test* and *Help* menus:

```
// menu bar item layout hints
fMenuBarItemLayout = new TGLayoutHints(kLHintsTop | kLHintsLeft,
                                       0, 4, 0, 0);
fMenuBarHelpLayout = new TGLayoutHints(kLHintsTop | kLHintsRight);

// menu bar
fMenuBar = new TGMenuBar(fMain, 100, 20, kHorizontalFrame);

// adding popup menus
fMenuBar->AddPopup("&File", fMenuFile, fMenuBarItemLayout);
fMenuBar->AddPopup("&Test", fMenuTest, fMenuBarItemLayout);
fMenuBar->AddPopup("&Help", fMenuHelp, fMenuBarHelpLayout);
```

Using the method `TGMenuBar::AddPopup` we add three `TGPopupMenu` objects to the menu bar `fMenuBar`. The first parameter is a hot string used by `TGMenuItem` object. When you add a popup menu to the menu bar, a `TGMenuItem` object is created by the menu bar. It is the name of the popup menu. A menu title should have a one-word name that reflects the purpose of all items within the corresponding popup menu. It should also have a defined character as its unique access key. The second parameter is the popup menu we would like to add. The third one is an object of `TGLayoutHints` type that defines how the menu title will be laid out in the menu bar. In our example the *File* and *Test* menus will be laid out to the left of the menu bar with 4 pixels distance in between, the *Help* menu – will be laid out to the right.

The menu classes provide a very flexible menu system: you can enable, disable, add or remove menu items dynamically. The method `HideEntry(menuID)` hides the menu entry (the entry will not be shown in the popup menu). To enable a hidden entry you should call `EnableEntry(menuID)` method. By default all entries are enabled. The method `DisableEntry(menuID)` helps you to disable a menu entry – it will appear in sunken relieve. The `DeleteEntry(menuID)` method will delete the specified entry from the menu.

A few words about the menu design. A menu should be kept consistent and simple. All related items need to be in a popup menu. The cascade menus should be used judiciously. Try to limit them to one, maximum two levels.

There are some rules for naming the menu objects:

- Define unique names within a menu
- Use capitalized one-word names allowing the quick scan of the menu
- Define unique access key for any menu item
- Indicate by ellipsis (...) after the title with no space when a menu item will pop-up a dialog box

The proper kind of graphical menus is a critical point to every application success and depends of three main factors:

- number of presented items in the menu
- how often the menu is used
- how often the menu contents may change

Toolbar

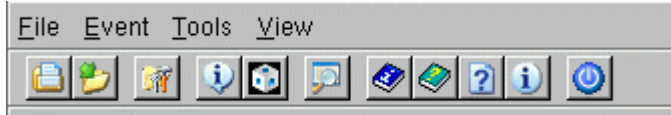

A toolbar (**TGToolBar**) is a composite frame that contains **TGPictureButton** objects. It provides easy and fast access to most frequently used commands or options across multiple application screens. Also, it invokes easily a sub application within an application. All its functions can be obtained by application menus. It is located horizontally at the top of the main window just below the menu bar. All other subtask and sub-feature bars are positioned along sides of window.

```
// toolbar icon files
const char *xpms[] = {
    "x_pic.xpm",
    "y_pic.xpm",
    "z_pic.xpm",
    0
};
// toolbar tool tip text
const char *tips[] = {
    "X Settings",
    "Y Settings",
    "Z Settings",
    0
};
// toolbar button separator
int separator = 5;

// structure containing toolbar button information
ToolBarData_t t[3];

// creation of a toolbar object as a child of main frame
TGToolBar *tb = new TGToolBar(fMain, 520, 80);

for (int i = 0; i < 3; i++) {
    // filling the ToolBarData_t with information
    t[i].fPixmap = xpms[i]; // icon file
    t[i].fTipText = tips[i]; // tool tip text
    t[i].fStayDown = kFALSE; // button behavior if clicked
    t[i].fId = i+1; // button id
    t[i].fButton = NULL; // button pointer

    if (strlen(xpms[i]) == 0) {
        separator = 5;
        continue;
    }
    tb->AddButton(fMain, &t[i], sp);
    separator = 0;
}
// adding the tool bar to the main frame
fMain->AddFrame(tb, new TGLayoutHints(kLHintsTop | kLHintsExpandX));

// adding a horizontal line as a separator
TGHorizontal3DLine *lh = new TGHorizontal3DLine(fMain);
fMain->AddFrame(lh, new TGLayoutHints(kLHintsTop | kLHintsExpandX));
```

To have a tool bar in your application you do not need to do anything special – only to create objects: a tool bar and its picture buttons. This sample code creates the following three toolbar buttons:



First we need to complete a `ToolBarData_t` structure for each tool bar button before adding it to the tool bar. This structure contains:

- the icon file name “`filename.xpm`”
- the tool tip text – a short help message explaining the button purpose
- the Boolean variable defining the button behavior when is clicked
 - `kFALSE` – do not stay down
 - `kTRUE` – to stay down
- the button ID
- the button pointer (`TGButton *`) – should be `NULL`

We create an array `*xpms[]` containing the icon file names that will be used for a picture button creation. If you write only the file names here `ROOT` will search these files in `$ROOTSYS/icons` directory. If the icon files are not there, you should provide the full path name also. The array `*tips[]` contains the tool tip texts for buttons. The integer variable separator is used to set the distance between two groups of toolbar buttons. It defines the amount of pixels to the left for each button.

We create a tool bar object and add the buttons using the `AddButton` method. The variable separator helps us to define no space between the buttons in a group (0), and 5 pixels extra-space before and after. All buttons added via this method will be deleted by the toolbar. On return the `TGButton` field of the `ToolBarData_t` structure is filled in (if the icon pixmap was valid). The first parameter is the window to which the button messages will be sent.

Lastly, we create an object of class `TGHorizontal3DLine` – a horizontal 3D line. It will separate the toolbar from the menu bar because the layout hints we define as `kLHintsTop | kLHintsExpandX`.

It is user friendly to allow the possibility for the tool bar to be turned on or off (via a menu). If you use a single tool bar, it should fill the complete width of its parent. When using more than one, you should also think about setting the bar size to the end of the most right button. This way other bars can be displayed in the same row below the menu bar.

Tool bar buttons should have equal size, meaningful and unique icons, and short meaningful tool tip text. The related buttons should be grouped together by frequency or sequence of use, or importance. Potentially destructive buttons must be separated from them to avoid accidental activation and potentially catastrophic results.

Temporarily not available items should be displayed grayed out.

List Boxes

The purpose of a list box is to display a collection of items from which single or multiple selection can be made. It is always visible, having a scroll bar when the displayed area is not enough to show all items. The choices may be mutually exclusive (a list box with single selection) or not mutually exclusive (a list box with multiple selection).

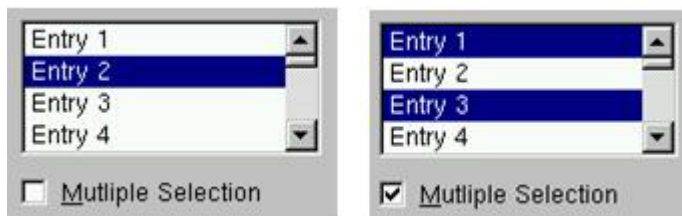

The proper usage of the list boxes is for selecting values, or objects, or setting attributes. You have to create them to display 4 to 8 choices at one time (3 is a required minimum in case of lack of screen space). The list should contain not more than 40 items accessible by scrolling view (vertical scroll bar). If more are required, you should provide a method for using search criteria or scoping the options. The best list boxes use is for textual data or choices. They should be wide enough to display fully all items. When it is not possible, break the long items with ellipsis and provide tool tip that displays the full item text.

The list box widget is represented by **TGListBox**, **TGLBContainer**, **TGLBEntry** and **TGTextLBEEntry** classes.

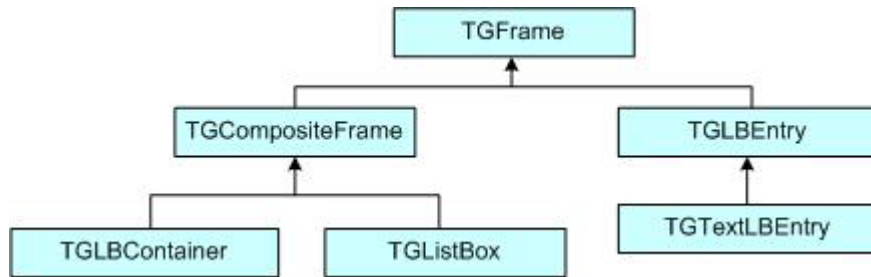

Currently entries are simple text strings (**TGTextLBEEntry**). A **TGListBox** looks a lot like a **TGCanvas**. It has a **TGViewPort** containing a **TGLBContainer** which contains the entries and it also has a vertical scrollbar which becomes visible if there are more items than fit in the visible part of the container. The **TGListBox** is user callable. The other classes are service classes of the list box. Here is a sample code showing how to create a list box with ten entries:

```

// list box widget containing 10 entries
int fFirstEntry = 0;
int fLastEntry = 10;
char tmp[20];

TGListBox *fListBox = new TGListBox(parent, 90);
for (i = fFirstEntry; i < fLastEntry; i++) {
    sprintf(tmp, "Entry %i", i+1);
    fListBox->AddEntry(tmp, i);
}
fListBox->Resize(150, 80);
parent->AddFrame(fListBox,
                new TGLayoutHints(kLHintsTop | kLHintsLeft,5,5,5,5));
  
```

We create the list box widget passing the parent window pointer and giving an ID number. Next we add entries with specified string and ID to the list box. Before adding the list box to its parent widget, it should be resized via `Resize(width, height)` method. The list box width and height are in pixels. The default entry layout hints are `kLHintsExpandX | kLHintsTop`. If you want to add entries using different ones, call the method:

```
TGListBox::AddEntry(TGLBEntry *lbe, TGLayoutHints *lhints);
```

It adds the specified **TGLBEntry** and **TGLayoutHints** to the list box. There are several methods providing a flexible entry manipulation: you can insert, add or remove list box items dynamically. The list box entry IDs are used in these methods and also in event processing routines. In our example the integer variables `fFirstEntry` and `fLastEntry` contain the information about the first and last entry IDs. You can add or remove a list box entry using them in the following way:

```

// adding an entry
fLastEntry++;
sprintf(tmp, "Entry %i", fLastEntry);
fListBox->AddEntry(tmp, fLastEntry);
fListBox->MapSubwindows();
fListBox->Layout();
. . .
// removing an entry
if (fFirstEntry < fLastEntry) {
    fListBox->RemoveEntry(fFirstEntry);
    fListBox->Layout();
    fFirstEntry++;
}
  
```

A single-selection list box is used for selecting only one item in a list.

A multiple-selection list box permits selection of more than one item. The selected choices should be visible – you have several choices to do this:

- to mark selected choices with a check mark or highlight them
- to provide a summary list box to the right of the list box, containing the selected choices
- to provide a display-only text control indicating the number of selected choices (its position should be justified upper-right above the list box)
- if the actions *Select All* or *Deselect All* must be quickly or frequently performed, use command buttons

Combo Boxes

A combo box is a single-selection list box that shows only the currently selected entry and a prompt button displayed as a downward arrow. The prompt button provides a visual cue that a list box is hidden. Its main advantage is consuming of quite a bit of screen space. When the user clicks on it, a list pops up, from which a new choice can be made. After a new item is chosen the combo box folds again showing the new selection.

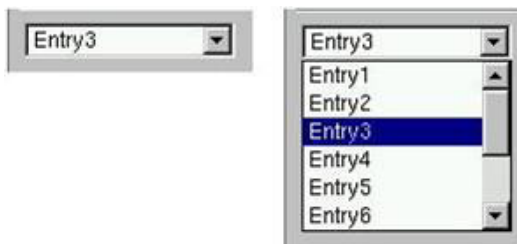

The combo box widget is represented by the user callable class `TGComboBox`. The class `TGComboBoxPopup` is a service class.

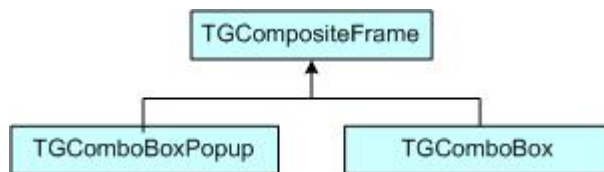

The combo box constructor is very similar to the list box one. The first parameter is a parent widget pointer again, the second – an integer value that will be used as combo box ID. The method used for adding entries is very similar to the list box method we used before. The method `Select(entryID)` sets the current combo box entry.

```
char tmp[20];

// combo box layout hints
fLCombo = new TGLayoutHints(kLHintsTop | kLHintsLeft, 5, 5, 5, 5);

// combo box widget
TGComboBox *fCombo = new TGComboBox(parent, 100);
for (i = 0; i < 10; i++) {
    sprintf(tmp, "Entry%i", i+1);
    fCombo->AddEntry(tmp, i+1);
}
fCombo->Resize(150, 20);

// Entry3 is selected as current
fCombo->Select(2);
parent->AddFrame(fCombo, fLCombo);
```

You have the same flexibility to add, insert or remove entries. As with list boxes you can retrieve the information for currently selected item via `GetSelected` or `GetSelectedEntry` methods. The first one returns the entry ID, the second – the current entry pointer (`TGLBEntry *`).

Sliders

A slider is a scale with an indicator (slider) that you can drag to choose a value from a predefined range. It may be oriented horizontally or vertically. In both cases it provides an excellent indication of where a value exists within a range of values.

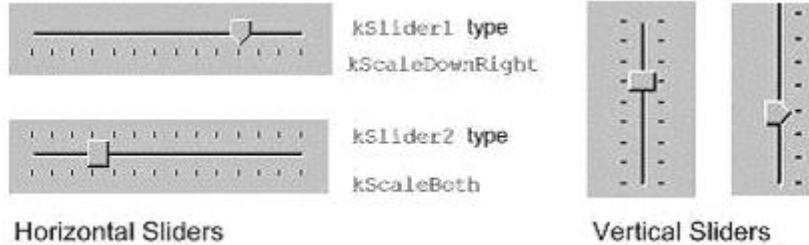

The class **TGHSlider** represents the horizontal slider; **TGVSslider** – the vertical one. Both inherit from the base class **TGSlider** that creates the main slider parameters: the range of values within a value can be selected; the indicator type; the tick mark scale. Using its methods **SetRange**, **SetPosition** and **SetScale** you can set these parameters. To retrieve the set slider value you can call **GetPosition** method.

Next sample code creates a horizontal slider **hslider** with a tick mark of type **kSlider1**. Its width is 150 pixels, and its scale is placed down (**kScaleDownRight**). The last parameter in the **TGHSlider** constructor is the slider ID. It will be used for event processing. The methods **SetRange** and **SetPosition** set the range and the current tick mark position of the slider.

```
hslider = new TGHSlider(parent, 150, kSlider1 | kScaleDownRight, sID);
hslider->SetRange(0, 50);
hslider->SetPosition(39);
```

Slider values can be set by using the mouse to drag the slider across the scale until the desired value is reached. Another way is to click in the slider trough instead of dragging.

Double Slider

Double slider widgets allow easy selection of a min and a max value out of a range. They can be either horizontal or vertical oriented. There is a choice of different types of tick marks: **kDoubleScaleNo**, **kScaleDownRight**, **kDoubleScaleBoth**.

To change the *min* value you should press the left mouse button near to the left (**TGDoubleHSslider**) or bottom (**TGDoubleVSslider**) edge of the slider. Alternatively, to change the *max* value you need to press the mouse near to the right (**TGDoubleHSslider**) or top (**TGDoubleVSslider**) edge of the slider. To change both values simultaneously you should press the left mouse button near to the center of the slider.

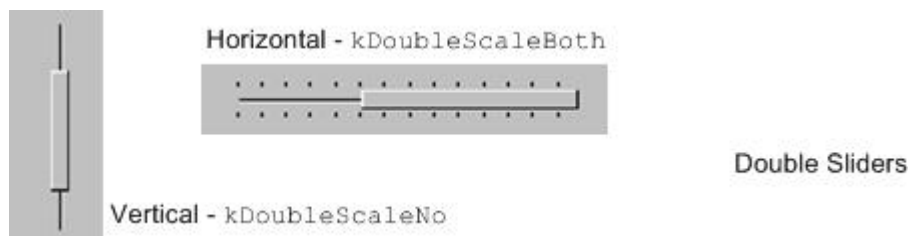

TGDoubleSlider is an abstract base class that creates the main slider parameters. The concrete class to use for a vertical double slider is **TGDoubleVSslider** and **TGDoubleHSslider** for a horizontal one. The double slider constructors are similar to those

of the other sliders. If you set `kDoubleScaleNo` as a scale parameter no scale will be drawn. Here is an example:

```
vDslider = new TGDoubleVSlider(p,100,kDoubleScaleNo,dsliderID);
vDslider->SetRange(-10,10);
```

Progress Bars

A progress bar is a widget that shows that an operation is in progress and how much time is left. It is a long rectangular bar, initially empty, that fills with a color as a process is being performed. The filled-in area indicates the percentage of the process that has been completed. You should use this widget for waits exceeding *one minute*. For a very time consuming operation it is better to break the operation into subtasks and provide a progress bar for each of them.

A progress bar may be oriented horizontally or vertically. The horizontally oriented progress bar fills with a color from left to right; the vertically oriented – from bottom to top. A percent complete message provides an indication of the completed part of the process. It is a good practice to include some descriptive text of the process to keep users informed and entertained while they are waiting for process completion.

The picture below shows the progress bars you can create using the classes **TGProgressBar**, **TGHProgressBar**, and **TGHProgressBar**.



```
// vertical frame with three horizontal progressive bars
TGVerticalFrame *vframe = new TGVerticalFrame(fMain, 10, 10);

fHProg1 = new TGHProgressBar(vframe,TGProgressBar::kStandard,300);
fHProg1->ShowPosition();
fHProg1->SetBarColor("yellow");

fHProg2 = new TGHProgressBar(vframe,TGProgressBar::kFancy,300);
fHProg2->SetBarColor("lightblue");
fHProg2->ShowPosition(kTRUE,kFALSE,"%0.0f events");

fHProg3 = new TGHProgressBar(vframe,TGProgressBar::kStandard,300);
fHProg3->SetFillType(TGProgressBar::kBlockFill);

vframe->AddFrame(fHProg1,new TGLayoutHints(kLHintsTop | kLHintsLeft
                                         | kLHintsExpandX,5,5,5,10));
vframe->AddFrame(fHProg2,new TGLayoutHints(kLHintsTop | kLHintsLeft
                                         | kLHintsExpandX,5,5,5,10));
vframe->AddFrame(fHProg3,new TGLayoutHints(kLHintsTop | kLHintsLeft
                                         | kLHintsExpandX,5,5,5,10));
vframe->Resize(200, 200);
```

Static Widgets

The classes `TGLabel` and `TGIcon` show some information - text or graphics.

The line below creates a label object. The syntax is very simple: you specify the parent widget and a string object holding the desired text.

```
TGLabel *label = new TGLabel(parentWidget, "Label's string");
```

Next sample creates an icon object. First we create an object of type `TGPicture`. The `TGPicture` objects are never created directly by the application code. We call `TGClient` telling it the pixmap's file name to create a `TGPicture` object and, in turn, it will return a pointer to the created object. If the pixmap file cannot be found the returned pointer will be `NULL`. As usual, the first parameter of a `TGIcon` constructor is the parent frame. The second one is the `TGPicture` object holding the pixmap we want to show. Last two parameters define the width and height of pixmap in pixels. In the end we add the created icon object to its parent.

```
// icon widget
const TGPicture *ipic = (TGPicture *)gClient->GetPicture("leaf.xpm");
TGIcon *icon = new TGIcon(parent, ipic, 40, 40);
parent->AddFrame(icon, new TGLayoutHints(kLHintsLeft | kLHintsBottom,
                                       1, 15, 1, 1));
```

The `TGPicture` objects are cached by `TGClient` in order to keep the resource usage low and to improve the efficiency of the client-server windowing systems. `TGClient` will check whether a pixmap with the same name was already loaded before to register a new picture object. If it finds it, it will return a pointer to the existing object. Also, it will increase the usage counter for the object.

All `TGPicture` objects are managed by the class `TGPicturePool`. `TGClient` creates an object of this type upon initialization. Normally your application program does not deal directly with this class because all manipulations go through `TGClient` class.

Once you have finished with using of the `TGPicture` object, you should call the method `TGClient::FreePicture(const TGPicture *pic)` to free it. The usage counter of the picture object will be decreased and when it reaches zero – the `TGPicture` object will be deleted.

Status Bar

The status bar widget is used to display some information about the current application state: what is being viewed in the window, a descriptive message about selected objects, or other non-interactive information. It may also be used to explain highlighted menu and tool bar items.

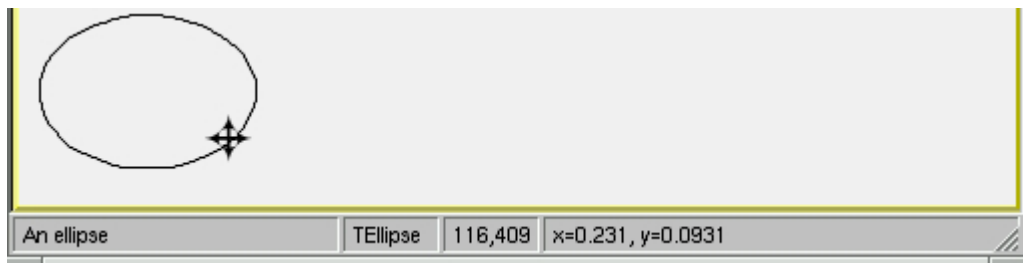

An application can only have one status bar at a time.

There is nothing special to create a status bar in your application. You should decide how many fields you need to present the current application state to the user. By default a status bar consists of one part. Multiple parts can be created by `SetParts` method. Its first parameter is an array of integers that give the percentage size of each part. The second parameter gives the number of status bar parts. Using `SetText` method you can set a text for any part.

```

// status bar
Int_t parts[] = {33, 10, 10, 47};
fSStatusBar = new TGStatusBar(fMain, 50, 10, kHorizontalFrame);
fSbar->SetParts(parts, 4);

fMain->AddFrame(fStatusBar, new TGLayoutHints(kLHintsBottom |
                                             kLHintsLeft | kLHintsExpandX, 0, 0, 2, 0));
. . .
// fill status bar fields with information; selected is the object
// below the cursor; atext contains pixel coordinates info
fStatusBar->SetText(selected->GetTitle(), 0);
fStatusBar->SetText(selected->GetName(), 1);
fStatusBar->SetText(atext, 2);
fStatusBar->SetText(selected->GetObjectInfo(px, py), 3);

```

Splitters

A window can be split into two parts (panes) by using a horizontal or a vertical splitter. A horizontal splitter resizes the frames above and below of it; a vertical splitter resizes the frames left and right of it.

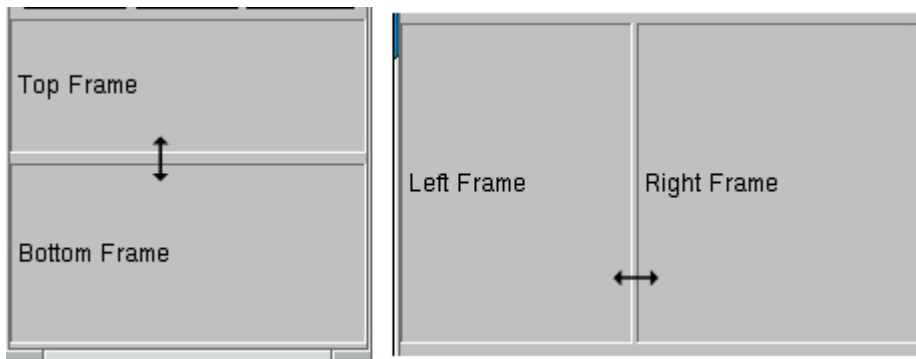

This widget is represented by **TGSSplitter**, **TGHSplitter**, and **TGVSSplitter** classes. Currently there is no special graphics representation for splitter widgets; only the cursor changes when crossing a splitter.

There is nothing special to create a splitter – two lines of code only:

```

TGHSplitter *hsplitter = new TGHSplitter(fVf);
hsplitter->SetFrame(fh1, kTRUE);

```

You call a horizontal **TGHSplitter** or a vertical **TGVSSplitter** splitter constructor and after you set the frame to be resized via `SetFrame` method. In spite of that, there are rules to be followed when you create a splitter in your application.

For a *horizontal* splitter they are:

- the parent of a horizontal splitter must inherit from **TGCompositeFrame** and must have a vertical layout
- the *above* resized frame must have `kFixedHeight` option set
- use layout hints `kLHintsTop | kLHintsExpandX` when adding the *above* resized frame to its parent
- use layout hints `kLHintsBottom | kLHintsExpandX | kLHintsExpandY` when adding the bottom resized frame to its parent
- set the *above* frame to be resized using `SetFrame` method; the second parameter should be `kTRUE`

You can see these rules in the code below:

```
// Create horizontal splitter
fVf = new TGVerticalFrame(fMain,10,10);
fH1 = new TGHorizontalFrame(fVf,10,10, kFixedHeight);
fH2 = new TGHorizontalFrame(fVf,10,10);
fFtop = new TGCompositeFrame(fH1,10,10, kSunkenFrame);
fFbottom = new TGCompositeFrame(fH2,10,10,kSunkenFrame);

fLtop = new TGLLabel(fFtop,"Top Frame");
fLbottom = new TGLLabel(fFbottom,"Bottom Frame");

fFtop->AddFrame(fLtop,
               new TGLayoutHints(kLHintsLeft | kLHintsCenterY,3,0,0,0));
fFbottom->AddFrame(fLbottom,
                  new TGLayoutHints(kLHintsLeft | kLHintsCenterY,3,0,0,0));

fH1->AddFrame(fFtop,new TGLayoutHints(kLHintsTop
                                     | kLHintsExpandY | kLHintsExpandX,0,0,1,2));
fH2->AddFrame(fFbottom,new TGLayoutHints(kLHintsTop
                                         | kLHintsExpandY | kLHintsExpandX,0,0,1,2));

fH1->Resize(fFtop->GetDefaultWidth(),fH1->GetDefaultHeight()+20);
fH2->Resize(fFbottom->GetDefaultWidth(),fH2->GetDefaultHeight()+20);

fVf->AddFrame(fH1, new TGLayoutHints(kLHintsTop | kLHintsExpandX));

TGHSplitter *hsplitter = new TGHSplitter(fVf);
hsplitter->SetFrame(fH1,kTRUE);
fVf->AddFrame(hsplitter,
             new TGLayoutHints(kLHintsTop | kLHintsExpandX));
fVf->AddFrame(fH2,
             new TGLayoutHints(kLHintsBottom | kLHintsExpandX | kLHintsExpandY));
```

For a *vertical* splitter the rules are:

- the parent of a vertical splitter must inherit from **TGCompositeFrame** and must have a horizontal layout
- the *left* resized frame must have **kFixedWidth** option set
- use layout hints **kLHintsLeft | kLHintsExpandY** when adding the *left* resized frame to the parent
- use layout hints **kLHintsRight | kLHintsExpandX | kLHintsExpandY** when adding the right resized frame to the parent
- set the *left* frame to be resized using **SetFrame** method; the second parameter should be **kTRUE**

Next is a sample code for a vertical splitter:

```
// Create vertical splitter
fHf = new TGHorizontalFrame(fMain, 50, 50);

fV1 = new TGVerticalFrame(fHf, 10, 10, kFixedWidth);
fV2 = new TGVerticalFrame(fHf, 10, 10);

fFleft = new TGCompositeFrame(fV1, 10, 10, kSunkenFrame);
fFright = new TGCompositeFrame(fV2, 10, 10, kSunkenFrame);

fLleft = new TGLLabel(fFleft, "Left Frame");
fLright = new TGLLabel(fFright, "Right Frame");

fFleft->AddFrame(fLleft,
                new TGLayoutHints(kLHintsLeft | kLHintsCenterY,3,0,0,0));
fFright->AddFrame(fLright,
                 new TGLayoutHints(kLHintsLeft | kLHintsCenterY,3,0,0,0));
fV1->AddFrame(fFleft,new TGLayoutHints(kLHintsTop
                                       | kLHintsExpandX | kLHintsExpandY,0,0,5,5));
fV2->AddFrame(fFright,new TGLayoutHints(kLHintsTop
                                       | kLHintsExpandX | kLHintsExpandY,0,0,5,5));

fV1->Resize(fFleft->GetDefaultWidth()+20, fV1->GetDefaultHeight());
fV2->Resize(fFright->GetDefaultWidth(), fV1->GetDefaultHeight());

fHf->AddFrame(fV1,new TGLayoutHints(kLHintsLeft | kLHintsExpandY));

splitter = new TGVSplitter(fHf,2,30);
splitter->SetFrame(fV1, kTRUE);

fHf->AddFrame(splitter,
              new TGLayoutHints(kLHintsLeft | kLHintsExpandY));
fHf->AddFrame(fV2,
              new TGLayoutHints(kLHintsRight | kLHintsExpandX | kLHintsExpandY));
```

22 Automatic HTML Documentation

The class descriptions on the ROOT website have been generated automatically by ROOT itself with the `THtml` class. With it, you can automatically generate (and update) a reference guide for your ROOT classes. Please read the `THtml` class description and the paragraph on Coding Conventions.

The following illustrates how to generate an html class description using the `MakeClass` method. In this example class name is `TBRIK`.

```
root[] THtml html; // instanciate a THtml object
root[] html->MakeClass ("TBRIK")
```

How to generate html code for all classes, including an index?

```
root[] html->MakeAll ();
```

This example shows how to convert a script to html, including the generation of a "gif" file produced by the script. First execute the script.

```
root[] .x htmlex.C
```

Invoke the `TSystem` class to execute a shell script. Here we call the "xpick" program to capture the graphics window into a gif file.

```
root[] gSystem->Exec ("xpick html/gif/shapes.gif")
```

Convert this script into html.

```
root[] html->Convert ("htmlex.C", "Auto HTML document generation")
```

For more details see the documentation of the class `THtml`.

23 PROOF: Parallel Processing

Building on the experience gained from the implementation and operation of the PIAF system we have developed the parallel ROOT facility, PROOF. The main problems with PIAF were because its proper parallel operation depended on a cluster of homogenous equally performing and equally loaded machines. Due to PIAF's simplistic portioning of a job in N equal parts, where N is the number of processors, the overall performance was governed by the slowest node. The running of a PIAF cluster was an expensive operation since it required a cluster dedicated solely to PIAF. The cluster could not be used for other types of jobs without destroying the PIAF performance.

In the implementation of PROOF, we made the slave servers the active components that ask the master server for new work whenever they are ready. In the scheme the parallel processing performance is a function of the duration of each small job, packet, and the networking bandwidth and latency. Since the bandwidth and latency of a networked cluster are fixed the main tunable parameter in this scheme is the packet size. If the packet size is too small the parallelism will be destroyed by the communication overhead caused by the many packets sent over the network between the master and the slave servers. If the packet size is too large, the effect of the difference in performance of each node is not evened out sufficiently.

Another very important factor is the location of the data. In most cases, we want to analyze a large number of data files, which are distributed over the different nodes of the cluster. To group these files together we use a chain. A chain provides a single logical view of the many physical files. To optimize performance by preventing huge amounts of data being transferred over the network via NFS or any other means when analyzing a chain, we make sure that each slave server is assigned a packet, which is local to the node. Only when a slave has processed all its local data will it get packets assigned that cause remote access. A packet is a simple data structure of two numbers: begin event and number of events. The master server generates a packet when asked for by a slave server, taking into account the time it took to process the previous packet and which files in the chain are local to the slave server. The master keeps a list of all generated packets per slave, so in case a slave dies during processing, all its packets can be reprocessed by the left over slaves.

24 Threads

A thread is an independent flow of control that operates within the same address space as other independent flows of controls within a process. In most UNIX systems, thread and process characteristics are grouped into a single entity called a process. Sometimes, threads are called "lightweight processes".

Note: This introduction is adapted from the AIX 4.3 Programmer's Manual.

Threads and Processes

In traditional single-threaded process systems, a process has a set of properties. In multi-threaded systems, these properties are divided between processes and threads.

Process Properties

A process in a multi-threaded system is the changeable entity. It must be considered as an execution frame. It has all traditional process attributes, such as:

- Process ID, process group ID, user ID, and group ID
- Environment
- Working directory

A process also provides a common address space and common system resources:

- File descriptors
- Signal actions
- Shared libraries
- Inter-process communication tools (such as message queues, pipes, semaphores, or shared memory)

Thread Properties

A thread is the schedulable entity. It has only those properties that are required to ensure its independent flow of control. These include the following properties:

- Stack
- Scheduling properties (such as policy or priority)
- Set of pending and blocked signals
- Some thread-specific data (TSD)

An example of thread-specific data is the error indicator, `errno`. In multi-threaded systems, `errno` is no longer a global variable, but usually a subroutine returning a thread-specific `errno` value. Some other systems may provide other implementations of `errno`. With respect to ROOT, a thread specific data is for example the `gPad` pointer, which is treated in a different way, whether it is accessed from any thread or the main thread.

Threads within a process must not be considered as a group of processes (even though in Linux each thread receives an own process id, so that it can be scheduled by the kernel scheduler). All threads share the same address space. This means that two pointers having the same value in two threads refer to the same data. Also, if any thread changes one of

the shared system resources, all threads within the process are affected. For example, if a thread closes a file, the file is closed for all threads.

The Initial Thread

When a process is created, one thread is automatically created. This thread is called the initial thread or the main thread. The initial thread executes the main routine in multi-threaded programs.

Note: At the end of this chapter is a glossary of thread specific terms

Implementation of Threads in ROOT

The `TThread` class has been developed to provide a platform independent interface to threads for ROOT.

Installation

For the time being, it is still necessary to compile a threaded version of ROOT to enable some very special treatments of the canvas operations. We hope that this will become the default later.

To compile ROOT, just do (for example on a debian Linux):

```
./configure linuxdeb2 --with-thread=/usr/lib/libpthread.so
gmake depend
gmake
```

This configures and builds ROOT using `/usr/lib/libpthread.so` as the `Pthread` library, and defines `R__THREAD`. This enables the thread specific treatment of `gPad`, and creates `$ROOTSYS/lib/libThread.so`.

Note: The parameter `linuxdeb2` has to be replaced with the appropriate ROOT keyword for your platform.

Classes

TThread

This class implements threads. The platform dependent implementation is in the `TThreadImp` class and its descendant classes (e.g. `TPosixThread`).

TMutex

This class implements mutex locks. A mutex is a mutually exclusive lock. The platform dependent implementation is in the `TMutexImp` class and its descendant classes (e.g. `TPosixMutex`).

TCondition

This class implements a condition variable. Use a condition variable to signal threads. The platform dependent implementation is in the `TConditionImp` class and its descendant classes (e.g. `TPosixCondition`).

TSemaphore

This class implements a counting semaphore. Use a semaphore to synchronize threads. The platform dependent implementation is in the `TMutexImp` and `TConditionImp` classes.

TThread for Pedestrians

To run a thread in ROOT, follow these steps:

Initialization

Add these lines to your `rootlogon.C`:

```
{
...
// The next line may be unnecessary on some platforms
gSystem->Load("/usr/lib/libpthread.so");
gSystem->Load("$ROOTSYS/lib/libThread.so");
...
}
```

This loads the library with the `TThread` class and the `pthread` specific implementation file for `Posix` threads.

Coding

Define a function (e.g. `void* UserFun(void* UserArgs)`) that should run as a thread. The code for the examples is at the web site of the authors (Jörn Adamczewski, Marc Hemberger). After downloading the code from this site, you can follow the example below.

<http://www-linux.gsi.de/~go4/HOWTOthreads/howtothreadsbody.html>

Loading

Start an interactive ROOT session

Load the shared library:

```
root[] gSystem->Load("mhs3.so");
```

Or

```
root[] gSystem->Load("CalcPiThread.so");
```

Creating

Create a thread instance (see also example `RunMhs3.C` or `RunPi.C`) with:

```
root[] TThread *th = new TThread(UserFun, UserArgs);
```

When called from the interpreter, this gives the name "UserFun" to the thread. This name can be used to retrieve the thread later. However, when called from compiled code, this method does not give any name to the thread. So give a name to the thread in compiled use:

```
root[] TThread *th = new TThread("MyThread", UserFun, UserArgs);
```

You can pass arguments to the thread function using the `UserArgs`-pointer. When you want to start a method of a class as a thread, you have to give the pointer to the class instance as `UserArgs`.

Running

```
root[] th->Run();
root[] TThread::Ps(); // like UNIX ps c.ommand;
```

With the `mhs3` example, you should be able to see a canvas with two pads on it. Both pads keep histograms updated and filled by three different threads. With the `CalcPi` example, you should be able to see two threads calculating Pi with the given number of intervals as precision.

TThread in More Detail

CINT is not thread safe yet, and it will block the execution of the threads until it has finished executing.

Asynchronous Actions

Different threads can work simultaneously with the same object. Some actions can be dangerous. For example, when two threads create a histogram object, ROOT allocates memory and puts them to the same collection. If it happens at the same time, the results are undetermined. To avoid this problem, the user has to synchronize these actions with:

```
TThread::Lock() // Locking the following part of code
...           // Create an object, etc...
TThread::Unlock() // Unlocking
```

The code between `Lock()` and `Unlock()` will be performed uninterrupted. No other threads can perform actions or access objects/collections while it is being executed. The `TThread::Lock()` and `TThread::Unlock()` methods internally use a global `TMutex` instance for locking. The user may also define his own `TMutex` `MyMutex` instance and may locally protect his asynchronous actions by calling `MyMutex.Lock()` and `MyMutex.Unlock()`.

Synchronous Actions: TCondition

To synchronize the actions of different threads you can use the `TCondition` class, which provides a signaling mechanism.

The `TCondition` instance must be accessible by all threads that need to use it, i.e. it should be a global object (or a member of the class which owns the threaded methods, see below). To create a `TCondition` object, a `TMutex` instance is required for the `Wait` and `TimedWait` locking methods. One can pass the address of an external mutex to the `TCondition` constructor:

```
TMutex MyMutex;
TCondition MyCondition(&MyMutex);
```

If zero is passed, `TCondition` creates and uses its own internal mutex:

```
TCondition MyCondition(0);
```

You can now use the following methods of synchronization:

- **TCondition::Wait()** waits until any thread sends a signal of the same condition instance: `MyCondition.Wait()` reacts on `MyCondition.Signal()` or `MyCondition.Broadcast()`. `MyOtherCondition.Signal()` has no effect.
- If several threads wait for the signal from the same **TCondition** `MyCondition`, at `MyCondition.Signal()` only one thread will react; to activate a further thread another `MyCondition.Signal()` is required, etc.
- If several threads wait for the signal from the same **TCondition** `MyCondition`, at `MyCondition.Broadcast()` all threads waiting for `MyCondition` are activated at once.

In some tests of `MyCondition` using an internal mutex, `Broadcast()` activated only one thread (probably depending whether `MyCondition` had been signaled before).

- `MyCondition.TimedWait(secs, nanosecs)` waits for `MyCondition` until the *absolute* time in seconds and nanoseconds since beginning of the epoch (January, 1st, 1970) is reached; to use relative timeouts ``delta'', it is required to calculate the absolute time at the beginning of waiting ``now''; for example:

```
Ulong_t now, then, delta;           // seconds
TDateTime myTime;                  // root daytime class
myTime.Set();                       // myTime set to "now"
now=myTime.Convert();              // to seconds since 1970
then=now+delta;                     // absolute timeout
wait=MyCondition.TimedWait(then, 0); // waiting
```

- Return value `wait` of `MyCondition.TimedWait` should be 0, if `MyCondition.Signal()` was received, and should be nonzero, if timeout was reached.

The conditions example shows how three threaded functions are synchronized using **TCondition**: a ROOT script `condstart.C` starts the threads, which are defined in a shared library (`conditions.cxx`, `conditions.h`).

Xlib Connections

Usually `Xlib` is not thread safe. This means that calls to the X could fail, when it receives X-messages from different threads. The actual result depends strongly on which version of `Xlib` has been installed on your system. The only thing we can do here within ROOT is calling a special function `XInitThreads()` (which is part of the `Xlib`), which should (!) prepare the `Xlib` for the usage with threads.

To avoid further problems within ROOT some redefinition of the `gPad` pointer was done (that's the main reason for the recompilation). When a thread creates a `TCanvas`, this object is actually created in the main thread; this should be transparent to the user. Actions on the canvas are controlled via a function, which returns a pointer to either thread specific data (TSD) or the main thread pointer. This mechanism works currently only for `gPad` and will be implemented soon for other global Objects as e.g. `gVirtualX`, `gDirectory`, `gFile`.

Canceling a TThread

Canceling of a thread is a rather dangerous action. In **TThread** canceling is forbidden by default. The user can change this default by calling `TThread::SetCancelOn()`.

There are two cancellation modes:

Deferred

Set by `TThread::SetCancelDeferred()` (default): When the user knows safe places in his code where a thread can be canceled without risk for the rest of the system, he can define these points by invoking `TThread::CancelPoint()`. Then, if a thread is canceled, the cancellation is deferred up to the call of `TThread::CancelPoint()` and then the thread is canceled safely. There are some default cancel points for `pthread`s implementation, e.g. any call of `TCondition::Wait()`, `TCondition::TimedWait()`, `TThread::Join()`.

Asynchronous

Set by `TThread::SetCancelAsynchronous()`: If the user is sure that his application is cancel safe, he could call:

```
TThread::SetCancelAsynchronous();
TThread::SetCancelOn();
// Now cancelation in any point is allowed.
...
// Return to default
TThread::SetCancelOff();
TThread::SetCancelDeferred();
```

To cancel a thread `TThread* th` call:

```
th->Kill();
```

To cancel by thread name:

```
TThread::Kill(name);
```

To cancel a thread by ID:

```
TThread::Kill(tid);
```

To cancel a thread and delete `th` when cancel finished:

```
th->Delete();
```

Deleting of the thread instance by the operator `delete` is dangerous. Use `th->Delete()` instead. C++ `delete` is safe only if thread is not running. Often during the canceling, some clean up actions must be taken. To define clean up functions use:

```
void UserCleanUp(void *arg) {
    // here the user cleanup is done
    ...
}

TThread::CleanUpPush(&UserCleanUp, arg);
    // push user function into cleanup stack "last in, first out"

TThread::CleanUpPop(1); // pop user function out of stack and execute it,
    // thread resumes after this call

TThread::CleanUpPop(0); // pop user function out of stack
    // _without_ executing it
```

Note: `CleanUpPush` and `CleanUpPop` should be used as corresponding pairs like brackets; unlike `pthread`s cleanup stack (which is *not* implemented here), `TThread` does not force this usage.

Finishing thread

When a thread returns from a user function the thread is finished. It also can be finished by `TThread::Exit()`. Then, in case of thread-detached mode, the thread vanishes completely. By default, on finishing `TThread` executes the most recent cleanup function (`CleanUpPop(1)` is called automatically once).

Advanced TThread: Launching a Method in a Thread

Consider a class `Myclass` with a member function

```
void* Myclass::Thread0((void* arg)
```

that shall be launched as a thread. To start `Thread0` as a `TThread`, class `Myclass` may provide a method:

```
int_t Myclass::Threadstart() {
    if(!mTh) {
        mTh= new TThread("memberfunction", (void(*) (void *))&Thread0,
                        (void*) this);

        mTh->Run();
        return 0;
    }
    return 1;
}
```

Here `mTh` is a `TThread*` pointer which is member of `Myclass` and should be initialized to 0 in the constructor. The `TThread` constructor is called as when we used a plain C function above, except for the following two differences.

First, the member function `Thread0` requires an explicit cast to `(void(*) (void *))`. This may cause an annoying but harmless compiler warning:

```
Myclass.cxx:98: warning: converting from
                "void (Myclass::*)(void *)" to "void *" )
```

Strictly speaking, `Thread0` must be a static member function to be called from a thread. Some compilers, for example `gcc` version 2.95.2, may not allow the `(void(*) (void*))s` cast and just stop if `Thread0` is not static. On the other hand, if `Thread0` is static, no compiler warnings are generated at all.

Because the `'this'` pointer is passed in `'arg'` in the call to `Thread0(void *arg)`, you have access to the instance of the class even if `Thread0` is static. Using the `'this'` pointer, non static members can still be read and written from `Thread0`, as long as you have provided Getter and Setter methods for these members.

For example:

```
bool_t state = arg->GetRunStatus();
arg->SetRunStatus(state);
```

Second, the pointer to the current instance of `Myclass`, i.e. `(void*) this`, has to be passed as first argument of the threaded function `Thread0` (C++ member functions internally expect the `this` pointer as first argument to have access to class members of the same instance). `pthreads` are made for simple C functions and do not know about `Thread0` being a member function of a class. Thus, you have to pass this information by hand, if you want to access all members of the `Myclass` instance from the `Thread0` function.

Note: Method `Thread0` cannot be a virtual member function, since the cast of `Thread0` to `void(*)` in the `TThread` constructor may raise problems with C++ virtual function table. However, `Thread0` may call another virtual member function

```
virtual void Myclass::Func0()
```

which then can be overridden in a derived class of `Myclass`. (See example `TMhs3`).

Class `Myclass` may also provide a method to stop the running thread:

```
int_t Myclass::Threadstop() {
    if(mTh) {
        TThread::Delete(mTh);
        delete mTh;
        mTh=0;
        return 0;
    }
    return 1;
}
```

Example `TMhs3`: Class `TThreadframe` (`TThreadframe.h`, `TThreadframe.cxx`) is a simple example of a framework class managing up to four threaded methods. Class `TMhs3` (`TMhs3.h`, `TMhs3.cxx`) inherits from this base class, showing the `mhs3` example 8.1 (`mhs3.h`, `mhs3.cxx`) within a class.

The Makefile of this example builds the shared libraries `libTThreadframe.so` and `libTMhs3.so`. These are either loaded or executed by the ROOT script `TMhs3demo.C`, or are linked against an executable: `TMhs3run.cxx`.

Known Problems

Parts of the ROOT framework, like the interpreter, are not yet thread-safe. Therefore, you should use this package with caution. If you restrict your threads to distinct and 'simple' duties, you will be able to benefit from their use.

The `TThread` class is available on all platforms, which provide a POSIX compliant thread implementation. On Linux, Xavier Leroy's Linux Threads implementation is widely used, but the `TThread` implementation should be usable on all platforms that provide `pthread`.

Linux Xlib on SMP machines is not yet thread-safe. This may cause crashes during threaded graphics operations; this problem is independent of ROOT.

Object instantiation: there is no implicit locking mechanism for memory allocation and global ROOT lists. The user has to explicitly protect his code when using them.

Glossary

The following glossary is adapted from the description of the Rogue Wave Threads.h++ package.

Process

A process is a program that is loaded into memory and prepared for execution. Each process has a private address space. Processes begin with a single thread.

Thread

A thread of control, or more simply, a thread, is a sequence of instructions being executed in a program. A thread has a program counter and a private stack to keep track of local variables and return addresses. A multithreaded process is associated with one or more threads. Threads execute independently. All threads in a given process share the private address space of that process.

Concurrency

Concurrency exists when at least two threads are in progress at the same time. A system with only a single processor can support concurrency by switching execution contexts among multiple threads.

Parallelism

Parallelism arises when at least two threads are executing simultaneously. This requires a system with multiple processors. Parallelism implies concurrency, but not vice-versa.

Reentrant

A function is reentrant if it will behave correctly even if a thread of execution enters the function while one or more threads are already executing within the function. These could be the same thread, in the case of recursion, or different threads, in the case of concurrency.

Thread-specific Data

Thread-specific data (TSD) is also known as thread-local storage (TLS). Normally, any data that has lifetime beyond the local variables on the thread's private stack are shared among all threads within the process. Thread-specific data is a form of static or global data that is maintained on a per-thread basis. That is, each thread gets its own private copy of the data.

Synchronization

Left to their own devices, threads execute independently. Synchronization is the work that must be done when there are, in fact, interdependencies that require some form of communication among threads. Synchronization tools include mutexes, semaphores, condition variables, and other variations on locking.

Critical Section

A critical section is a section of code that accesses a non-sharable resource. To ensure correct code, only one thread at a time may execute in a critical section. In other words, the section is not reentrant.

Mutex

A mutex, or mutual exclusion lock, is a synchronization object with two states locked and unlocked. A mutex is usually used to ensure that only one thread at a time executes some critical section of code. Before entering a critical section, a thread will attempt to lock the mutex, which guards that section. If the mutex is already locked, the thread will block until the mutex is unlocked, at which time it will lock the mutex, execute the critical section, and unlock the mutex upon leaving the critical section.

Semaphore

A semaphore is a synchronization mechanism that starts out initialized to some positive value. A thread may ask to wait on a semaphore in which case the thread blocks until the value of the semaphore is positive. At that time the semaphore count is decremented and the thread continues. When a thread releases semaphore, the semaphore count is incremented. Counting semaphores are useful for coordinating access to a limited pool of some resource.

Readers/Writer Lock

A multiple-reader, single-writer lock is one that allows simultaneous read access by many threads while restricting write access to only one thread at a time. When any thread holds the lock for reading, other threads can also acquire the lock reading. If one thread holds the lock for writing, or is waiting to acquire the lock for writing, other threads must wait to acquire the lock for either reading or writing.

Condition Variable

Use a condition variable in conjunction with a mutex lock to automatically block threads until a particular condition is true.

Multithread Safe Levels

A possible classification scheme to describe thread-safety of libraries:

- All public and protected functions are reentrant. The library provides protection against multiple threads trying to modify static and global data used within a library. The developer must explicitly lock access to objects shared between threads. No other thread can write to a locked object unless it is unlocked. The developer needs to lock local objects. The spirit, if not the letter of this definition, requires the user of the library only to be familiar with the semantic content of the objects in use. Locking access to objects that are being shared due to extra-semantic details of implementation (for example, copy-on-write) should remain the responsibility of the library.
- All public and protected functions are reentrant. The library provides protection against multiple threads trying to modify static and global data used within the library. The preferred way of providing this protection is to use mutex locks. The library also locks an object before writing to it. The developer is not required to explicitly lock or unlock a class object (static, global or local) to perform a single operation on the object. Note that even multithread safe level II hardly relieves the user of the library from the burden of locking.

Deadlock

A thread suffers from deadlock if it is blocked waiting for a condition that will never occur. Typically, this occurs when one thread needs to access a resource that is already locked by another thread, and that other thread is trying to access a resource that has already been locked by the first thread. In this situation, neither thread is able to progress; they are deadlocked.

Multiprocessor

A multiprocessor is a hardware system with multiple processors or multiple, simultaneous execution units.

List of Example Files

Here is a list of the examples that you can find on the thread authors' web site (Jörn Adamczewski, Marc Hemberger) at:

www-linux.gsi.de/~go4/HOWTOthreads/howtothreadsbody.html#tth_sEc8

Example: mhs3

- `Makefile.mhs3`
- `mhs3.h`
- `mhs3LinkDef.h`
- `mhs3.cxx`
- `rootlogon.C`
- `RunMhs3.C`

Example: conditions

- `Makefile.conditions`
- `conditions.h`
- `conditionsLinkDef.h`
- `conditions.cxx`
- `condstart.C`

Example: TMhs3

- `Makefile.TMhs3`
- `TThreadframe.h`
- `TThreadframeLinkDef.h`
- `TThreadframe.cxx`
- `TMhs3.h`
- `TMhs3LinkDef.h`
- `TMhs3.cxx`
- `TMhs3run.cxx`
- `TMhs3demo.C`

Example: CalcPiThread

- `Makefile.CalcPiThread`
- `CalcPiThread.h`
- `CalcPiThreadLinkDef.h`
- `CalcPiThread.cxx`
- `rootlogon.C`
- `RunPi.C`

25 Appendix A: Install and Build ROOT

ROOT Copyright and Licensing Agreement:

This is a reprint of the copyright and licensing agreement of ROOT:

Copyright (C) 1995-2003, René Brun and Fons Rademakers.

All rights reserved.

ROOT Software Terms and Conditions

The authors hereby grant permission to use, copy, and distribute this software and its documentation for any purpose, provided that existing copyright notices are retained in all copies and that this notice is included verbatim in any distributions. Additionally, the authors grant permission to modify this software and its documentation for any purpose, provided that such modifications are not distributed without the explicit consent of the authors and that existing copyright notices are retained in all copies. Users of the software are asked to feed back problems, benefits, and/or suggestions about the software to the ROOT Development Team: rootdev@root.cern.ch Support for this software - fixing of bugs, incorporation of new features - is done on a best effort basis. All bug fixes and enhancements will be made available under the same terms and conditions as the original software.

IN NO EVENT SHALL THE AUTHORS OR DISTRIBUTORS BE LIABLE TO ANY PARTY FOR DIRECT, INDIRECT, SPECIAL, INCIDENTAL, OR CONSEQUENTIAL DAMAGES ARISING OUT OF THE USE OF THIS SOFTWARE, ITS DOCUMENTATION, OR ANY DERIVATIVES THEREOF, EVEN IF THE AUTHORS HAVE BEEN ADVISED OF THE POSSIBILITY OF SUCH DAMAGE.

THE AUTHORS AND DISTRIBUTORS SPECIFICALLY DISCLAIM ANY WARRANTIES, INCLUDING, BUT NOT LIMITED TO, THE IMPLIED WARRANTIES OF MERCHANTABILITY, FITNESS FOR A PARTICULAR PURPOSE, AND NON-INFRINGEMENT. THIS SOFTWARE IS PROVIDED ON AN "AS IS" BASIS, AND THE AUTHORS AND DISTRIBUTORS HAVE NO OBLIGATION TO PROVIDE MAINTENANCE, SUPPORT, UPDATES, ENHANCEMENTS, OR MODIFICATIONS.

Installing ROOT

To install ROOT you will need to go to the ROOT website at:

<http://root.cern.ch/root/Availability.html>

You have a choice to download the binaries or the source. The source is quicker to transfer since it is only 3.4 MB, but you will need to compile and link it. The binaries range from 7.4 MB to 11 MB depending on the target platform.

Choosing a Version

The ROOT developers follow the principle of "release early and release often", however a very large portion of a user base requires a stable product therefore generally three versions of the system is available for download – new, old and pro:

- The **new** version evolves quickly, with weekly or bi-weekly releases. Use this to get access to the latest and greatest, but it may not be stable. By trying out the new version you can help us converge quickly to a stable version that can then become the new pro version. If you are a new user we would advice you to try the new version.
- The **pro** (production) version is a version we feel comfortable with to exposing to a large audience for serious work. The change rate of this version is much lower than for the new version, it is about 3 to 6 months.
- The **old** version is the previous pro version that people might need for some time before switching the new pro version. The old change rate is the same as for pro.

Supported Platforms

For each of the three versions the full source is available for these platforms. Precompiled binaries are also provided for most of them:

- Intel x86 Linux (g++, egcs and KAI/KCC)
- Intel Itanium Linux (g++)
- HP HP-UX 10.x (HP CC and aCC, egcs1.1 C++ compilers)
- IBM AIX 4.1 (xlc compiler and egcs1.2)
- Sun Solaris for SPARC (SUN C++ compiler and egcs)
- Sun Solaris for x86 (SUN C++ compiler)
- Sun Solaris for x86 KAI/KCC
- Compaq Alpha OSF1 (egcs1.2 and DEC/CXX)
- Compaq Alpha Linux (egcs1.2)
- SGI Irix (g++, KAI/KCC and SGI C++ compiler)
- Windows NT and Windows95 (Visual C++ compiler)
- Mac MkLinux and Linux PPC (g++)
- Hitachi HI-UX (egcs)
- LynxOS
- MacOS (CodeWarrior, no graphics)

Installing Precompiled Binaries

The binaries are available for downloading from <http://root.cern.ch/root/Availability.html>

Once downloaded you need to unzip and de-tar the file. For example, if you have downloaded ROOT v2.25 for HP-UX:

```
% gunzip root_v2.25.00.HP-UX.B.10.20.tar.gz
% tar xvf root_v2.25.00.HP-UX.B.10.20.tar
```

This will create the directory root. Before getting started read the file README/README. Also, read the Introduction chapter for an explanation of the directory structure.

Installing the Source

You have a choice to download a compressed (tar ball) file containing the source, or you can login to the source code change control (CVS) system and check out the most recent source. The compressed file is a one time only choice; every time you would like to upgrade you will need to download the entire new version. Choosing the CVS option will allow you to get changes as they are submitted by the developers and you can stay up to date.

Installing and Building the Source from a Compressed File

To install the ROOT source you can download the tar file containing all the source files from the ROOT website. The first thing you should do is to get the latest version as a tar file. Unpack the source tar file, this creates directory 'root':

```
% tar zxvf root_v2.25.xx.source.tar.gz
```

Set `ROOTSYS` to the directory where you want root to be installed:

```
% export ROOTSYS=<path>/root
```

Now type the build commands:

```
% cd root
% ./configure --help
% ./configure <target>
% gmake
% gmake install
```

Add `$ROOTSYS/bin` to `PATH` and `$ROOTSYS/lib` to `LD_LIBRARY_PATH`:

```
% export PATH=$ROOTSYS/bin:$PATH
% export LD_LIBRARY_PATH=$ROOTSYS/lib:$LD_LIBRARY_PATH
```

Try running root:

```
% root
```

It is also possible to setup and build ROOT in a fixed location. Please check README/INSTALL for more a detailed description of this procedure.

Target directory

By default, ROOT will be built in the `$ROOTSYS` directory. In that case the whole system (binaries, sources, tutorials, etc.) will be located under the `$ROOTSYS` directory.

Makefile targets

The `Makefile` is documented in details in the README/BUILDSYSTEM file. It explains the build options and targets.

More Build Options

To build the library providing thread support you need to define either the environment variable `'THREAD=-lpthread'` or the configure flag `'--with-thread=-lpthread'` (it is the default for the `linuxegcs` architecture). [Note: this is only tested on Linux for the time being.] To build the library providing CERN RFIO (remote I/O) support you need to define either the environment variable `'RFIO=<path>/libshift.a'` or the configure flag `'--with-rfio=<path>/libshift.a'`. For pre-built version of `libshift.a` see <ftp://root.cern.ch/root/shift/>

To build the PAW and Geant3 conversion programs `h2root` and `g2root` you need to define either the environment variable `'CERNLIB=<cernlibpath>'` or the configure flag `'--with-cern-libdir=<cernlibpath>'`.

To build the MySQL interface library you need to install MySQL first. Visit <http://www.mysql.com/> for the latest versions.

To build the strong authentication module used by `rootd`, you first have to install the SRP (Secure Remote Password) system. Visit <http://jafar.stanford.edu/srp/index.html>

To use the library you have to define either the environment variable `'SRP=<srpdir>'` or the configure flag `'--with-srp=<srpdir>'`.

To build the event generator interfaces for Pythia and Pythia6, you first have to get the Pythia libraries available from ftp: <ftp://root.cern.ch/root/pythia/>

To use the libraries you have to define either `'PYTHIA=<pythiadir>'` or the configure flag `'--with-pythia=<pythiadir>'`. The same applies for Pythia6.

Installing the Source from CVS

This paragraph describes how to checkout and build ROOT from CVS for UNIX systems. For description of a checkout for other platforms, please see ROOT installation web page: <http://root.cern.ch/root/CVS.html>.

Note: The syntax is for `ba (sh)`, if you use `at (csh)` you have to substitute `export` with `setenv`.

```
% export CVSROOT=:pserver:cvs@root.cern.ch:/user/cvs
% cvs login
% (Logging in to cvs@root.cern.ch)
% CVS password: cvs
% cvs -z3 checkout root
U root/...
U ...
% cd root
% ./configure --help
% ./configure <platform>
% gmake
```

If you are a part of collaboration, you may need to use setup procedures specific to the particular development environment prior to running `gmake`. You only need to run `cvs login` once. It will remember anonymous password in your `$HOME/.cvspass` file. For more install instructions and options, see the file `README/INSTALL`.

CVS for Windows

Although there exists a native version of CVS for Windows, we only support the build process under the Cygwin environment. You must have CVS version 1.10 or newer. The checkout and build procedure is similar to that for UNIX. For detailed install instructions, see the file `REAMDE/INSTALL`.

Converting a tar ball to a working CVS sandbox

You may want to consider downloading the source as a tar ball and converting it to CVS because it is faster to download the tar ball than checking out the entire source with CVS. Our source tar ball contains CVS information. If your tar ball is dated June 1, 2000 or later, it is already set up to talk to our public server (`root.cern.ch`). You just need to download and unpack the tar ball and then run following commands:

```
% cd root
% cvs -z3 update -d -P
% ./configure <platform>
```

Staying up-to-date

To keep your local ROOT source up-to-date with the CVS repository you should regularly run the command:

```
% cvs -z3 update -d -P
```

Setting the Environment Variables

Before you can run ROOT you need to set the environment variable `ROOTSYS` and change your path to include `root/bin` and library path variables to include `root/lib`. Please note: The syntax is for `ba (sh)`, if you are running `t (csh)` you will have to use `setenv` and `set` instead of `export`.

1. Define the variable `$ROOTSYS` to the directory where you unpacked the ROOT:

```
% export ROOTSYS=/root
```

2. Add `ROOTSYS/bin` to your `PATH`:

```
% export PATH=$PATH:$ROOTSYS/bin
```

3. Set the Library Path

On HP-UX, before executing the interactive module, you must set the library path:

```
% export SHLIB_PATH=$SHLIB_PATH:$ROOTSYS/lib
```

On AIX, before executing the interactive module, you must set the library path:

```
% [ -z "$LIBPATH" ] && export LIBPATH=/lib:/usr/lib
% export LIBPATH=$LIBPATH:$ROOTSYS/lib
```

On Linux, Solaris, Alpha OSF and SGI, before executing the interactive module, you must set the library path:

```
% export LD_LIBRARY_PATH=$LD_LIBRARY_PATH:$ROOTSYS/lib
```

On Solaris, in case your `LD_LIBRARY_PATH` is empty, you should set it:

```
% export LD_LIBRARY_PATH=$LD_LIBRARY_PATH:$ROOTSYS/lib:/usr/dt/lib
```

`ROOTSYS` is an environment variable pointing to the ROOT directory. For example, if you use the HPUX-10 AFS version you should set:

```
% export ROOTSYS=/afs/cern.ch/na49/library.4/ROOT/v2.23/hp700_ux102/root
```

To run the program just type: `root`

Documentation to Download

PostScript Documentation

The following PostScript files have been generated by automatically scanning the ROOT HTML files. This documentation includes page numbers, table of contents and an index.

- The latest revision of the Users Guide (5MB, 350 pages):
<http://root.cern.ch/root/RootDoc.html>
- ROOT Overview: Overview of the ROOT system (365 KB, 81 pages)
<ftp://root.cern.ch/root/ROOTMain.ps.gz>
- ROOT Tutorials: The ROOT tutorials with graphics examples (320 KB, 81 pages)
<ftp://root.cern.ch/root/ROOTTutorials.ps.gz>
- ROOT Classes: Description of all the ROOT classes (1.47 MB, 661 pages)
<ftp://root.cern.ch/root/ROOTClasses.ps.gz>

HTML Documentation

In case you only have access to a low-speed connection to CERN, you can get a copy of the complete ROOT html tree (24 MB):

<ftp://root.cern.ch/root/ROOTHtmlDoc.ps.gz>

26 Index

A

accent symbols 118
Accept
 TServerSocket 305, 307
ACLiC 91, 95, 242, 257, 298
Activate (TGFrame) 318
active pad 16, 20, 101, 105, 107, 109, 110, 112, 143
Add
 TBrowser 100
 TChain 244
 TCollection 261
 TFolder 100, 153
 TH1 29
 THStack 45
 TList 170, 265
 TMonitor 307
 TMultiGraph 58
 TObjArray 157
 TTask 155
AddAfter (TList) 265
AddBefore (TList) 265
AddBinContent (TH1) 28
AddButton
 TGToolBar 335
AddDirectory (TH1) 26, 97, 169
AddEntry
 TGComboBox 338
 TListBox 337
 TGPopupMenu 333
 TLegend 145
AddFirst (TList) 265
AddFolder (TFolder) 152, 153
AddFrame
 TGHorizontalFrame 311, 313
 TGMainFrame 311
AddFriend
 TChain 245
 TTree 216, 217
adding a class
 ACLiC 257
 shared library 255
AddLast (TList) 265
AddPopup
 TGMenuBar 334
 TGPopupMenu 334
AddSeparator

TGPopupMenu 333
AddText (TPaveText) 120
Angle (TVector3) 271
AppendPad (TObject) 100, 106
arrow 113, 142
AsSQLString
 TDate 129
asymmetric errors in graphs 56
At
 TList 36
 TObjArray 180, 266
automatic class descriptions 345
automatic schema evolution 185
Autosave (TTree) 201
axis
 alphanumeric bin labels 43
 binning 128
 labels 126
 tick marks 31, 32, 125, 126, 127
 time format 134
 title 33, 103, 124

B

bar
 chart 37
 graph 52
batch mode 11
Begin (TSelector) 242, 297
benchmark 294
Boost
 TLorentzRotation 278
 TVector3 276
branch 201
Branch (TTree) 196, 201, 205
Broadcast (TCondition) 353
Browse (TBranch) 248
browser 82, 158, 171, 293
BypassStreamer (TClonesArray) 177
byte count 202, 256

C

CancelPoint (TThread) 354
canvas 13, 101, 106
 dividing 15, 109
 list of canvases 166
 modified 111

print.....	16
transparent.....	111
update.....	111
updating.....	29
cd	
TCanvas.....	16, 45
TDirectory.....	165
TFile.....	171
TPad.....	16
CenterTitle (TAxis).....	58
chain.....	239, 242, 244, 294, 295, 297, 298, 347
change directory.....	97, 169
ChangeBackground (TGFrame).....	318
ChangeOptions	
TGFrame.....	318, 320
check buttons.....	309
CheckPoint (TGeoManager).....	286
CINT.....	81
commands.....	16
debugger.....	5, 82, 89
dictionary.....	95, 252, 253
library.....	6
class.....	75
class index.....	9
ClassDef.....	104, 173, 185, 250, 252, 255
ClassImp.....	188
ClassName (TObject).....	247
ClassVersionID.....	249
Cleanup	
TGCompositeFrame.....	320
TGMainFrame.....	312
Clear	
TCollection.....	261
TList.....	99
ClearFlags	
TGWidget.....	318
Clicked	
TGButton.....	324
client.....	305
Clone	
TH1F.....	41
TObject.....	248
Close	
TFile.....	170
TPostScript.....	146
TSocket.....	306
coding conventions.....	18, 19
collections.....	259
ordered.....	260
sorted.....	261
unordered.....	261
color.....	140
color palettes.....	140
column-wise ntuples.....	23
combo boxes.....	309
command line.....	16, 82
history.....	21
multi-line command.....	17, 84
quit.....	12
short cuts.....	17
command options.....	11
Compare (TObject).....	262
compression.....	189
Connect	
TQObject.....	324, 326, 327
contact	
mailing list.....	1
context menu.....	14, 103, 104, 108, 122, 135, 138, 139, 142, 143
toggle.....	104
contour.....	30, 31, 35, 36, 37
Convert	
TDate.....	353
THtml.....	345
CosTheta (TVector3).....	270
Cross (TVector3).....	271
curly arc.....	117, 142
curly lines.....	116, 142
current directory....	20, 86, 97, 164, 167, 169, 171, 196, 233, 234
current style.....	148
cursor.....	102
cut.....	225
CVS.....	364
cycle number.....	164
cylindrical coordinates	
TVector3.....	275
D	
debugging.....	89
Delete	
TCollection.....	261
TDirectory.....	172
TList.....	99
TThread.....	354, 356
DeleteEntry	
TGPopupMenu.....	334
DeleteWindow	
TGFrame.....	318
Derivative (TF1).....	13
diamond.....	142
DisableEntry	
TGPopupMenu.....	334
Disconnect	
TQObject.....	327
DistanceToPrimitive (TCanvas).....	105
Divide	
TCanvas.....	15, 16, 45
TH1.....	29
TPad.....	110, 111
documentation.....	366
DoRedraw	
TGFrame.....	318
Dot (TVector3).....	271
Draw	
TArrow.....	77
TBox.....	115
TChain.....	245, 246
TEllipse.....	115
TF1.....	13, 63, 68
TGaxis.....	41
TGraph.....	52
TGraphAsymmErrors.....	57
TH1.....	29, 32, 106, 141
TH2F.....	59

THStack	45
TLine	76
TMarker	54
TMultiGraph	58
TObject	248
TPaveText	120
TProfile	48
TProfile2D	49
TTree	28, 30, 44, 210, 214, 217, 224, 225, 226, 297
draw options for graphs	51
draw options for histograms	30
draw panel	
slider	14
DrawClass (TObject)	247
DrawClone	
TH1	29, 144
TObject	143, 248
DrawClonePad (TCanvas)	143
drawing objects	101
DrawLatex (TLatex)	119
DrawLineNDC (TLine)	109
DrawNormalized (TH1)	29
Dump	
TLine	83
TObject	247

E

E (TLorentzVector)	274
EErrorCode (TInterpreter)	86
ellipse	114, 142
Emit	
TQObject	326
EnableEntry	
TGPopupMenu	334
environment settings	21
errors in graphs	55
Eval (TF1)	13
event list	233
example	7, 289, 290
analysis	297
axis	132, 133
bar graph	52
creating a file	157
creating histogram	290
fitting	67
fitting subranges	65
fitting with user defined function	64
graph	51
graph with continuous line	52
GUI application	295
latex	119, 120
MakeProject	186
mathematical expression	119
physics vector	279
PostScript	147, 148
remote access to a file	191
threads	356, 359
tree read/write	207
tree with a struct	211
tree with an event list	234
tree with Event	219
tree with friends	216

TRef	181
ExecuteEvent	
TArrow	106
TButton	105
TLine	106
exit	12
Exit (TThread)	355
exponential	62

F

Feynman	116
file	
access via web server	192
close	170
compression	189
current directory	165
cycle numbers	164
free block	161
header	159
list of objects	97, 169
objects in memory	165
objects on disk	165
out of scope	170
physical layout	157
read mode	165
record	160
recovery	162
retrieving objects	170
saving collections	169
saving histograms	167
saving objects	169
streamer	173
subdirectories	171
write	167, 170
Fill	
TH1	27, 43
TH2	27
TH3	27
TProfile	46, 48
TProfile2D	49
TTree	200, 207, 211
fill attributes	139
FillRandom (TH1F)	28, 42, 45
FindObject	
TCollection	261
TList	169
TROOT	87
FindObjectAny (TROOT)	153
First (TList)	36
Fit	
TH1	61, 62, 64, 65
TH1F	66
Fit Panel	61
FitSlicesX (TH2)	29
FitSlicesY (TH2)	29
FitSlicesZ (TH3)	29
fitting	<i>See</i> histogram fitting
draw options	62
exponential	62
function	62
gaussian	62
histogram	61

initial parameters.....	63
landau.....	62
options.....	62
polynomial.....	62
predefined function.....	62
quiet.....	62
range.....	62
verbose.....	62
FixParameter (TF1).....	65
folders.....	151
hierarchy.....	152
search.....	153
fonts.....	136
ForceStyle (TROOT).....	30, 149
format characters.....	
date.....	128
time.....	128
fractions.....	117
frame.....	309
frame types.....	319, 320
framework.....	2
components.....	3
organization.....	4
FreePicture.....	
TGClient.....	341
function.....	
derivative.....	13
integral.....	13
number of points.....	13

G

Gaussian.....	28, 42, 61, 62, 157
gDirectory..2, 20, 86, 97, 164, 165, 169, 171, 172, 301, 353.....	
current directory.....	97
deleting objects.....	301
finding objects.....	86, 301
getting objects.....	169, 172, 226, 234
saving current directory.....	176
gEnv.....	19, 21, 138
Get.....	
TDirectory.....	86, 169, 172
TFile.....	42, 64, 123, 162, 210
GetAngleAxis (TRotation).....	273
GetAsymmetry (TH1).....	42
GetBin (TH3).....	27
GetBinCenter (TAxis).....	27
GetBinContent.....	
TH1.....	28
TH1F.....	41
GetBinError (TH1).....	69
GetBranch.....	
TTree.....	214
GetBranch (TTree).....	210
GetChisquare (TF1).....	69
GetClass (TROOT).....	186
GetClassName (TKey).....	163
GetDefaultSize.....	
TGMainFrame.....	312, 316
GetDict (TClassTable).....	221
GetDrawOption (TObject).....	248
GetEntries.....	

TChain.....	245
TTree.....	210
GetEntries (TH1).....	42
GetEntry.....	
TBranch.....	210, 214
TTree.....	209, 210
GetEvent (TChain).....	245
GetExec (TROOT).....	181
GetFile (TDirectory).....	171
GetFrame (TCanvas).....	56
GetFunction (TH1).....	69
GetHistogram (TGraph).....	111
GetLastClick.....	
TGFrame.....	318
GetLinkedLibs (TSystem).....	93
GetList.....	
TDirectory.....	86, 97, 167, 169, 301
GetListOf.. (TROOT).....	20
GetListOfBrowsables.....	
TROOT.....	155
GetListOfBrowsables (TROOT).....	98
GetListOfCanvases (TROOT).....	98
GetListOfCleanUps (TROOT).....	100
GetListOfColors (TROOT).....	140
GetListOfFriends.....	
TChain.....	245
TTree.....	217
GetListOfKeys (TFile).....	162
GetListOfPrimitives (TPad).....	108
GetListOfTasks (TROOT).....	155
GetMaximum.....	
TH1F.....	41
TSlider.....	123
GetMean (TH1).....	42
GetMinimum.....	
TSlider.....	123
GetMinimum (TSlider).....	123
GetName (TKey).....	163
GetNbins (TAxis).....	123
GetObject.....	
TRef.....	181
GetObject (TRef).....	180
GetObjectCount (TProcessID).....	180
GetObjectFit (TMinuit).....	70
GetObjectWithID (TProcessID).....	180
GetOption (TH1).....	32
GetOptions.....	
TGFrame.....	320
GetParameter (TF1).....	69
GetParameters (TF1).....	66
GetParError (TF1).....	69
GetPicture.....	
TGClient.....	341
GetPlot (TMinuit).....	70
GetPosition.....	
TSlider.....	339
GetPrimitive.....	
TPad.....	110, 143
GetPrimitive (TPad).....	107
GetRMS (TH1).....	42
GetRoot.....	
TGClient.....	312
GetRootFolder (TROOT).....	153

GetSeekKey (TKey)	163
GetSelected	
TGComboBox	338
GetSelectedEntry	
TGComboBox	338
GetSender	
TGFrame	318
GetSize	
TCollection	261
TList	36
TObjArray	36
GetState	
TGCompositeFrame	320
GetStreamerInfo	
TClass	183, 187
TH1	183
GetStyle (TROOT)	149
GetTickx (TPad)	32
GetTicky (TPad)	32
GetYmax (TPad)	41
GetWebHistogram (TRef)	181
GetX (TGraph)	54
GetX1 (TLine)	101
GetXaxis	
TGraph	59
TH1	27, 33, 124
TH1F	134
TH2F	123
GetY (TGraph)	54
GetYaxis	
TGraph	59
TH1	33
TH2F	123
gFile	20, 171, 353
gGeoManager	287
gHtml	345
global variables	20
print current settings	22
gRandom	21
graph	51
asymmetric errors	56
axis	52
axis titles	58
bar graph	52
collection	57
draw options	51
errors	55
filling	53
fitting	58
markers	53
superimposing	54
zoom	59
graphical cut	142
graphical editor	142
graphical objects	
adding events	105
coordinate system	
conversion	109
global setting	108
pixel coordinates	109
moving	102
resizing	102
selecting	103

greek font	118, 147
gROOT	20, 93, 100, 140, 141, 166
GUI Application	295

H

H1FitChisquare (TMinuit)	70
H1FitLikelihood (TMinuit)	70
h2root	23, 364
HandleButton	
TGFrame	318
HandleEvent	
TGFrame	318
HandleFocusChange	
TGFrame	318
HandleInput (TCanvas)	105
HandleKey	
TGFrame	318
HandleMotion	
TGFrame	318
HasConnection	
TQObject	327
HasFocus	
TGWidget	318
Hash (TObject)	262
HBOOK	23
heap	77, 86, 87, 170
HideEntry	
TGPopupMenu	334
HideFrame	
TGCompositeFrame	320
HightPriority	
TQObject	326
histogram	25
1-D histograms	25
2-D histograms	25
3-D histograms	25
addition	29
alphanumeric bin labels	43
axis title	33
BAR	37
batch mode	226
change default directory	97, 169
clone	41
color palette	39, 141
contour	35
coordinate systems	36
division	29
draw options	30
drawing	29
draw options	30
setting default	32
refreshing	29
superimpose	29
drawing sub-range	40
error bars	29
filling	27
with random numbers	28
first bin	27
Fit Panel	61
fitting	61, 62
combining functions	67
errors	69

function	62
function list	66
initial parameters	63
options	62
parameter bounds	65
parameters	69
range	65
statistics	69
user defined function	63, 64
last bin	27
legend	144
lego plot	36
list of functions	62
log scale	112
multiplication	29
profile histograms	25
projection	29
reading	42
re-binning	27
automatic re-binning	28
remove from directory	97, 169
saving to file	167
scatter plot	33
second bin	27
second to last bin	27
style	30
sub-range	40
superimpose	40
surface plot	37
variable bin sizes	27
writing	42
history file	21
home directory	165
horizontal splitter	342
I	
I/O redirection	83
icons309	
IgnoreObjectStreamer (TObject)	177, 179, 249
in memory objects	167
include path	93
Inheritance	76, 247
InheritsFrom (TClass)	247
input/output	157
Inspect	
TFile	90
TObject	90, 247
inspecting	90
Inspector (TInspectCanvas)	100
install ROOT	362
Integral	
TF1	13
TH1	42
interpreter	81
Introspection	247
Inverse (TRotation)	273
Invert (TRotation)	273
IsA (TClass)	247
IsBatch (TROOT)	210
IsEnabled	
TGTextButton	318
IsEqual (TObject)	262

IsFolder (TObject)	248
IsSortable (TObject)	262
IsVisible	
TGCompositeFrame	320
iterators	261, 263

J

Join (TThread)	354
----------------	-----

K

kCanDelete	99, 249
kCanRebin (TH1)	28
key	160, 163, 164, 168, 169, 176, 259
Kill (TThread)	354
kMustCleanup	99, 100, 249
KolmogorovTest (TH1)	42
kOverwrite	168

L

label	142
labels	121
LabelsDeflate (TH1)	44
LabelsOption (TH1)	44
landau	62
latex	117, 142
Layout	
TGCompositeFrame	320
layout hints	323
layout managers	309
legends	144
lego plot	36
LegoPlot (TGeoVolume)	287
libraries	6
CINT	6
dependencies	6
license	361
line	113, 142
line attributes	138
LinkDef	8, 175, 254, 255
options	255
list boxes	309
Load	
TSystem	93, 188, 198, 221
Lock (TThread)	352
logarithmic scale	112
Lorentz vector	274
LowPriority	
TQObject	326
ls	
TDirectory	165, 171
TFile	91, 164, 165, 167
TList	166
TNamed	167
TObject	99, 167

M

macro path	22
Mag (TVector3)	270
Mag2 (TVector3)	270

mailing list	1
MakeAll (THtml)	345
MakeClass	237
THtml	345
TTree	224, 237, 241, 297
MakeIterator (TCollection)	261
MakeProject (TFile)	186, 187
MakeSelector (TTree)	224, 297
manual schema evolution	185
Map (TFile)	158, 162
MapSubwindows	
TGMainFrame	312
MapWindow	
TGMainFrame	312
marker	53, 115, 142
mathematical expressions	117
mathematical symbols	118
MatrixMultiplication (TLorentzRotation)	278
memory checker	23
memory leaks	22
menu bars	309
method overriding	76
Minus (TLorentzVector)	277
mkdir (TDirectory)	171
mnplot (TMinuit)	70
Modified (TPad)	111
Move	
TGFrame	318
multi-line command	17
multi-pad canvas	15
multiple sockets	307
Multiply (TH1)	29
mutex	350, 352

N

networking	305
NewPage (TPostScript)	148
Next	
TIter	263
TIterator	262
next (TIter)	265
normalized coordinate system (NDC)	109
Notify (TSelector)	242, 297
ntuple	195
NumberOfConnections	
TOObject	327
NumberOfSignals	
TOObject	327

O

OBJ	164, 166
object	
in memory	165
number	180
on disk	165
ownership	97
Open (TFile)	191, 193
operator() (TIter)	265
operator[] (TObjArray)	266
ordered collections	260
Orthogonal (TVector3)	271

P

pad	
coordinate system	108
copy/paste	143
dividing	109
find an object	107
hide an object	108
modified	111
transparent	111
update	111
updating	29
Paint	
TF1	13
TObject	107, 248
PaintAxis (TGaxis)	128
palette	140
pave	142
PAW	1, 23, 297, 364
Perp (TVector3)	270
Perp2 (TVector3)	270
Phi (TVector3)	270
PhiX (TRotation)	273
PhiY (TRotation)	273
PhiZ (TRotation)	273
physics vector	269
pixel coordinate system	109
PixeltoX (TPad)	109
PixeltoXY (TPad)	109
PixeltoY (TPad)	109
Plus (TLorentzVector)	277
poly-line	114, 142
poly-marker	116
polynomial	62
popup menus	309
PostScript	146
Print	
TEnv	138
TLine	83, 84
TTree	196
print	16
active classes	23
current settings	21
private	76
Process	
TChain	298
TTree	241, 297
Process ID	179
ProcessCut (TSelector)	242, 297
ProcessEvent	
TGFrame	318
ProcessEvents (TSystem)	134
ProcessFill (TSelector)	242, 297
ProcessLine (TROOT)	86, 93
ProcessMessage	
TGFrame	318
profile histograms	46
2D	48
from a tree	48
ProfileX (TH2)	48
ProfileY (TH2)	29, 48
Project (TTree)	236
Project3D (TH3)	29

ProjectionX	
TH2	29
TProfile	29, 48
ProjectionXY (TProfile2D)	29, 48
ProjectionZ (TH3)	29
PROOF	347
PseudoRapidity (TVector3)	270
PutObjectWithID (TProcessID)	180
pwd	
TDirectory	165
TFile	171
Px (TLorentzVector)	274
Py (TLorentzVector)	274
Pz (TLorentzVector)	274

R

radio buttons	309
random numbers	21
RandomPoints (TGeoVolume)	286
RandomRays (TGeoVolume)	286
Range	
TPad	108
TPostScript	146
Rannor	
TRandom	48, 207
Rebin (TH1)	27
Recover (TFile)	162
rectangles	115
Recv (TSocket)	305
RedrawAxis (TPad)	32
Remove	
TCollection	261
TList	108
RemoveEntry	
TGListBox	337
RemoveFrame	
TGCompositeFrame	320
ReOpen (TFile)	193
Reset	
TH1	43
TIter	263
TIterator	262
TROOT	56, 80, 86
ResetBit (TObject)	99
Resize	
TGComboBox	338
TGFrame	318
TGListBox	337
TGMainFrame	312, 316
Rint	165
rootalias.C	22
rootcint	95, 104, 173, 175, 253, 254, 255, 257
help	256
rootd	5, 190, 191, 364
command line arguments	192
rootlogoff.C	22
rootlogon.C	22, 149
rootrc	11, 21, 22, 84, 138
Rotate	
TLorentzRotation	278
TLorentzVector	276
TRotation	273

TVector3	271
RotateAxes (TRotation)	273
RotateUz	
TLorentzVector	276
TVector3	272
RotateX	
TLorentzRotation	278
TLorentzVector	276
TRotation	272
TVector3	271
RotateY	
TLorentzVector	276
TVector3	271
RotateZ	
TLorentzVector	276
TVector3	271
row-wise ntuples	23
RQ_OBJECT	325
RTTI	3, 82, 247, 249, 260
Rtypes.h	250
Run (TThread)	352

S

saving collections to disk	169
Scale (TH1F)	41
scatter plot	33
scope	84, 86, 87, 168, 170, 176
script	84
debugger	89
named	85, 86, 87
path	22
un-named	84, 85, 86, 87
scroll bars	309
Select	
TGComboBox	338
Select (TMonitor)	307
selectors	241
semaphore	351
Send (TSocket)	305
SendMessage	
TGFrame	318
server	305
Set (TDateime)	353
SetAclicMode (TSystem)	92
SetAction (TExec)	181
SetActive (TTask)	156
SetAddress	
TBranch	210, 214
TChain	245
SetArrowSize (TArrow)	77
SetAutoDelete (TTree)	209
SetAutosave (TTree)	201
SetAxisColor (TAxis)	125
SetBarColor	
TGHProgressBar	340
SetBarOffset (TH1)	38
SetBarWidth (TH1)	38
SetBinContent	
TH1	28
TH1F	41, 66, 67, 134
SetBinContent (TH1F)	67
SetBinLabel (Taxis)	43

SetBit (TObject)	28, 99
SetBorderSize (TPaveLabel)	121
SetBranchAddress	
TChain	245
TTree	209, 210
SetCancelAsynchronous (TThread).....	354
SetCancelDeferred (TThread).....	354
SetCancelOn (TThread).....	353
SetCanvasBorderMode (TStyle).....	148
SetCanvasColor (TStyle).....	148
SetColorPalette (TStyle).....	36
SetCommand	
TGWidget	318
SetCompressionLevel (TFile).....	189
SetContour	
TF2.....	141
TH1	31
SetCursor (TPad)	106
SetDirectory	
TH1	97, 169
TTree	97
SetEditable (TPad).....	113
SetEstimate (TTree).....	237
SetEventList (TTree).....	234
SetFCN (TMinuit)	70
SetFillAttributes (TAttFill).....	139
SetFillColor	
TArrow	114
TCanvas	56
TGraph.....	53
TH1F.....	45, 139
TPad.....	21, 123
SetFillColor (TAttFill).....	139
SetFillStyle	
TAttFill	140
TH1F.....	140
TPad.....	111
SetFillType	
TGHProgressBar.....	340
SetFlags	
TGWidget	318
SetFolder (TTree).....	200
SetFrame	
TGHSplitter	343
TGVSplitter	344
SetFrameFillColor (TPad).....	123
SetGraphicsMode (TMinuit)	70
SetGrid	
TCanvas	56, 134
SetHeader (TLegend).....	146
SetHistFillColor (TStyle).....	30
SetHistFillStyle (TStyle)	30
SetHistLineColor (TStyle).....	30
SetHistLineStyle (TStyle).....	30
SetHistLineWidth (TStyle).....	30
SetIncludePath (TSystem)	93
SetIndiceSize (TLatex)	117
SetLabel (TPaveText).....	120
SetLabelColor	
TAxis	125
TGaxis	41
SetLabelFont	
TAxis	125
TStyle.....	149
SetLabelOffset	
TAxis	125
TGaxis.....	131, 132
TStyle.....	149
SetLabelSize	
TAxis	125, 129
TGaxis.....	131, 132, 133
SetLabelSize (TAxis).....	39
SetLayoutManager	
TGCompositeFrame.....	320
SetLimitIndiceSize (TLatex).....	117
SetLineColor	
TAttLine.....	139
TF1	68
TGaxis.....	41
TGraph.....	55
TH1F	41, 134
TLine.....	139
SetLineStyle (TAttLine)	139
SetLineStyleString (TStyle).....	149
SetLineWidth	
TAttLine.....	139
TGraph	55
TLine.....	139
SetLinkedLibs (TSystem)	93
SetLogx (TPad).....	112
SetLogy (TPad).....	112
SetLogz (TPad).....	112
SetMag (TVector3).....	270
SetMarkerColor	
TGraph.....	59
TGraphAsymmErrors.....	57
TGraphErrors	56
TMarker	54
SetMarkerSize	
TMarker	54, 115
SetMarkerStyle	
TGraph.....	54, 55, 59
TGraphAsymmErrors.....	57
TGraphErrors	56
TStyle.....	142
SetMaxDigits (TGaxis)	127
SetMaximum	
TH1F	66, 134
SetMethod (TSlider)	123
SetMinimum (TH1F)	134
SetName	
TGaxis.....	132
TH1F	41
SetNDC (TText)	109
SetNdivisions (TAxis)	125, 134
SetNoExponent	
TAxis	125, 127
TGaxis.....	127
SetNpx (TF1).....	13
SetObject (TRef).....	181
SetObjectCount (TProcessID).....	180
SetObjectFit (TMinuit)	70
SetOptDate (TStyle).....	149
SetOptFit (TStyle).....	69
SetOption (TH1)	32
SetOptStat (TStyle).....	32, 41, 133, 149

SetOwner (TCollection).....	99
SetPadBorderMode (TStyle)	148
SetPadColor (TStyle).....	148
SetPalette (TStyle).....	31, 34, 36, 39, 141, 149
SetPaperSize (TStyle).....	147
SetParameter (TF1).....	65
SetParameters (TF1).....	63, 64, 68
SetParLimits (TF1).....	65
SetParNames (TF1)	64
SetParts	
TGStatusBar	341
SetPasswd (TNetFile).....	190
SetPerp (TVector3).....	270
SetPhi (TVector3).....	270
SetPicture	
TGPictureBox.....	330
SetPosition	
TGHSlider.....	339
TGSlider	339
SetPxPyPzE (TVector3)	275
SetRange	
TAxis	123, 125
TF1.....	14
TGDoubleVSlider.....	340
TGHSlider.....	339
TGSlider	339
SetRangeUser (TAxis).....	125
SetRGB (TColor).....	141
SetRightMargin (TPad)	39
SetScale	
TGSlider	339
SetSize	
TGFrame.....	318
SetStatColor (TStyle).....	148
SetState	
TGCheckBox.....	332
TGRadioButton.....	331
SetStats	
TH1	32
TH1F.....	134
TH2F.....	59
SetStatW (TStyle).....	149
SetStatX (TStyle).....	149
SetStripDecimals (TStyle)	128
SetStyle (TROOT).....	149
SetText	
TGStatusBar	341
SetTextAlign (TLatex).....	119, 135
SetTextAngle (TLatex).....	136
SetTextColor	
TAttText	136
SetTextFont	
TAttText	136
TGaxis	132
SetTextSize	
TAttText	138
TLatex.....	119
SettFillColor	
TPad.....	107
SetTheta (TVector3).....	270
SetTickLength (TAxis).....	125
SetTicks (TPad).....	32
SetTimeDisplay (TAxis).....	128, 129, 134
SetTimeFormat	
TAxis	128, 129
TGaxis.....	131
SetTimeOffset	
TGaxis.....	131
TStyle.....	129
SetTitle	
TAxis	33, 58, 103, 124
TGaxis.....	133
TGraphAsymmErrors.....	57
TGraphErrors	56
SetTitleColor (TStyle)	148
SetTitleH	
TStyle.....	129
SetTitleOffset	
TAxis	125
TGaxis.....	133
TStyle.....	149
SetTitlePos	
TGGroupFrame.....	321
SetTitleSize	
TAxis	125
TGaxis.....	133
SetUser (TNetFile).....	190
SetVect (TVector3).....	275
SetWindowName	
TGMainFrame.....	312
SetWMSize	
TGMainFrame.....	320
SetX (TVector3)	270
SetX1 (TLine).....	83, 84
SetX1NDC (TPaveStats)	32
SetX2NDC (TPaveStats)	32
SetXYZ (TVector3).....	270
SetXYZM (TVector3).....	275
SetXYZT (TVector3).....	275
SetY (TVector3)	270
SetY1 (TLine).....	83, 84
SetZ (TVector3).....	270
Show	
TGButtonGroup	331
Show (TTree).....	224
ShowFrame	
TGCompositeFrame.....	320
ShowPosition	
TGHProgressBar.....	340
ShowStreamerInfo (TFile).....	160, 186
Signal (TCondition)	353
sliders.....	123
socket.....	305
sorted collections	261
special characters	147
spherical coordinates	
TVector3	275
split-level	203
Sqrt (TMath)	67
square root symbol.....	117
stack	77, 86, 87, 122, 170, 356, 357
StartViewer (TTree).....	198, 210
statistics	
fitting.....	69
STL	268
streamer.....	176, 305

Streamer (TObject).....	177, 179, 254
StreamerInfo.....	160, 183
StreamerInfoElement.....	183
streamers.....	173
automatic.....	173
custom.....	175
exclude TObject.....	177
pointers.....	173, 178
prevent splitting.....	175
TClonesArray.....	177
transient data members.....	174
variable length arrays.....	175
writing objects.....	176
style.....	148
subdirectories.....	171
Sumw2 (TH1).....	28, 29, 69
superimposing graphs.....	54
superscripts.....	117
supported platforms.....	4, 362
surface plot.....	37

T

T (TLorentzVector).....	274
tab completion.....	17
TApplication.....	315
TArc.....	116
TArrayC.....	26
TArrayD.....	26
TArrayF.....	26
TArrayS.....	26
TArrow.....	76, 77, 113
tasks.....	154
TAttFill.....	32, 139, 148, 184
SetFillColor.....	139
SetFillStyle.....	140
TAttLine.....	32, 138, 148, 184
SetLineAttributes.....	104
SetLineColor.....	139
SetLineStyle.....	139
SetLineWidth.....	139
TAttMarker.....	32, 116, 148, 184
TAttText.....	32, 135, 148
SetTextAlign.....	135
SetTextAngle.....	136
SetTextColor.....	136
SetTextFont.....	136
SetTextSize.....	138
TAxis.....	27, 44, 124
CenterLabels.....	126
CenterTitle.....	58
SetAxisColor.....	125
SetBinLabel.....	43
SetLabelColor.....	125
SetLabelFont.....	125
SetLabelOffset.....	125
SetLabelSize.....	125, 129
SetNdivisions.....	125
SetNoExponent.....	125, 127
SetRange.....	125
SetRangeUser.....	125
SetTickLength.....	125
SetTimeDisplay.....	128, 129
SetTimeFormat.....	128, 129
SetTitle.....	33, 103
SetTitleOffset.....	125
SetTitleSize.....	125
TBox.....	115
TBranch.....	201, 207, 248
GetEntry.....	210, 214
SetAddress.....	210, 222
SetAutoDelete.....	210
TBranchElement.....	204
TBrowser.....	16, 100, 155, 158, 210, 293
TBtree.....	261
TBuffer.....	176, 185, 254, 256, 257, 305
TCanvas.....	312, 353
cd.....	16, 99, 123, 215, 225
Clear.....	147
Divide.....	15, 99, 148, 215, 224
DrawClonePad.....	143
HandleInput.....	105
ls.....	99
MakeDefCanvas.....	101, 166
Modified.....	134
Range.....	132
SaveAs.....	248
SetBottomMargin.....	302
SetFillColor.....	134, 215
SetFrameFillColor.....	134
SetGrid.....	134, 302
Update.....	111, 134, 147
Write.....	169
TChain.....	98, 239, 240, 244, 298, <i>See</i> chain
AddFriend.....	245
Draw.....	245, 246
GetListOfFriends.....	245
Process.....	298
SetBranchAdress.....	245
SetBranchStatus.....	245
TClass.....	247
GetStreamerInfo.....	183
InheritsFrom.....	247
IsA.....	247
kIgnoreTObjectStreamer.....	249
ReadBuffer.....	174
WriteBuffer.....	174, 177
TClonesArray...177, 204, 205, 206, 209, 219, 220, 223, 242, 243, 260, 267	
BypassStreamer.....	177
TCollection.....	169, 206, 261, 264
Add.....	261
Clear.....	261
Delete.....	261
FindObject.....	261
GetSize.....	261
Remove.....	261
Write.....	169
TColor.....	
SetRGB.....	39, 141
TCondition.....	350, 352, 353
Broadcast.....	353
Signal.....	353
TimedWait.....	353, 354
Wait.....	353
TConditionImp.....	350, 351

TCurlyArc.....	116, 117	SetMaxDigits	127
TCurlyLine	116	SetName.....	132
TCut98, 226, 294		SetNoExponent	127
TCutG	31, 40, 142, 294	SetTextFont.....	132
TDatetime		SetTimeFormat	131
AsSQLString.....	129	SetTimeOffset.....	131
TDirectory	164	SetTitle.....	124, 133
cd	165	SetTitleOffset.....	133
Delete.....	172	SetTitleSize	133
gDirectory.....	171	time axis	131
GetFile	171	TGButton	329, 336
GetList.....	97, 167, 169	Clicked.....	324
ls	165, 166	TGButtonGroup	
mkdir.....	171	Show	331
Write	169, 176	TGCheckBox.....	331
TEllipse.....	115	TGClient	317, 319
template support	250	FreePicture	341
TEnv		GetPicture	341
Print	22	TGCompositeFrame.....	322
Terminate		TGComboBox.....	338
TApplication.....	312, 313	AddEntry.....	338
Terminate (TSelector).....	242, 298	Select.....	338
TestBit (TObject).....	99	TGComboBoxPopup.....	338
TEventList.....	97, 166, 233, 234, 294, 301	TGCompositeFrame.....	320
TExec.....	180, 181	Layout	320
Text (TPostScript)	147	RemoveFrame	320
text attributes	135	SetLayoutManager	320
TF1		TGDoubleHSlider.....	340
Paint.....	13	TGDoubleVSlider	
SetNpx	13	SetRange	340
SetRange.....	14	TGeoChecker	286
TFile	91, 157, 164, 171	TGeoCompositeShape	287
Close.....	170	TGeoManager	285, 286
Get	162	CloseGeometry	287
global scope of.....	170	Export.....	286
Inspect.....	90	Import.....	286
ls	91, 165, 167, 169, 224, 238	TGeoNode.....	285
MakeProject.....	186	TGeoShape.....	284, 287
Map.....	158, 161, 162	TGeoVolume	285, 287
mkdir.....	171	RandomRays	286
Open.....	191, 193	TGFrame.....	318
Recover	162	ChangeOptions.....	319
ReOpen	193	GetOptions	319
SetCompressionLevel	189	options.....	319
ShowStreamerInfo	160, 186	TGFrameElement.....	320
Write	167, 170, 303	TGGroupFrame.....	321
TFile		SetTitlePos	321
pwd	171	TGHButtonGroup	331
TFolder	151, 153	TGHorizontal3DLine.....	335, 336
Add.....	100	TGHorizontalFrame.....	313, 321
AddFolder.....	152, 153	TGHProgressBar	
find.....	154	SetBarColor.....	340
SetOwner	154	SetFillType.....	340
TFormula	63, 225	ShowPosition	340
TFrame	14, 166	TGHSlider.....	339
TFree.....	176, 266	SetPosition	339
TGaxis	124, 126	SetRange	339
Draw	132	TGHSplitter	
PaintAxis.....	128	SetFrame	342
SetLabelColor	41	TGIcon	341
SetLabelOffset.....	132	TGLabel	341
SetLabelSize	131, 132, 133	TGLayotHints.....	322
SetLineColor.....	41	TGLayoutHints	312

hints	323	FillRandom	28
TGLayoutManager	322	Fit	58, 61, 62, 65, 69, 97
TGLBCContainer	337	GetAsymetry	42
TGLBEntry	337	GetAxis	124
TGListBox		GetBinContent	28
AddEntry	337	GetEntries	42
RemoveEntry	337	GetFunction	69
Resize	337	GetMean	42
TGMainFrame	311, 320	GetOption	32
SetWMSize	320	GetRMS	42
TGMatrixLayout	331	Integral	42
TGMenuBar	333	kCanRebin	28
AddPopup	334	KolmogorovTest	42
TGMenuTitle	333, 334	LabelsDeflate	44
TGObject	317, 318	LabelsOption	44
TGPicture	341	Rebin	27
TGPictureButton	329	Reset	43
SetPicture	330	SetBarOffset	38
TGPicturePool	341	SetBarWidth	38
TGPopupMenu		SetBinContent	28
AddEntry	333	SetContour	31, 36
AddPopup	334	SetOption	32
AddSeparator	333	SetStats	32
DeleteEntry	334	Smooth	42
DisableEntry	334	StreamerInfo	184
EnableEntry	334	Sumw2	28, 29, 69
HideEntry	334	UseCurrentStyle	30
TGProgressBar	340	Write	168
TGQt	310	TH1C	25, 28
TGRadioButton	331	TH1D	25, 48, 166, 303
SetState	331	TH1F	25, 26, 28, 41, 64, 66, 67, 86
TGraph	31, 36, 51, 57, <i>See graph</i>	FillRandom	306
draw options	51	SetFillColor	139
GetHistogram	111	SetFillStyle	140
TGraphAsymmErrors	51, 56	TH1S	25, 28
TGraphErrors	51, 55	TH2	
TGSlider		FitSlicesX	29
GetPosition	339	FitSlicesY	29
SetRange	339	ProfileX	29, 48
SetScale	339	ProfileY	29, 48
TGStatusBar		ProjectionX	29
SetParts	342	ProjectionY	29
SetText	342	TH2C	25, 28
TGTextButton	318, 329	TH2D	25, 226, 227
TGToolBar		TH2F	25, 26
AddButton	335	TH2S	25, 28
TGToolTip	330	TH3	
TGTransientFrame	321	FitSlicesZ	29
TGVButtonGroup	331	Project3D	29
TGVerticalFrame	321	ProjectionZ	29
TGVSlider	<i>See TGHSlider</i>	TH3C	25, 28
TGVSplitter		TH3D	25
SetFrame	344	TH3F	25
TGWidget	317	TH3S	25, 28
ClearFlags	318	THashList	44, 260, 262
SetFlags	318	THashTable	261, 262
TGWindow	318	Theta (TVector3)	270
TH1	25, 26, 166	ThetaX (TRotation)	273
AddBinContent	28	ThetaY (TRotation)	273
AddDirectory	26, 97	ThetaZ (TRotation)	273
Draw	29, 62, 106, 141	THistPainter	29
DrawClone	29, 144	thread	349
DrawNormalized	29	threads	356

asynchronous action.....	352	TLorentzVector.....	274
concurrency.....	357	Beta.....	276
deadlock.....	358	Gamma.....	276
lock.....	358	operators.....	275
mutex.....	357	Rotate.....	276
reentrant code.....	357	RotateX.....	276
semaphore.....	357	RotateY.....	276
synchronization.....	357	RotateZ.....	276
THStack.....	45	Vect.....	274
Add.....	45	VectorMultiplication.....	279
Draw.....	45	TMap.....	261, 262
THtml.....	345	TMapIter.....	261
Convert.....	345	TMarker.....	115
MakeAll.....	345	Draw.....	54
MakeClass.....	345	SetMarkerColor.....	54
TimedWait (TCondition).....	353, 354	SetMarkerSize.....	54, 115
TInspectCanvas.....	100	TMatrix.....	281, 290
TIter.....	163, 261, 263, 264, 265, 266	TMatrixColumn.....	281
kIterBackward.....	266	TMatrixFlat.....	281
next.....	265	TMatrixRow.....	281
Next.....	263, 264	TMessage.....	305
Reset.....	263	ReadObject.....	306
TIterator.....	262, 263, 264	WriteObject.....	306
Next.....	262	TMinuit.....	70
Reset.....	262	GetObjectFit.....	70
TKey.....	160, 162, 163, 176	GetPlot.....	70
TLatex.....	33, 117, 121, 135, 142	mplot.....	70
fonts precision.....	136	SetFCN.....	70
mathematical symbols.....	118	SetGraphicsMode.....	70
SetTextFont.....	137	SetObjectFit.....	70
TLeaf.....	201	TMinuitOld.....	70
TLegend.....	144, 146	TMonitor.....	307
AddEntry.....	146	Add.....	307
TLegendEntry.....	144, 145	Select.....	307
TLine.....	75, 113	TMultiDimFit.....	98
ClassDef macro.....	249	TMultiGraph.....	51, 57
ClassImp macro.....	250	Add.....	57
Draw.....	75, 76, 101, 113	TMutex.....	350, 352
DrawLineNDC.....	109	TMutexImp.....	350, 351
Dump.....	83	TNamed.....	42, 107, 159, 184, 226
InheritsFrom.....	247	ls.....	167
method overriding.....	76	TNetFile.....	157, 190, 191, 193
Print.....	83	remote files access.....	191
SetLineColor.....	139	rootd.....	192
SetLineStyle.....	139	SetPasswd.....	190
SetLineWidth.....	139	SetUser.....	190
SetX1.....	83	URL's.....	190
SetY1.....	83	TNtuple.....	195, 294
subclassing.....	76	TObjArray.....	179, 180, 182, 206, 263, 264, 266
TList.....	260, 261	TObjArrayIter.....	263, 264
Add.....	170, 265	TObject.....	7, 19, 41, 89, 107, 153, 247, 260
AddAfter.....	265	AppendPad.....	100, 106
AddBefore.....	265	Clone.....	248
AddFirst.....	265	Compare.....	262
AddLast.....	265	Draw.....	101, 248
After.....	266	DrawClone.....	143, 248
Before.....	266	Dump.....	219
Clear.....	99	fBits.....	99, 177, 249
Delete.....	99	fUniqueID.....	177
iterating over.....	265	Hash.....	262
Write.....	170	inheritance.....	219
TListIter.....	261, 265	Inspect.....	90
TLorentzRotation.....	269, 277, 278, 279	interpreted classes inheritance.....	89

IsEqual	262	AddText	120
IsFolder	248	TPolyLine	114
IsSortable	262	TPolyMarker	116
kCanDelete	99, 249	TPosixCondition	350
kMustCleanup	99	TPosixMutex	350
kOverwrite	216	TPosixThread	350
kSingleKey	169	TPostScript	136, 146, 148
Is	99, 167	Close	148
Paint	107, 248	format options	147
ResetBit	99	NewPage	148
Streamer	177, 179	special characters	147
Streamers	305	Text	147
Write	176, 248	TPrincipal	98
TObject (TestBit)	99	TProcessID	179, 180
TObjLink	265, 266	GetObjectCount	180
toolbar structure ToolBarData_t	335	SetObjectCount	180
ToolBarData_t	336	TProfile	25
TOrdCollection	260	Draw	48
TPad		Fill	46
cd	16, 103, 112	ProjectionX	29, 48
coordinate systems	108, 109	redirected output	236
Draw	112	TProfile2D	25, 226
DrawClone	144	Fill	49
GetListOfPrimitives	108	ProjectionXY	29, 48
GetPrimitive	107, 110, 143, 226	TQObject	325
GetTickx	32	Connect	326
GetTicky	32	Disconnect	327
getting current pad	144	Emit	326
GetUxmax	41	HasConnection	327
GetUymax	41	HighPriority	326
GetUymin	41	LoadRQ_OBJECT	327
Modified	111	LowPriority	326
PaintPadFrame	100	NumberOfConnections	327
PixeltoX	109	NumberOfSignals	327
PixeltoXY	109	TRandom	
PixeltoY	109	Gaus	41, 134, 222
Print	146	Rannor	48, 207
Range	108, 109	Rndm	207
RedrawAxis	32	Transform	
SetCursor	106	TLorentzVector	276
SetEditable	113	TRotation	271
SetFillColor	20, 107, 215	TVector3	274
SetFillStyle	112	transient data members	174
SetLogx	112	treads	
SetLogz	112	initialization	351
SetRightMargin	39	installation	350
SetTicks	32	trees	
Update	29, 227	Autosave	201
UtoPixel	109	branches	201
VtoPixel	109	array of objects	205
WaitPrimitive	112	array of variables	202
x3d	215	identical names	205
XtoPixel	109	list of variables	201
XYtoPixel	109	objects	202
YtoPixel	109	split-level	203
TPaletteAxis	39	creating	200
TPave	140, 145	creating a profile histogram	236
TPaveLabel	121, 122	creating histograms	235
SetBorderSize	121	cut	225
TPaves	121	draw	224
TPaveStats	32, 166	draw options	226
TPavesText	122	profiles	48
TPaveText	14, 104, 122, 140, 142	event list	233

folders	200	changing histogram's style	30
friends	216	constructor	148
histogram style	225, 235	current style	148
MakeClass	237, 238, 241, 242, 297	define parameters in rootlogon.C	149
selection	225	font	35
selectors	241	forcing the current style	149
Show	197	getting the current style	149
static class members	203	SetCanvasBorderMode	148
tree viewer	198	SetCanvasColor	148
TRef	178, 179, 180, 181	SetLabelFont	149
action	180	SetLineStyleString	149
GetObject	180, 181	SetOptDate	149
SetObject	181	SetOptFit	69
TRefArray	181, 182	SetOptStat	149
TROOT		SetPadBorderMode	148
cd	165	SetPadColor	148
collections	20, 98	SetPalette	31, 34, 36, 39, 141, 149
fCleanups	100	SetStatColor	148
finding object	36	SetStripDecimals	128
FindObject	87, 91	setting a style	149
FindObjectAny	153, 154	SetTitleColor	148
ForceStyle	30, 149	SetTitleOffset	149
GetClass	186	TSystem	
GetColor	141	AccessPathName	86
GetExec	181	Exec	148, 345
GetFunction	301	GetLinkedLibs	93
GetListOf... methods	20, 98	Load	188, 198, 351
GetListOfColors	140	ProcessEvent	134
GetRootFolder	153	SetAclicMode	92
GetStyle	149	SetIncludePath	93
gROOT	20, 97	SetLinkedLibs	93
IsBatch	210	TTask	154, 156
Macro	257	Exec	154, 156
ProcessLine	86, 93, 155	ExecuteTask	156
Reset	55, 86, 87	ExecuteTasks	156
SetStyle	149	SetActive	156
Time	298	TText	117, 135
TRootEmbeddedCanvas	312	SetNDC	109
TRotation	269, 272, 273, 277	TThread	350, 351, 356
Inverse	273	CancelPoint	354
Invert	273	CleanUpPop	354
Transform	271	CleanUpPush	354
true type fonts	138	Delete	354
TSelector	242, 297, 298	Exit	355
Begin	242, 297	Join	354
Notify	242, 297	Kill	354
ProcessCut	242, 297	Lock	352
ProcessFill	242, 297	Ps	352
Terminate	242, 297, 298	Run	352
TSemaphore	351	SetCancelAsynchronous	354
TServerSocket	305, 307	SetCancelDeferred	354
TSlider	123	SetCancelOff	354
GetMaximum	123	SetCancelOn	353
GetMinimum	123	Unlock	352
SetMethod	123	TThreadframe	356
TSocket	305, 307	TThreadImp	350
Recv	307	TTimer	326
Select	307	TTree	6, 195, 200
Send	305	AddFriend	216, 246
TSortedList	163, 261	Branch	196, 201, 203, 207, 218
TStreamerElement	180	Draw	28, 30, 44, 48, 210, 211, 214, 217, 224, 225, 227, 233, 297
TStreamerInfo	160	Fill	200, 207, 211
TStyle	30, 148		

GetBranch	222
GetEntries	237
GetEntry	209
GetListOfFriends	217
GetV1	236
GetV2	236
GetV3	236
GetW	236
MakeClass	224, 237, 238, 297
MakeSelector	224, 241, 297, 300
Print	197, 238
Process	241, 242, 297
Project	236
Scan	197
SetAutosave	201
SetBranchAddress	209
SetEstimate	237
SetFolder	200
SetSelectedRows	236
Show	197
StartViewer	198
tree viewer	198
UseCurrentStyle	30, 225, 235
Write	217
TTreeView	198, 297
tutorials	7
TUUIID	179
TVector3	269, 270, 271, 273, 275
TViewerX3D	287
TVirtualX	310, 319
GetWindowID	319
InitWindow	319
TWbox	115, 140
TWebFile	157, 191, 192, 193
types	19

U

UnCheckedAt (TObjArray)	266
Unit (TVector3)	271
UnLock (TThread)	352
unordered collections	261
Update	
TCanvas	111
TPad	29
UseCurrentStyle	
TH1	30
TTree	30, 225, 235
user coordinate system	108
UtoPixel (TPad)	109

V

variable length array	175
Vect (TLorentzVector)	274
VectorMultiplication (TLorentzVector)	279
vertical splitter	343
VtoPixel (TPad)	109

W

Wait (TCondition)	353, 354
WaitPrimitive	
TPad	112
WantFocus	
TGWidget	318
web server	192
web site	9
widgets	309, 317
Write	
TCollection	169
TDirectory	169, 176
TFile	42, 167
TH1F	42
TList	169
TObjArray	157
TObject	176, 248
TTree	207, 216
WriteBuffer (TClass)	177
WriteVersion (TBuffer)	185

X

X (TLorentzVector)	274
x3d (TPad)	215
Xclass'95	309
XtoPixel (TPad)	109
XYtoPixel (TPad)	109

Y

Y (TLorentzVector)	274
YtoPixel (TPad)	109

Z

Z (TLorentzVector)	274
zoom	13, 14, 59